

NILUS II 8 SHAFTS JACK-TYPE LOOM WITH BACK HINGE TREADLES

	8 SHAFTS
36"	1029-3628
45"	1030-4528
60"	1031-6028



On receiving the loom, unpack and lay out the loom components. Do NOT discard any packing material until all parts are inventoried.

Check the parts received against the parts list on pages #2 to #7 of the assembly instructions. Report any discrepancies to Leclerc immediately.

To assemble this loom, a minimum of 2 people are needed but it is recommended you use 3.

Leclerc Looms



Since 1876

1972 Avenue Simoneau
C. P. 4
Plessisville, Qc.
G6L 2Y6

TEL: 819-362-7207
FAX: 819-362-2045
leclerc@leclerclooms.com
www.leclerclooms.com

PARTS LIST

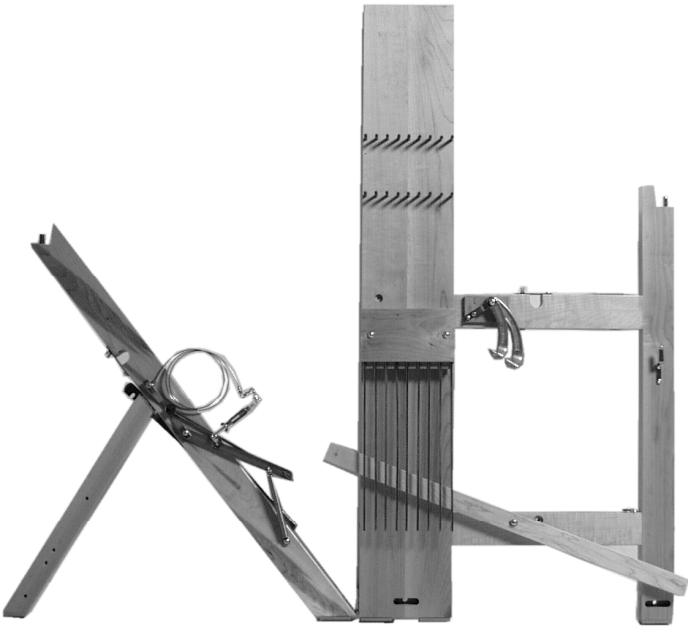

1 left-hand side

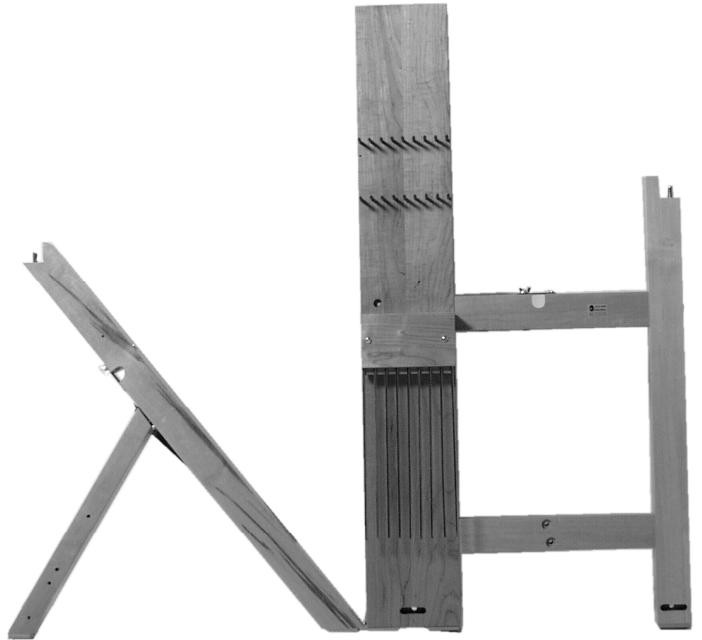

1 right-hand side

*Note for Leclerc in French : Faire les
petit trous dans les montants pour les
baguettes d'encroix.
Mettre les bloc de boîte à
marmoussets.*

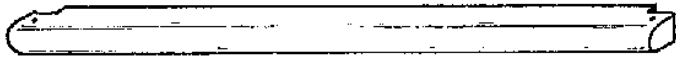

2 breast beams

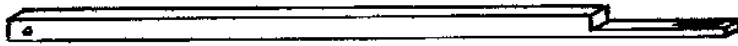

1 left sword



1 right sword

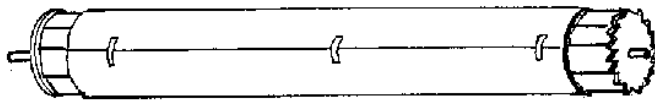

1 cloth (front) beam

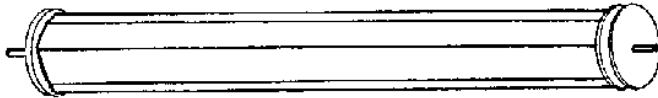

1 warp (back) beam

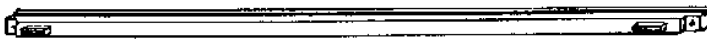

1 batten handtree

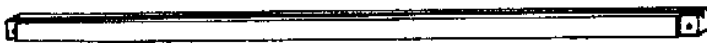

1 batten sley with shuttle race

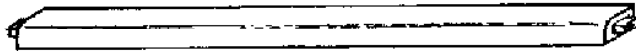

No holes across

1 Front cross-member

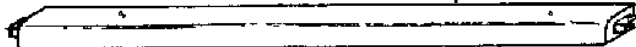

2 small holes in the top

1 Middle set cross-member

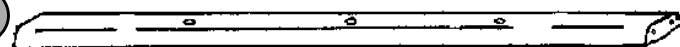

3 holes for treadle set

1 Back cross-member connecting stabilizing posts

26 1/2" CC

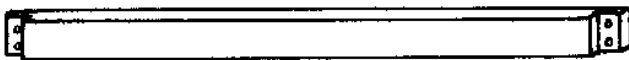

1 cross-board connecting the stabilizing posts



1 apron



1 cloth take-up motion handle

PARTS LIST

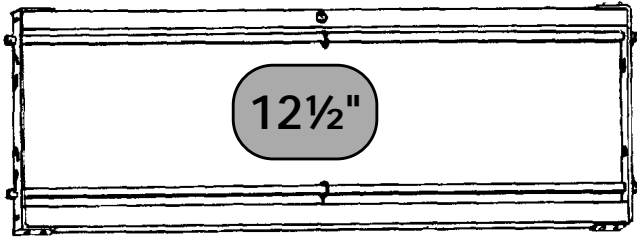

8 shafts

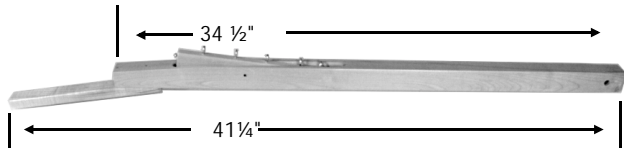

10 treadles with extension

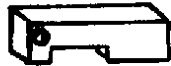

3 treadle supports



1 treadle set rod 28 3/4" with one pushnut

1 more Treadle set
Pushnut

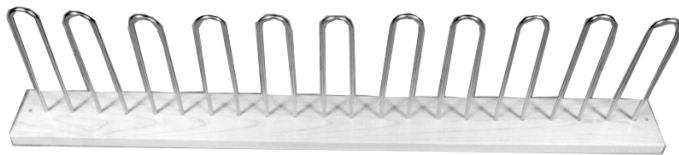

1 treadle separator

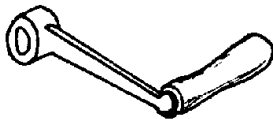

1 Crank

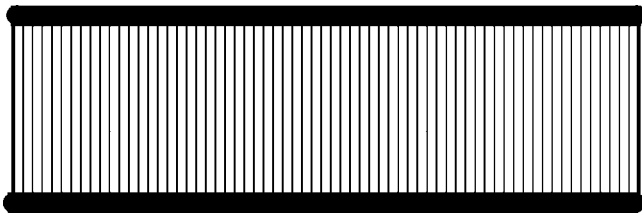

1 reed



2 lease sticks



4 warp rods

PARTS LIST (back-hinge treadle)



3 screwdrivers (Black, Red and Green)



1 aluminum wrench



1 adjustable wrench

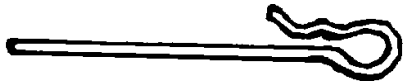

1 set of 10 treadle hooks 10" # 3500-4521



5 sets of 12 treadle cords 7" #3000-7011



1 boat shuttle



12 plastic bobbins



1 threading hook



2 pkg of cords (5 yds each)



12½"

1000 heddles (36" loom)

1200 heddles (45" loom)

1500 heddles (60" loom)

PARTS LIST

8 FLOATING LAMS

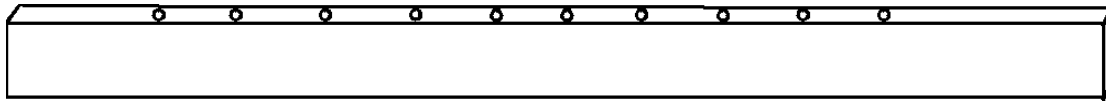

36" = 39 3/4"
 45" = 48 13/16"
 60" = 63 3/4"

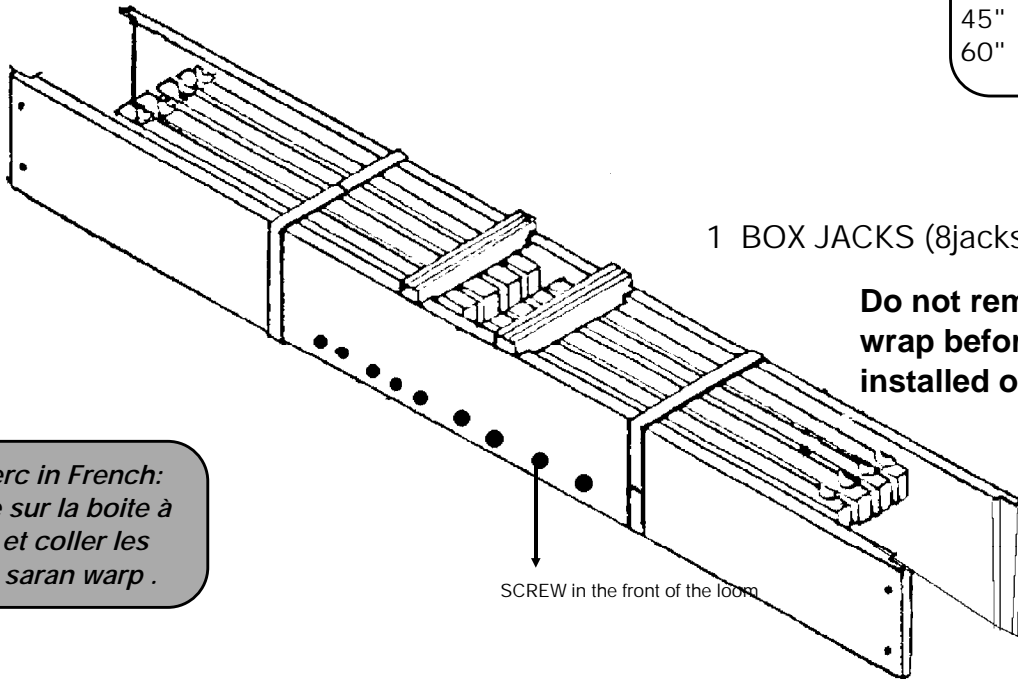

1 BOX JACKS (8jacks)

Do not remove saran wrap before the unit is installed on the loom.

SCREW in the front of the loom

*Note for Leclerc in French:
 Installer la tige sur la boîte à
 marmouset et coller les
 ressorts avec saran warp .*

NOTE: The springs and the rod is
 warp with the jack box



10 springs with 6 1/2" loop cord
 (9 1/2" overall)
 1 Metal rod for spring kit

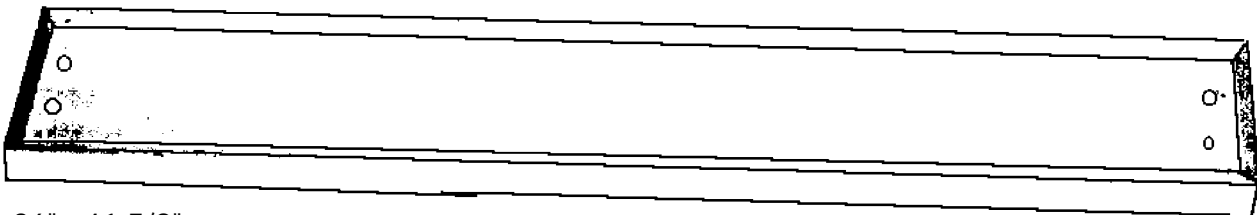

36" = 41 5/8"
 45" = 50 3/4"
 60" = 65 15/16"

1 CASTLE TOP

PARTS LIST(back hinge treadle)

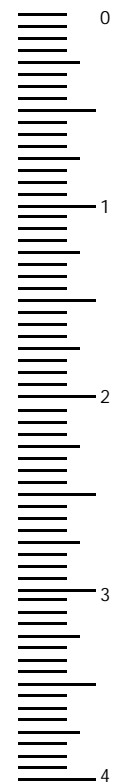

Machine bolts

4X - 3/8" x 5"

Carriage Bolts

4X - 1/4" x 2 1/4"
 4X - 5/16" x 2 1/2" (back hooks)
 3X - 5/16" x 4"
 2X - 5/16" x 3 1/2"

Washers

4X - 3/8"
 11X - 5/16"
 4X - 9/16" (treadle set)

HEXAGON NUTS

2X- Nylon auto lock 5/16"

Wooden spacer

1 1/2"

4X for a 4 shaft loom
 8X for a 8 shaft loom

Square nuts

4X - 3/8"
 5X 5/16"

Round head screw

4X - #12 x 1 1/2"
 8X - #12 x 1 1/2" (jack box)
 4X - #14 x 2 1/2" (treadle set)
 2X - #8 x 1 1/2" (Treadle separator)

Wing nuts

4 X - 1/4" (6 mm)
 5X - 5/16" (8 mm)

Flat head screw

4X - #12 X 1 1/2" (38 mm)
 (castle top)

2X eye screws



1 VHS instruction Video showing all stages of installation.



10 Loop cords 18 1/2" long for treadle rocker

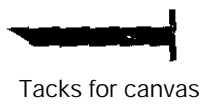

Tacks for canvas

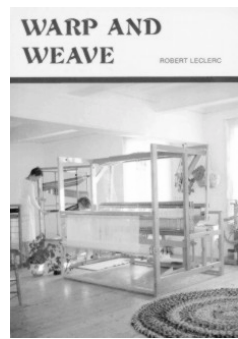

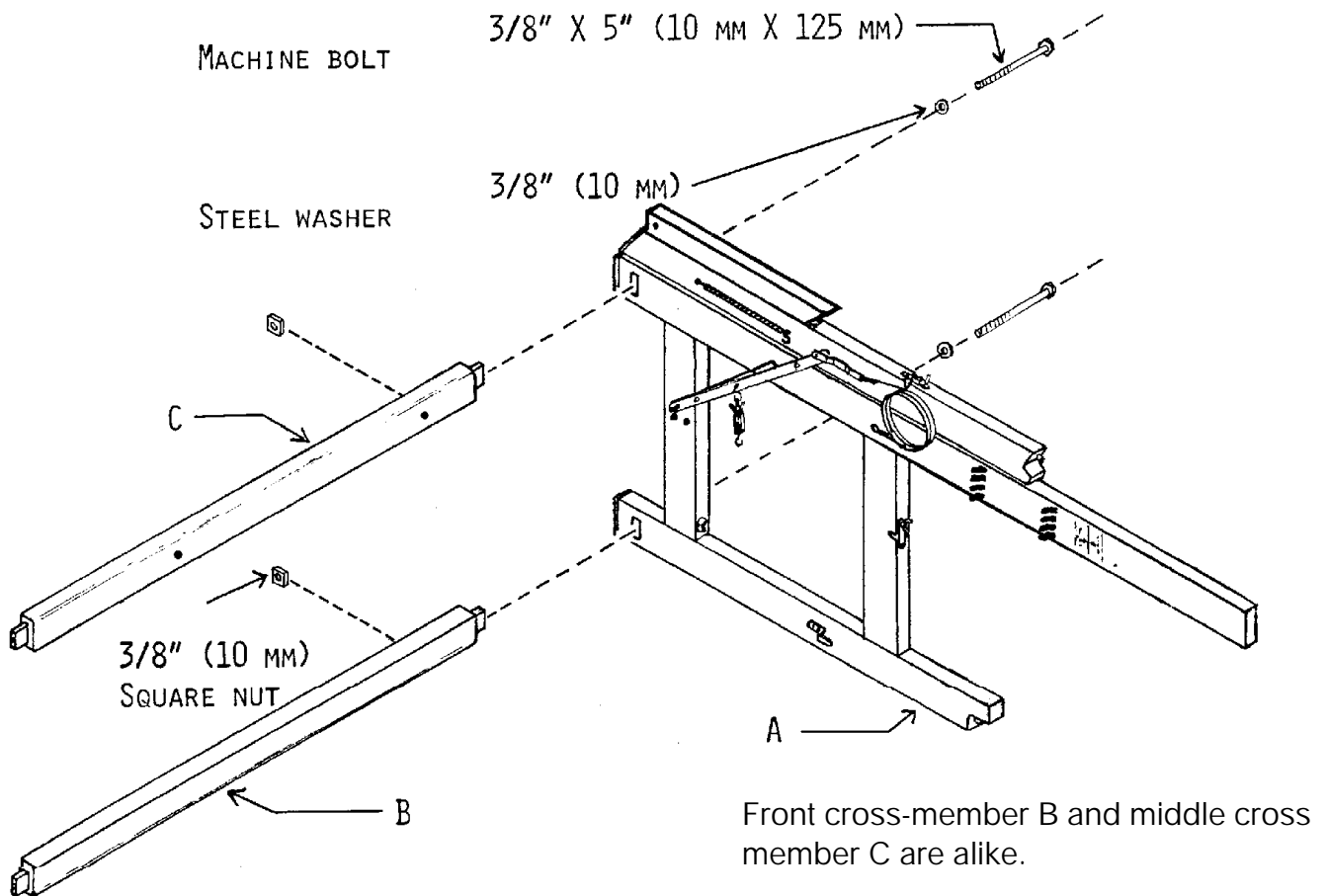

Fig. 1

Place right-hand side A of the loom on its front.

Insert a tenon of lower front cross-member B into the lower front mortise of right-hand side A. (Fig. 1)

NOTE: The lower front cross-member B does not have holes drilled through it

Using the wrench supplied with the loom, affix cross-member B with a 3/8" X 5" (10 mm X 125 mm) machine bolt, a 3/8" (10 mm) steel washer, and a square nut. (Fig. 1)

Insert a tenon of lower back cross-member C into the lower back mortise of right-hand side A. (Fig. 1)

NOTE: The lower back cross-member C does not have 2 small holes drilled through it.

Affix cross-member C with a 3/8" X 5" (10 mm X 125 mm) machine bolt, a 3/8" (10 mm) steel washer, and a square nut (Fig. 1)

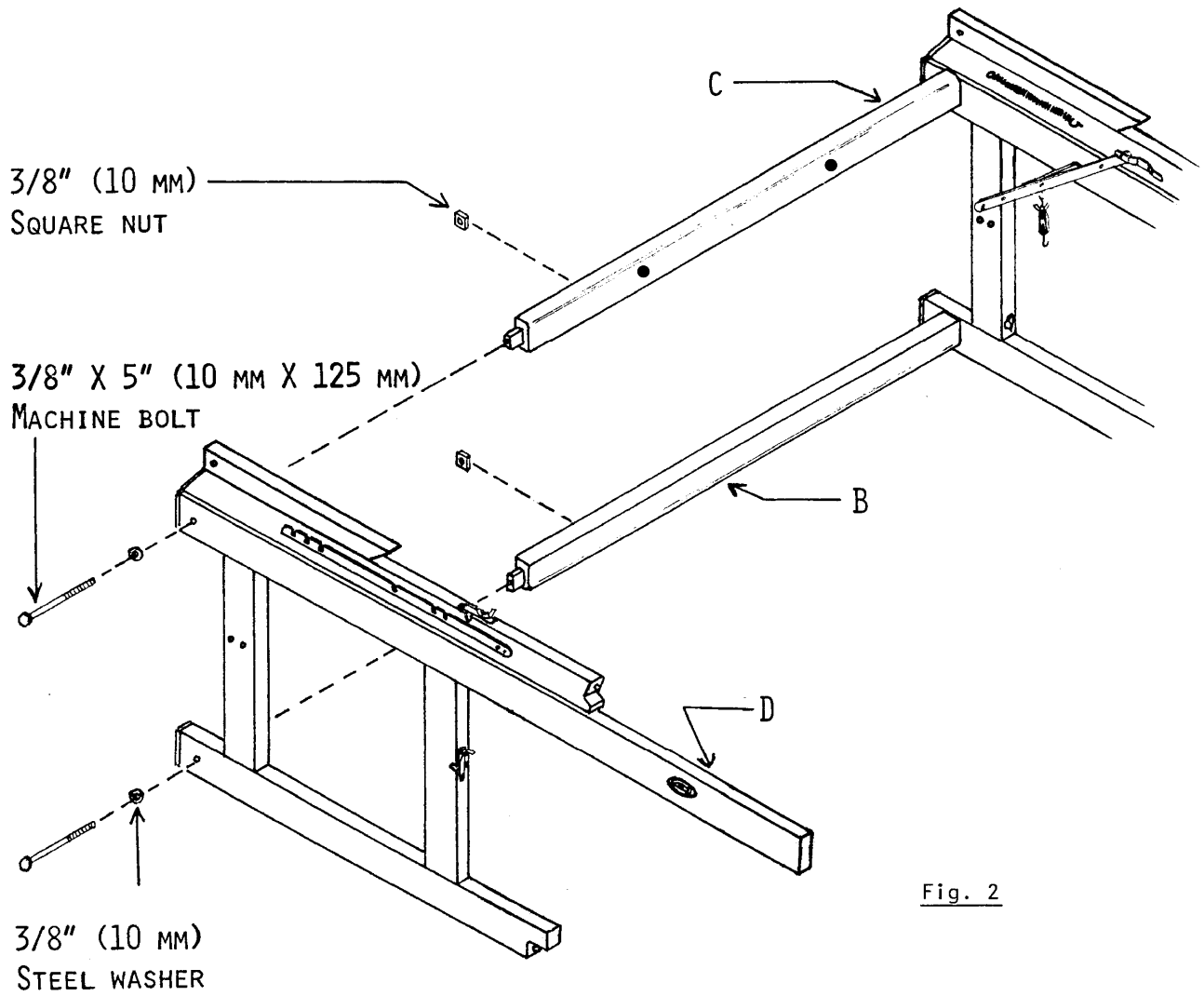

After having placed left-hand side D of the loom on its front, insert the tenons of cross-members B and C into the lower mortises of left-hand side D. (Fig. 2)

Use 3/8" X 5" (10 mm X 125 mm) machine bolts, 3/8" (10 mm) steel washers, and square nuts. (Fig. 2)

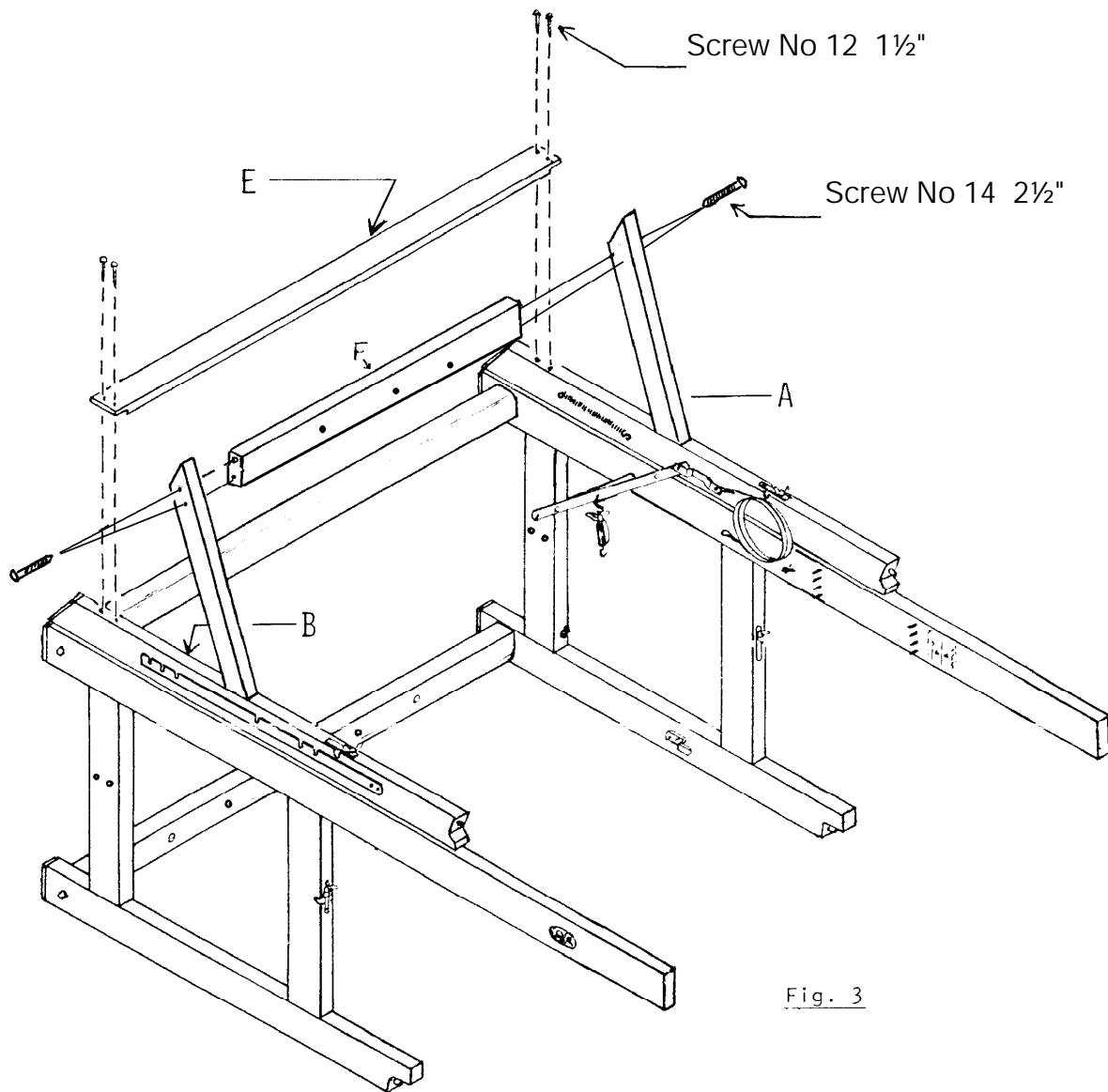

Fig. 3

Using four 1½" (40 mm) round-headed screws No 12, affix back cross-member E to back posts A and B. (Fig. 3)

Using four, 2½" round-headed screws No. 14, affix the treadle cross-member F.

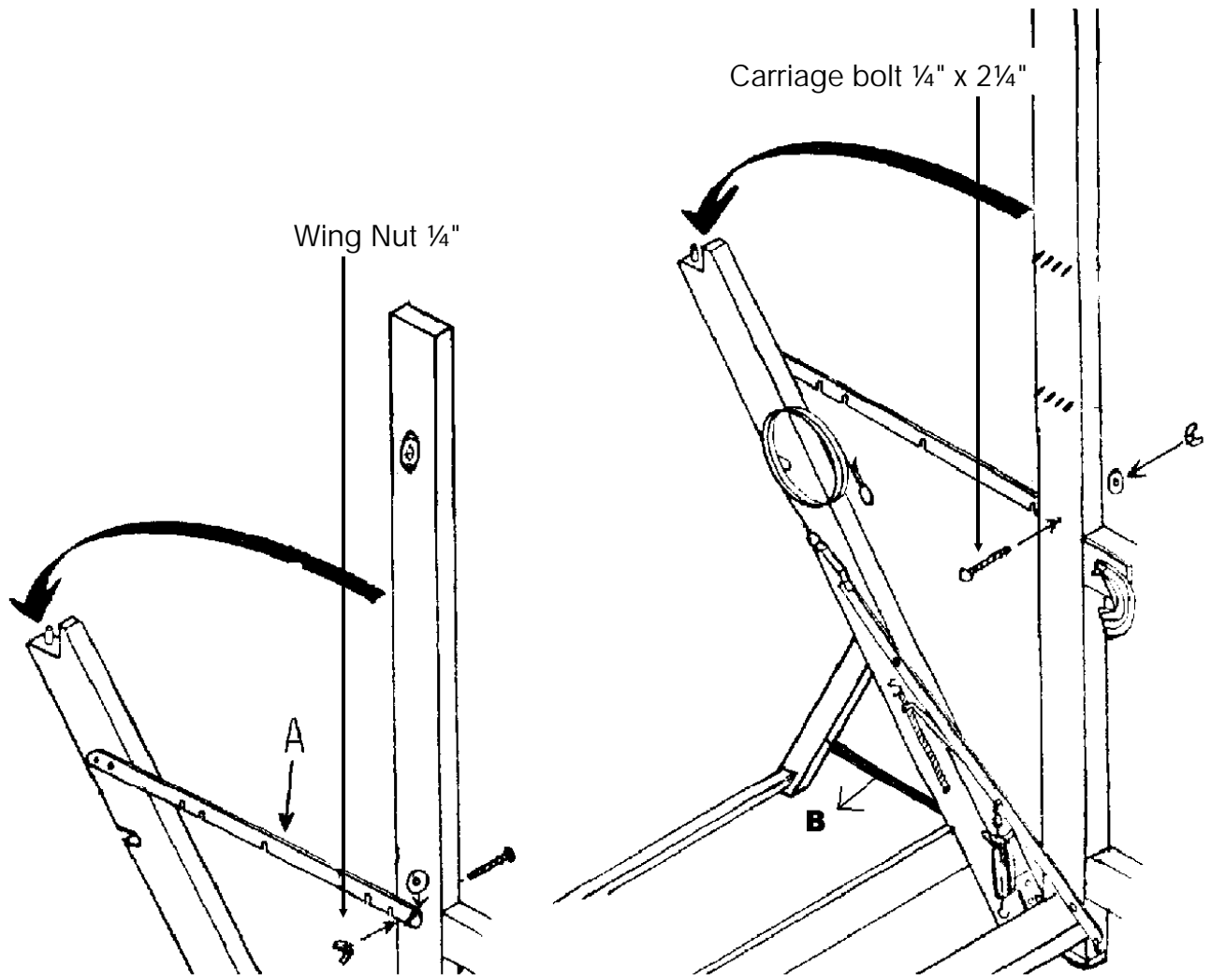

Fig. 4

Place the loom right side up.
 Unfold the back section of the loom.

Insert a $\frac{1}{4}$ " x $2\frac{1}{4}$ " carriage bolt into the holes of the uprights. The nylon washer is already installed in the upright. Affix the $\frac{1}{4}$ " wing nuts.

Lock it in place with metal hooks A at the last notch.

Insert a ¼" X 2¼" carriage bolt into the holes of the stabilizing posts (inside to outside). The nylon washer is already installed in the posts. Affix the ¼" wing nuts. Unfold the back section of the loom and lock it in place with metal hooks B.

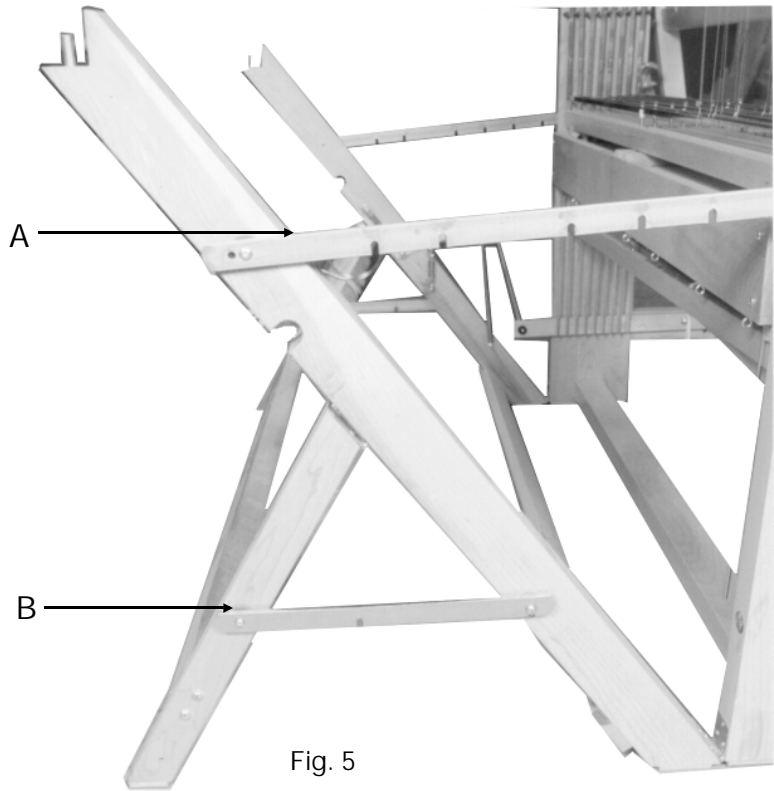

Fig. 5

TREADLE SET ASSEMBLY

Assemble the treadle set (in or out of the loom).

1 treadle rod 28¾" with one push nut already on one side.

10 treadles

8 wood spacers 1½"

3 treadle blocks

4 x 9/16" washers

1 push nut to be installed after the set is on the loom.



Fig. 6

4 washers 9/16" are installed between treadle and treadle

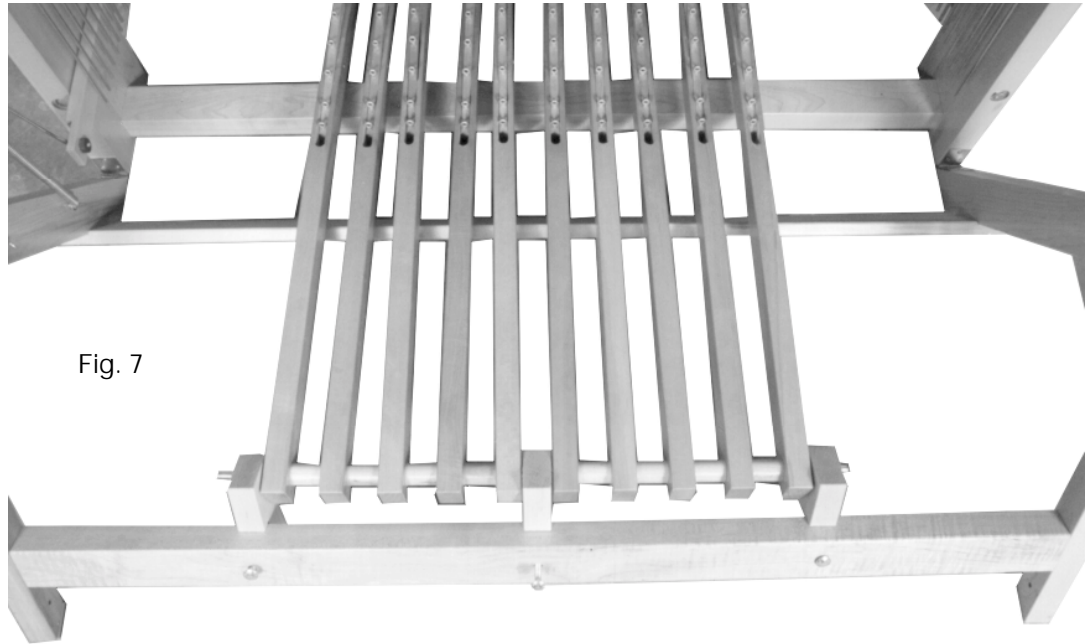

Fig. 7

Affix the treadle set
(from outside to inside of the loom)
3 washers 5/16" (inside of the loom)
3 Square nuts 5/16"



Fig. 8

TREADLE SEPARATOR

Put the treadle separator in top of the loom middle cross-member and secure using 2 1½" round-headed screws #8.

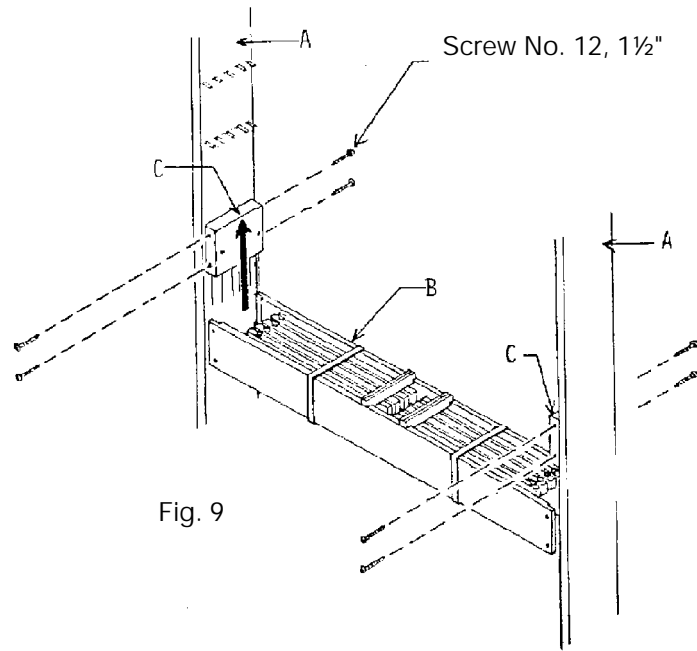

Fig. 9

Slide jack box B along the middle posts A, from bottom to top, and affix it to blocks C using eight 1½" (40 mm) round-headed screws no. 12.

NOTE: The board which has 10 screws across it is the one that goes in the front, bottom of the loom.

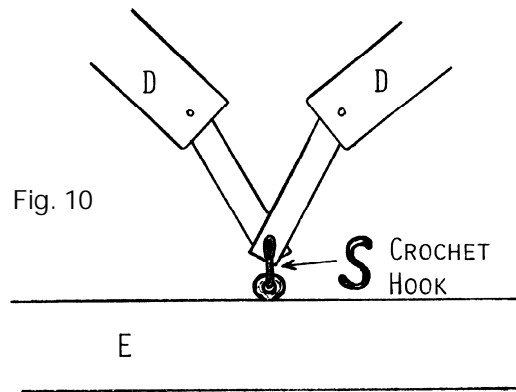

Fig. 10

Remove the saran wrap tape and put the "S" hook of the jacks D inside the eyelet of the lam E.

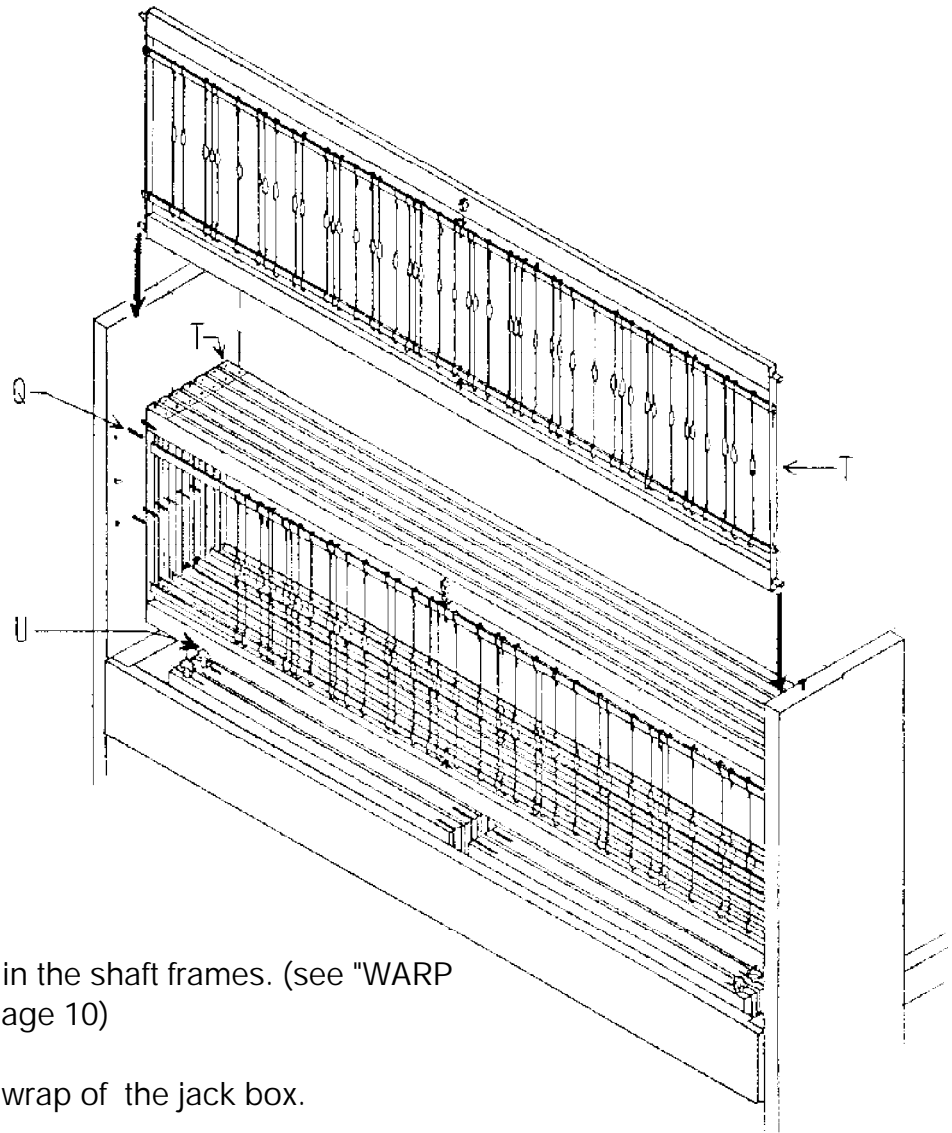

Fig. 11

Install the heddles in the shaft frames. (see "WARP AND WEAVE" on page 10)

Remove the saran wrap of the jack box.

Slide shaft frames T between dividers Q.
The shaft frames must rest on the plastic supports U of the jacks (harness guides).

The Leclerc Logo must be on top, facing the front of the loom.

NOTE: Some shafts may be tight between the castle frame until the castle top is attached.

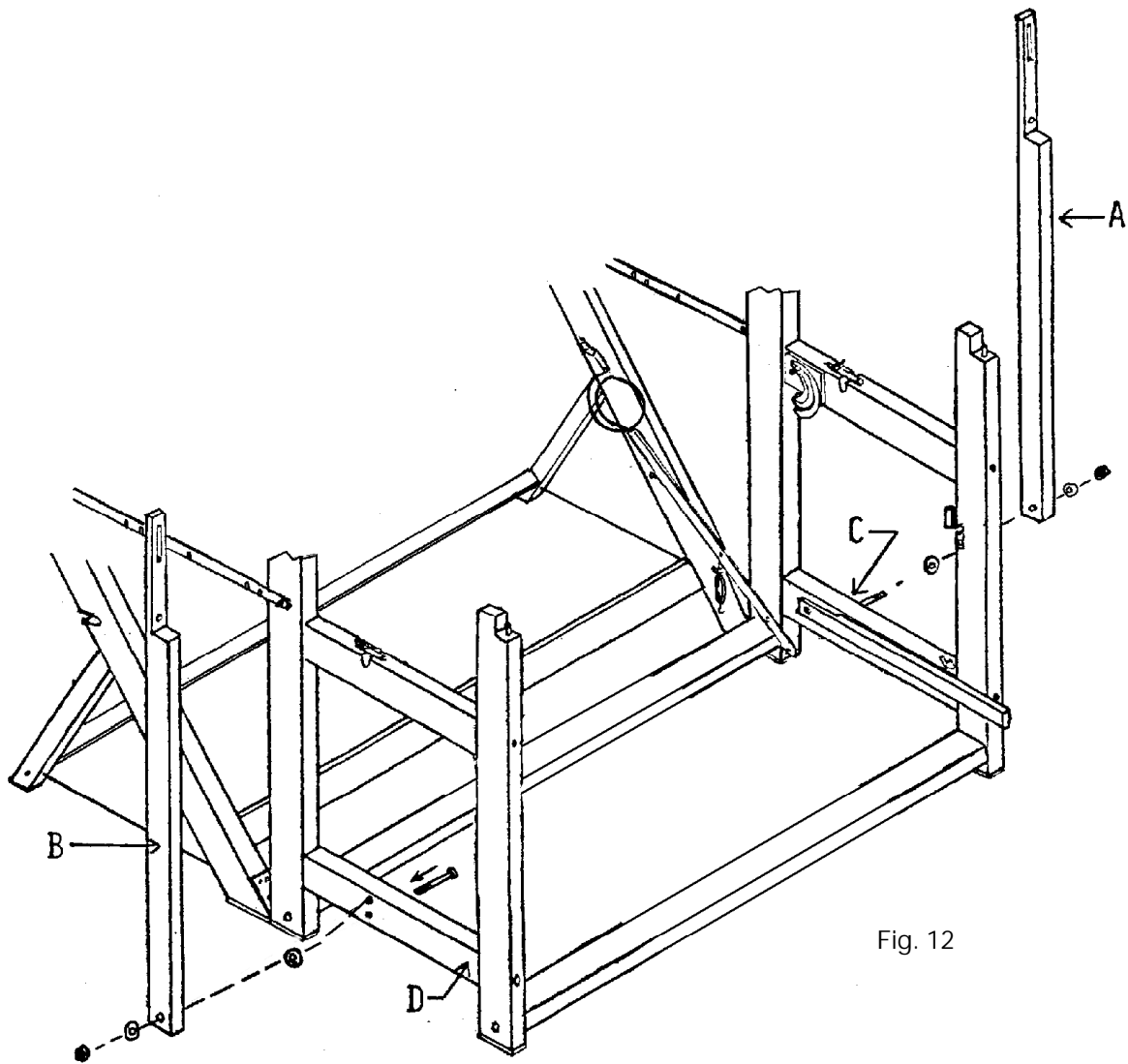

Fig. 12

- NOTE: 1) You will have to remove the brake treadle in order to be able to insert the right side carriage bolt.
- 2) Hammer the carriage bolt inside the hole so it will lock while you will screw the auto lock nuts.

Using 5/16" x 3½" (8 mm x 89 mm) carriage bolts, affix swords A and B to the lower front cross-members C and D. Insert the bolt from the inside into the **upper hole** (jack type loom). Place a 5/16" (8 mm) steel washer between the cross-member and the sword and another on the outside. Then add a 5/16" (8 mm) nylon auto lock nut.

The grooves on top of the swords must be in front.

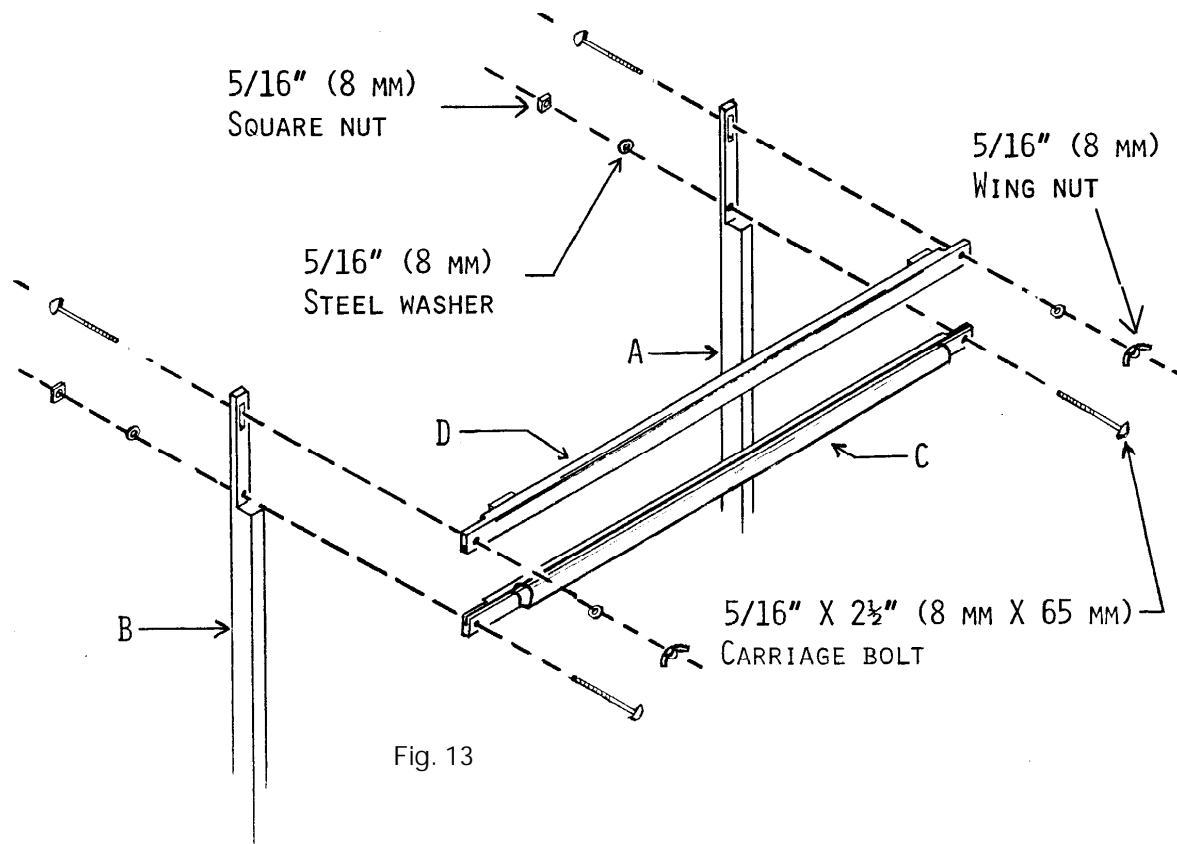

Fig. 13

Using 5/16" x 2½" (8 mm x 65 mm) carriage bolts, 5/16" (8 mm) steel washers, and square nuts, affix batten sley C to the lower holes of swords A and B. (Fig. 13)

NOTE: The batten sley does not have polyvinyl bumpers but it has a shuttle race.

Using 5/16" X 2½" (8 mm X 65 mm) carriage bolts, 5/16" (8 mm) steel washers, and wing nuts, affix batten handtree D to swords A and B. (Fig. 14)

NOTE: The batten handtree has polyvinyl bumpers.

The slots of the batten sley and handtree must face each other.

TREADLE SPRINGS

Insert the Spring Rod and Springs in the Screw Eyes below the Jack Back Board aligning one spring above each treadle.

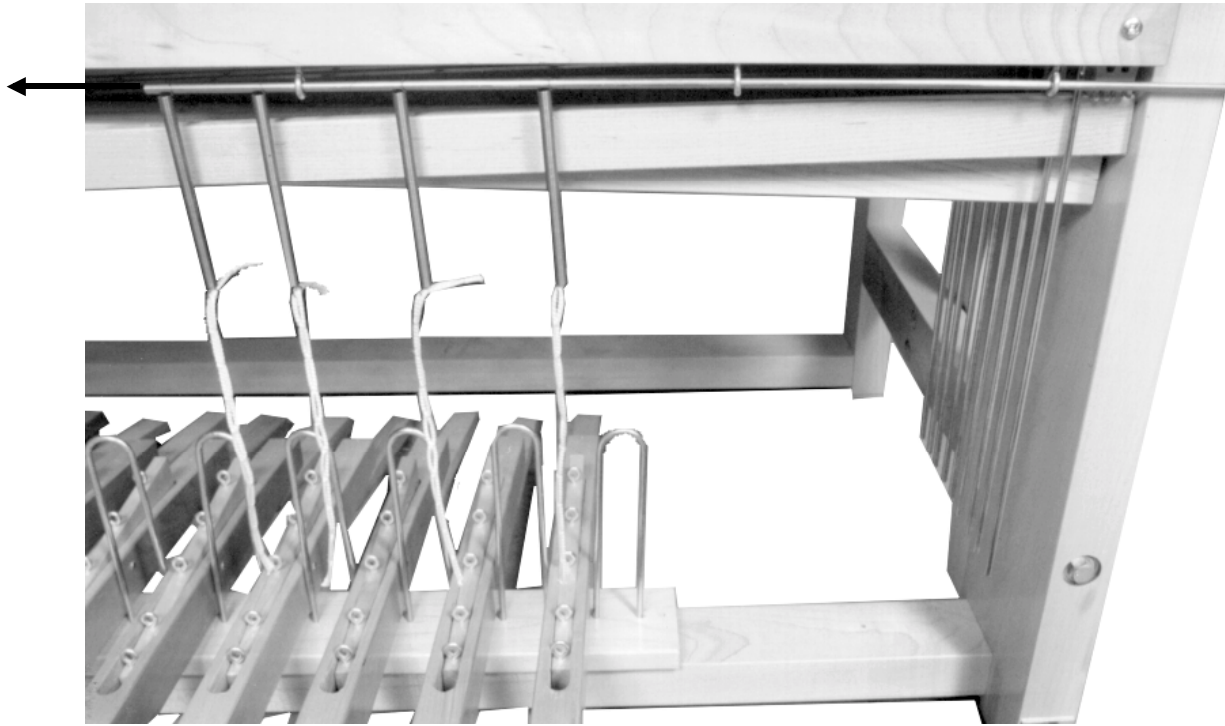

Fig. 14



Using four 1½" flat-headed screws no. 12, affix the castle top on top of middle wide post (castle). Make sure to screw in to the pre-drilled holes.

Fig. 15

WARP BEAM INSTALLATION

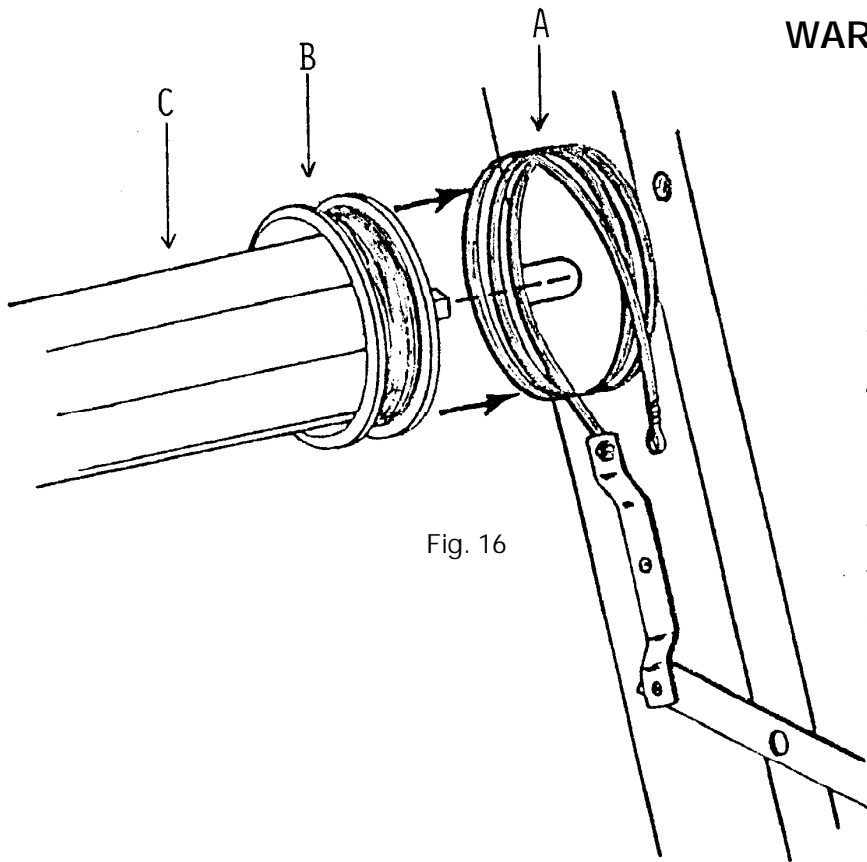

Fig. 16

Hold the circular wire brake shoe A slightly to the rear of the loom, **but do not unroll it.**

Insert the brake drum B into the wire brake shoe A. Then, install the ends of the warp beam C into the grooves of the back posts. (Fig. 16)

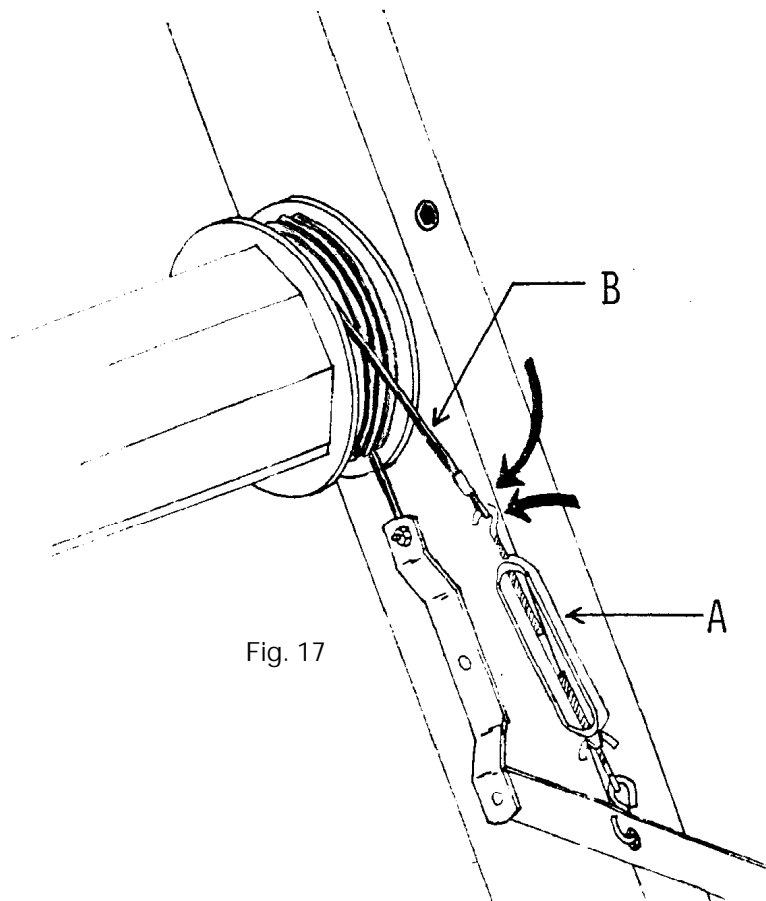

Fig. 17

Hook turnbuckle A to flat wire circle B. (Fig.17)
Adjustment instructions will be given later.

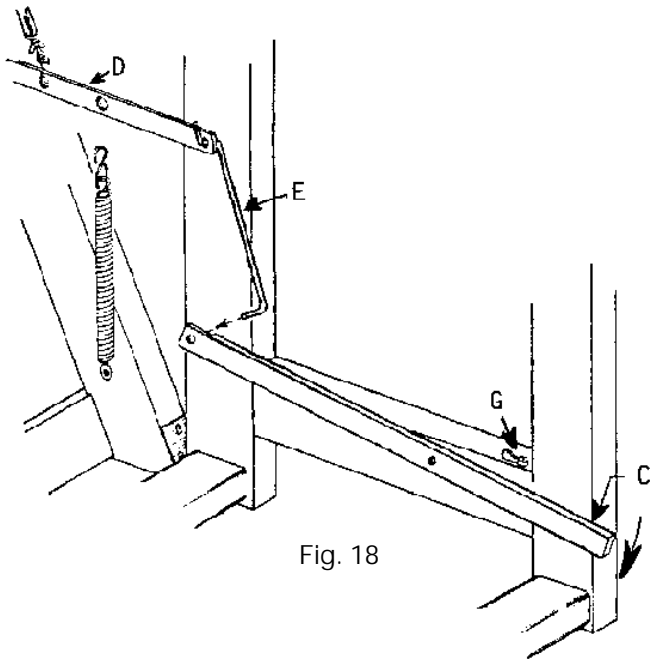

Fig. 18

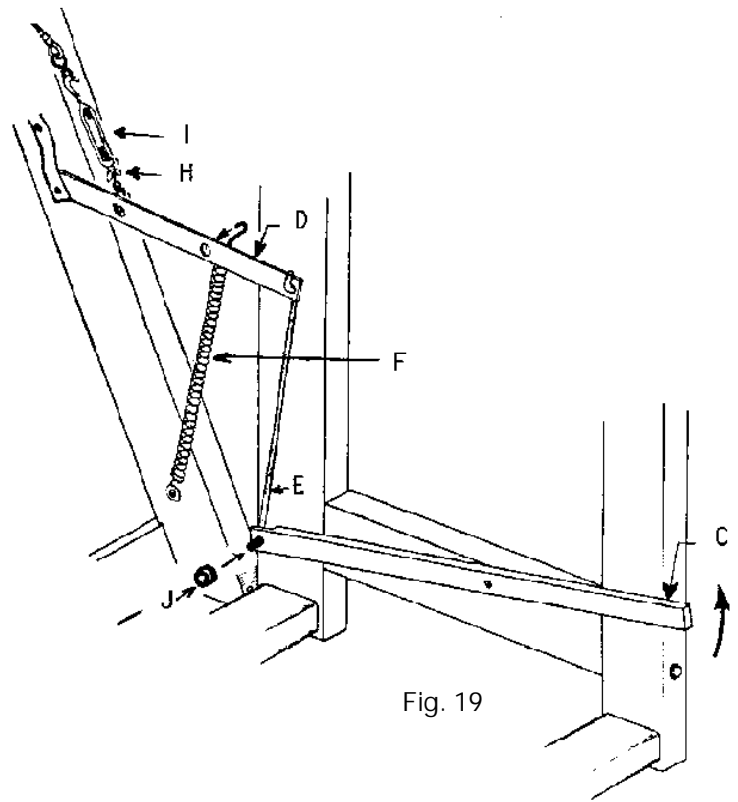

Fig. 19

Using metal rod E, join treadle C to lever D. First insert the double-cornered end of the metal rod into lever D; then insert the other end of the metal rod into treadle C while the treadle is depressed. (Fig. 18)

Raise treadle C as high as possible then hook spring F to lever D. (Fig. 19)

BRAKE ADJUSTMENT:

Release the brake by depressing treadle C and locking it down with the catch G. (Fig. 18)
 The warp beam should turn freely but the brake circular wire should not be too slack. If the tension is too great, unscrew the wing nut H slightly and then loosen the turnbuckle I. If the tension is too slack, tighten the turnbuckle I slightly and then the wing nut H.
 (Fig. 19)

You will add a black rubber ring J to the lower end of the rod E, to prevent the rod from slipping out. (Fig. 19)

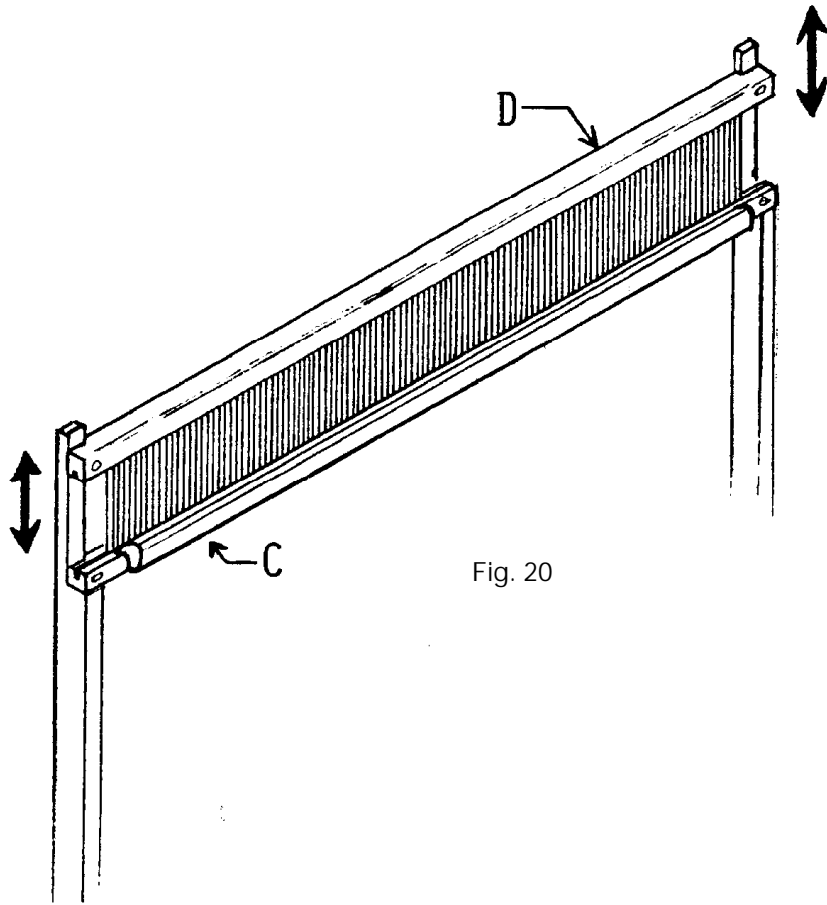

Fig. 20

Place the reed between batten sley C and handtree D. (Fig. 20)

When the wing nuts are loose, the batten handtree can slide vertically in the sword slots. The reed must then be secured between the batten sley and handtree by tightening the wing nuts.

If the batten does not touch the two bumpers equally, loosen the bolts of the batten sley and handtree and exert pressure on the batten centering it in its proper place. Tighten the bolts again.

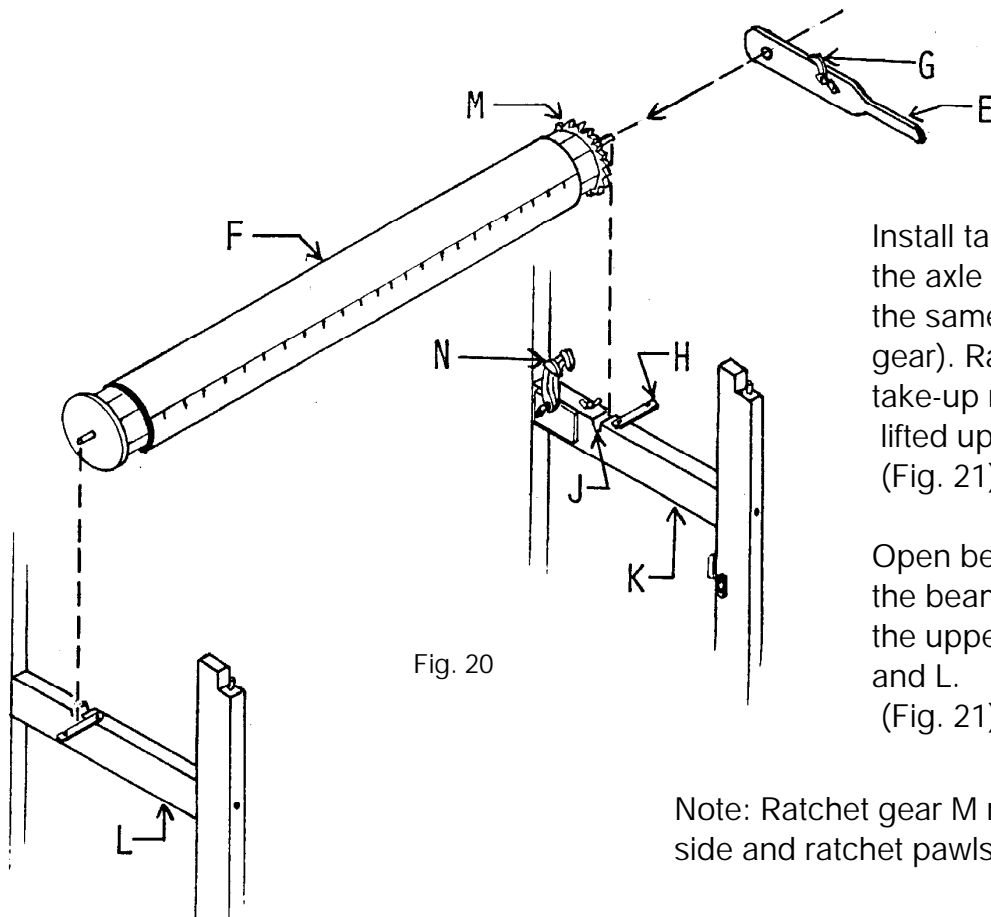

Fig. 20

Install take-up motion handle E on the axle end of cloth beam F (on the same side as the ratchet gear). Ratchet pawl G of the take-up motion handle must be lifted up. (Fig. 21)

Open beam latches H and place the beam ends in the slots J of the upper side cross-members K and L. (Fig. 21)

Note: Ratchet gear M must be on the right-hand side and ratchet pawls N must be lifted up.

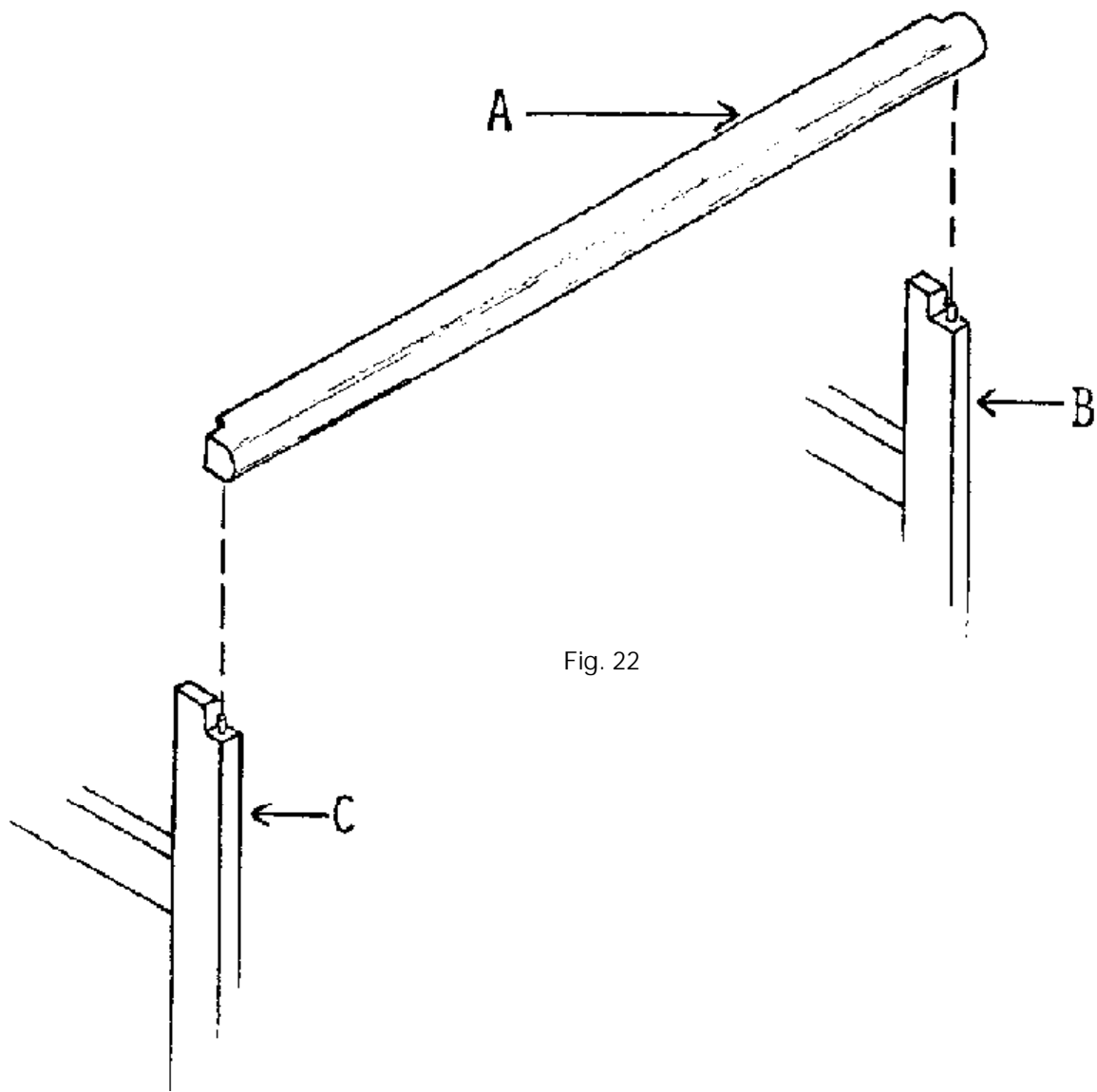

Fig. 22

Affix one of the breast beams A on the top of the front posts B and C. (Fig. 22)

Affix the other breast beam on top of the back posts.

NOTE: To avoid splitting the front posts, slightly insert the breast beam onto the metal pin. Be sure that it is in the right position before inserting it completely.

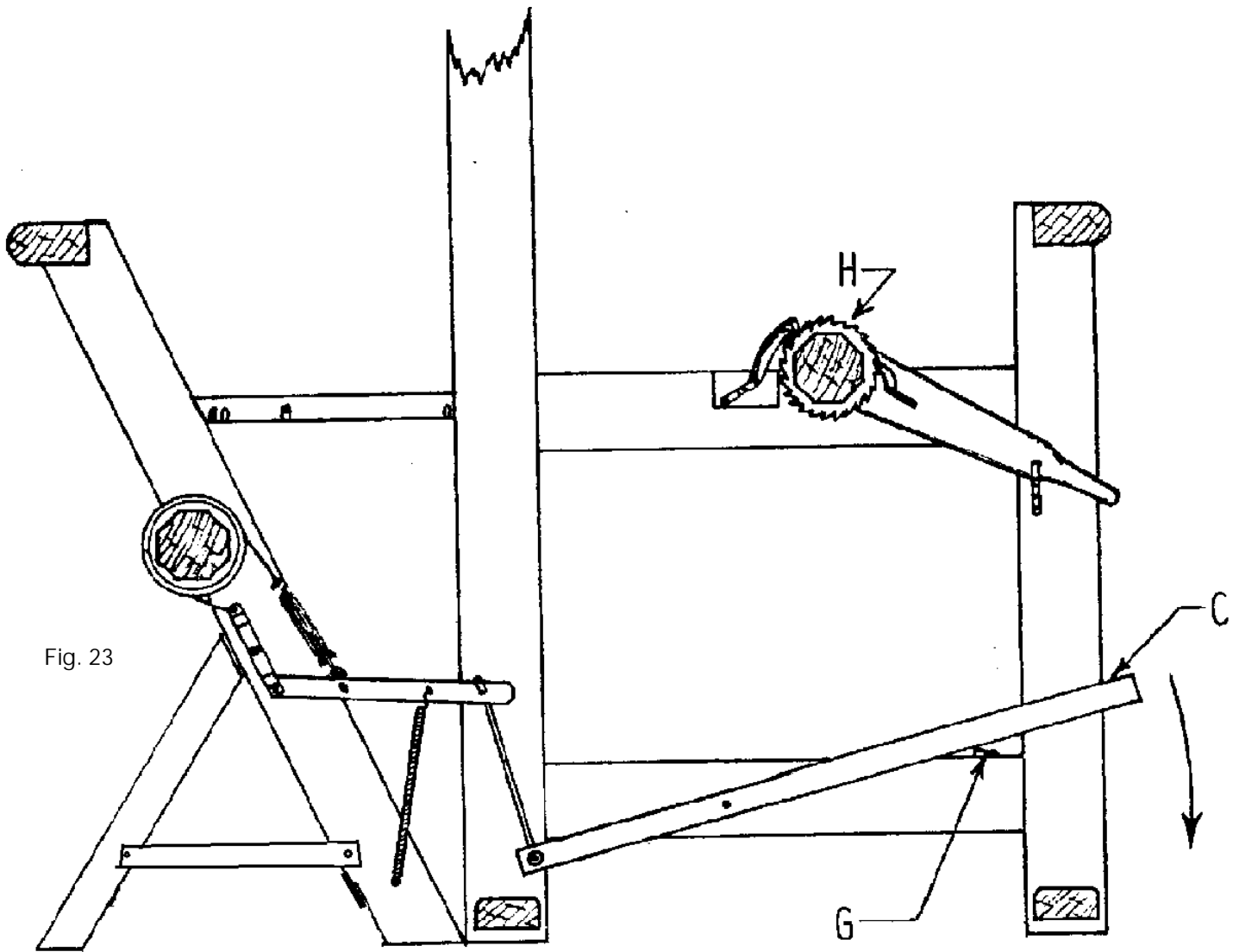

Fig. 23

FOLDING LOOM AND BEAMING:

Release the brake by depressing treadle C and by locking it down with catch G. Release the 4 metal hooks and fold the back of the loom.

WEAVING:

To advance the warp, depress brake treadle C and turn cloth beam H at the same time. Then release brake treadle C and advance the cloth beam until the next notch in the ratchet gear is reached. If this is too much tension, gently depress the brake treadle until the desired tension is obtained. (Fig. 23)

MORE INFORMATION:

See "WARP AND WEAVE", page 87.

FIRST TREADLE TIE-UP

Select any treadle and tie the Lams to the Treadles using the 7" cords supplied with the loom. Take the threading hook to help pass the cord through each hole of the lam.

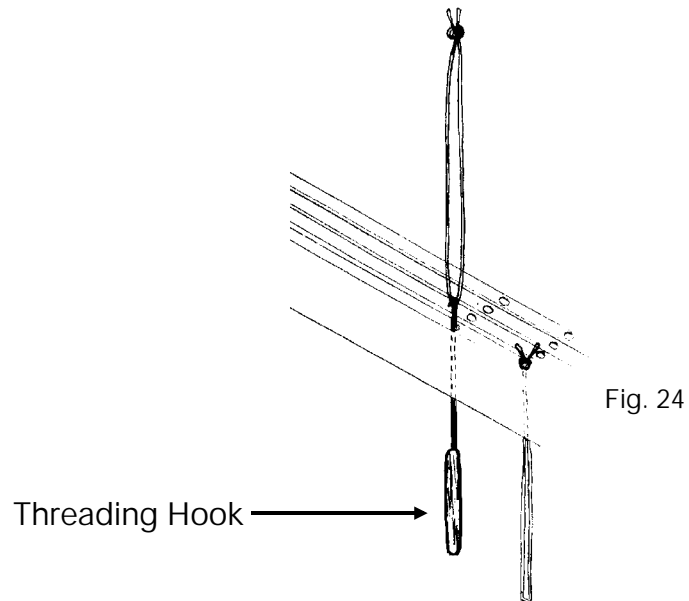

TREADLE HOOK AND ROCKER LOOP CORD

Slide the Treadle Hook through the Screw Eyes and Cord Loops. Before the last Screw Eye, insert the Hook through the Treadle Spring and secure. In the Treadle rest position (up) there should be no or very little tension on the Spring. However slack on those cords is not desirable. When all treadles are tied up, they should be at the same height.

Rocker loop cord

Install the Treadle Rocker Loop Cord on the Anchors (Screw Heads) using the marked points at the Anchor. (see diagram)

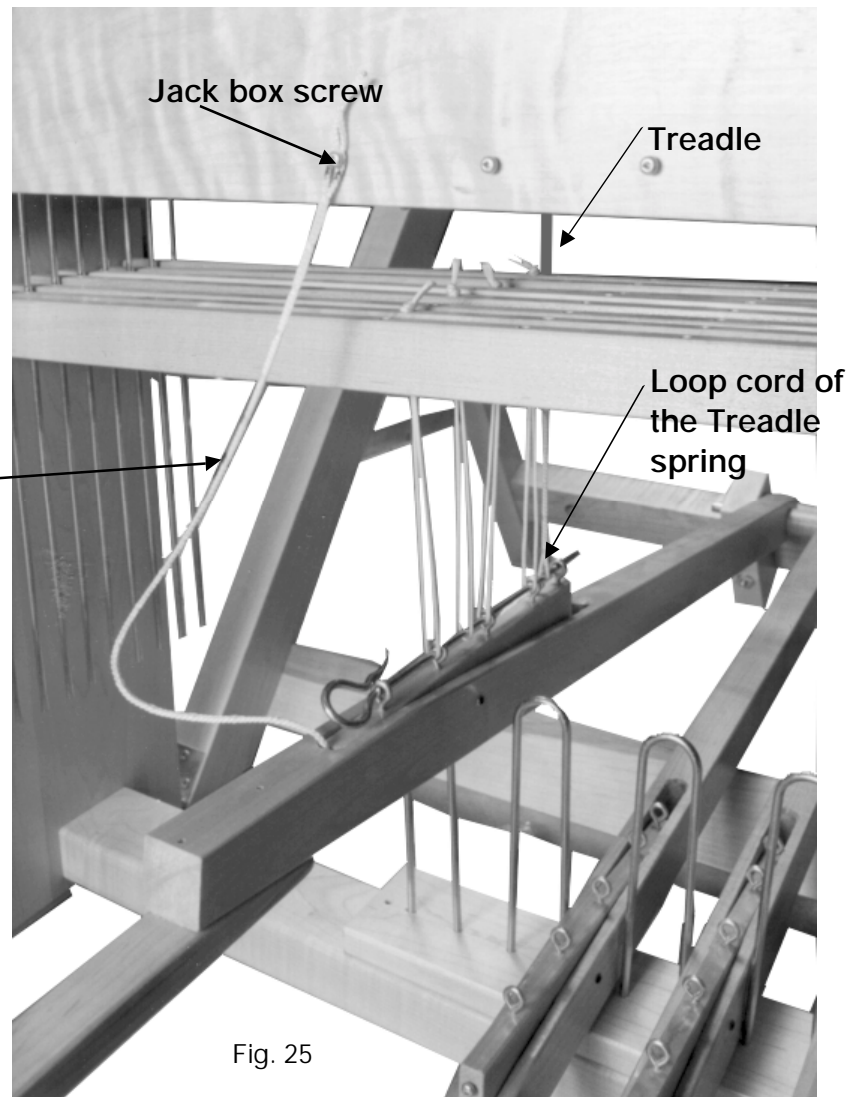

Fig. 26

FIRST SHED

When you depress the Treadle, the Rocker Loop Cord raises the front of Rocker setting the Shafts at the corre Level.

Rocker loop
cord

Fig. 27

Rocker screw



VIEW FROM THE BACK OF THE LOOM SHOWING THE TREADLE AT REST POSITION AND DEPRESSED.

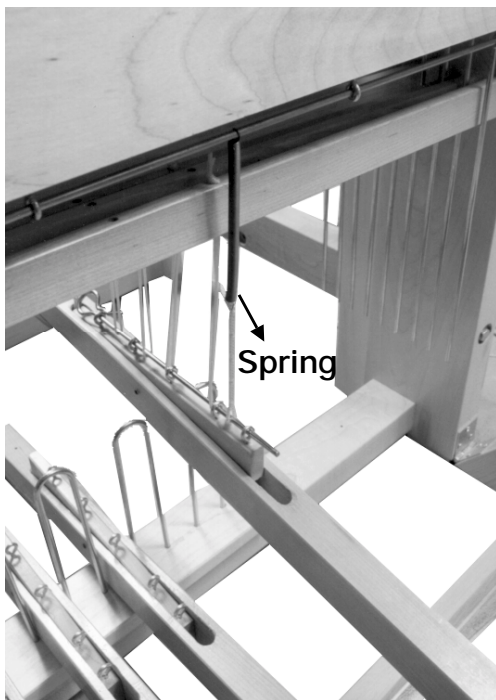

Fig. 28

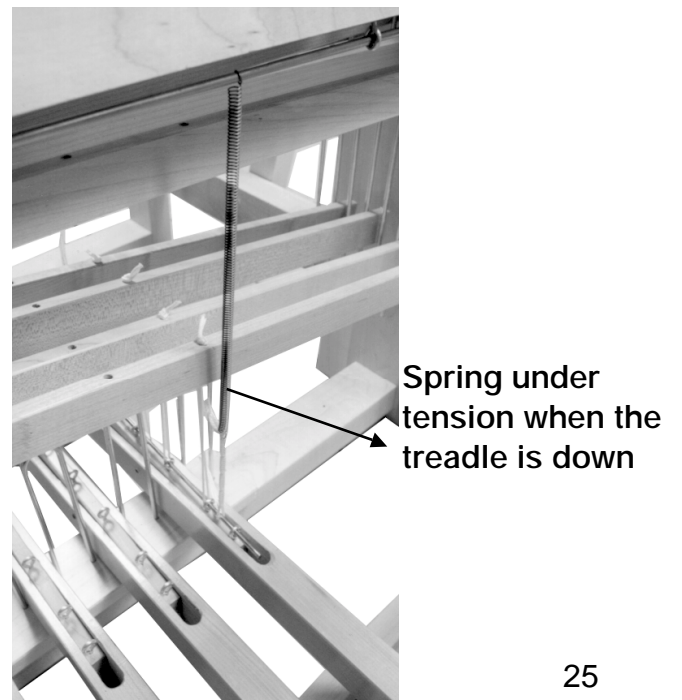

Fig. 29

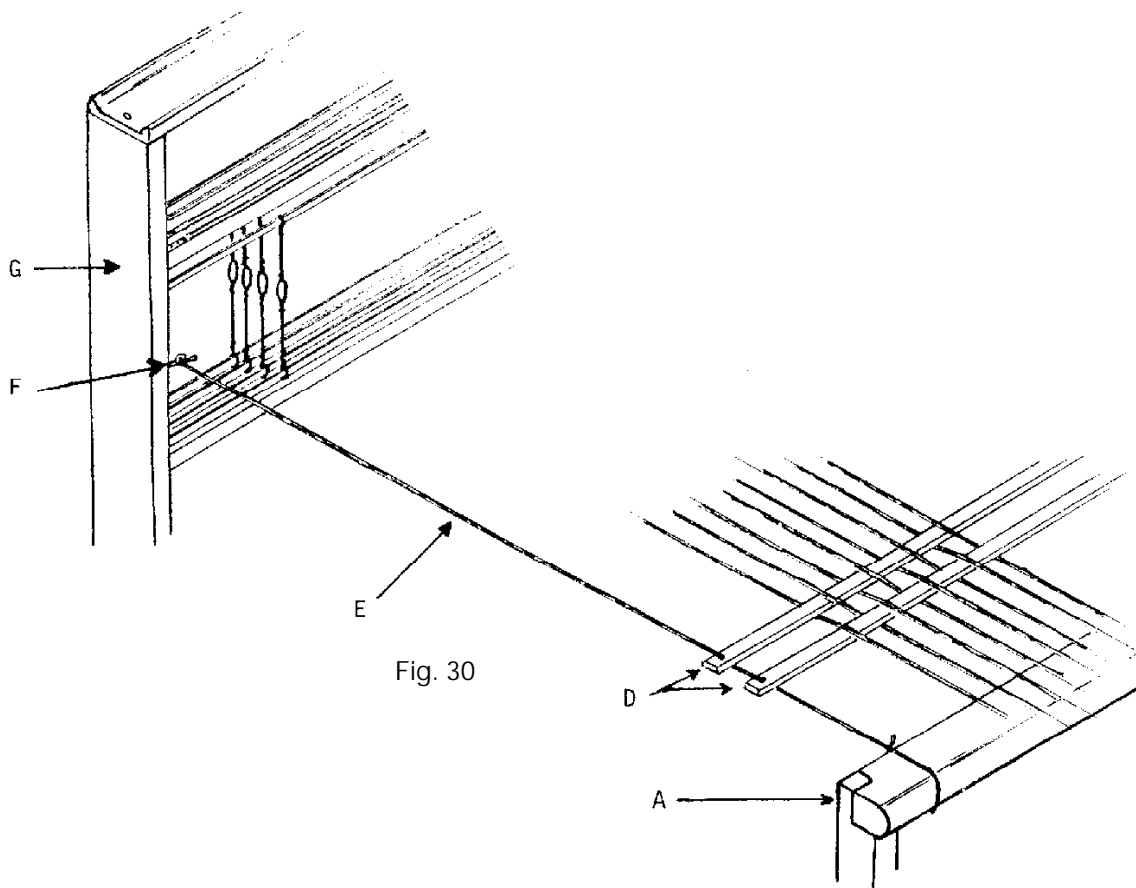

Fig. 30

Affix screw eyes F to the holes inside middle posts G.
Pass a string C through the holes at each side of the lease sticks D and tie them to the screw eyes and to the thread beam A. The lease sticks will be held at the right height and distance for easy threading. (Fig. 30)

If the loom is equipped with a sectional warp beam, affix the rake-like pieces (following the instructions supplied with the sectional warp beam) and do the following instructions on the cloth beam only.

If the loom is not equipped with a sectional warp beam, affix the apron to the warp beam with tacks and do the following procedures on the warp and cloth beams.

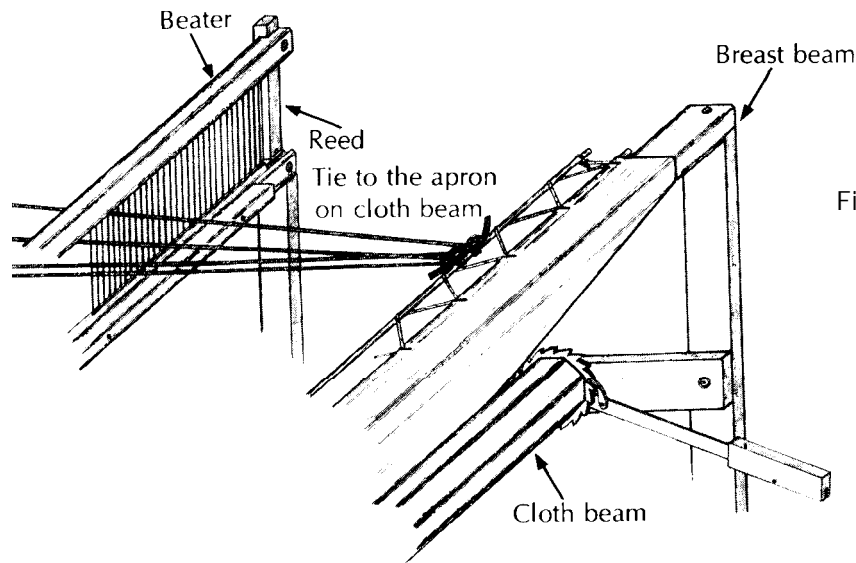

Fig. 31

Insert a warp rod into the apron border.

For 27", 36" and 45" loom
(70cm, 90cm and 115cm)

For 60" loom
(150cm)

Cut the 5 yard (4.5m) cord in half.
Use one half of the cord to lace the
apron warp rod to a second warp rod.
This second warp rod will be used to
attach warp threads.

Use a 5 yard (4.5m) cord to lace the
apron warp rod to a second warp rod.
This second warp rod will be used to
attach warp threads.

For more information see the book "Warp & Weave" supplied with the loom.

We at Leclerc encourage Weaver feedback on this and all
our products. Please
send your comments to Leclerc Loom Co.

HAPPY WEAVING

ADJUSTING THE SHED

The key to a wide clean shed is the proper adjustment of the Rocker Loop Cord. Once you have completed the hookup of the Cords and Springs, start at one end of the Treadle Set and depress each Treadle one at a time noting the position of the bottom Shed. Adjust each Shed by shortening or lengthening the Loop Cord. When properly adjusted, the bottom Shed of each Treadle should just kiss the Race Plate and the top Shed should be uniform across the width of the Loom. (see diagrams for examples)

Picture #32 shows an uneven Shed caused by Rocker Loop Cords being out of adjustment.

Picture #33 shows properly adjusted Rocker Loop Cords with the bottom Shed just kissing the Race Plate and the Top Shed uniformly even across the width.

It is very important to maintain a reasonable amount of tension on the Warp when making adjustments and while weaving in order to keep a wide, clean Shed.

The design of the system provides a greater lifting force on the Shafts with considerably less leg pressure required to depress the Treadles. With a few Picks on each new project, the Weaver will find the correct Warp tension required to produce the desired PPI (Picks per Inch) in the Cloth, while maintaining a wide, clean Shed.

HAPPY WEAVING



Fig. 32



Fig. 33