

**COMPACT 24”
8 SHAFTS
1022-0001**



1573 Savoie
C. P. 4
Plessisville, Qc. Canada
G6L 2Y6

TEL: 819-362-7207
FAX: 819-362-2045

www.leclerclooms.com
info@leclerclooms.com

On receiving the loom, unpack and lay out the loom components. Do NOT discard any packing material until all parts are inventoried.

Check the parts received against the parts list on pages #2 to #6 of the assembly instructions. Report any discrepancies to Leclerc immediately.

To assemble this loom, a minimum of 2 people are needed but it is recommended you use 3.



Loom Prepared by: _____

Inspected by: _____

Date: _____

Pare-chocs sous cadres aminci



Installed side handles

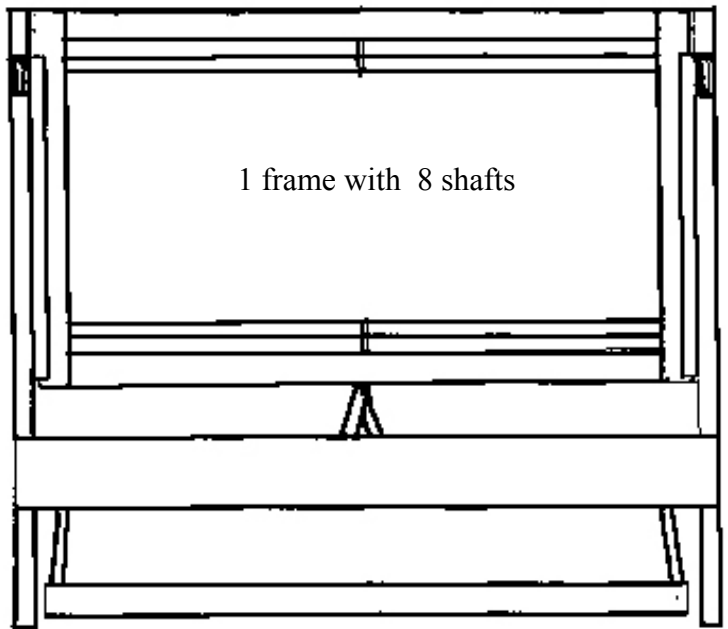

1 frame with 8 shafts

10½"



600 heddles 10½"



1 threading hook



1 red screwdriver & 1 black

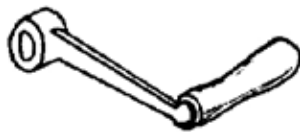

1 crank (Octagonal)

Note for Leclerc in French :
Enfiler les rondelles 3/16"
dans chaque cordes et attacher
par paquet de 12 cordes.



5x12 treadle cords 9" with
washers 1/8" x 3/16"



1 - 5 yard cord
2 - 10 yard cords



1 boat shuttle (6122-1000)



1 adjustable wrench



1 friction brake spring

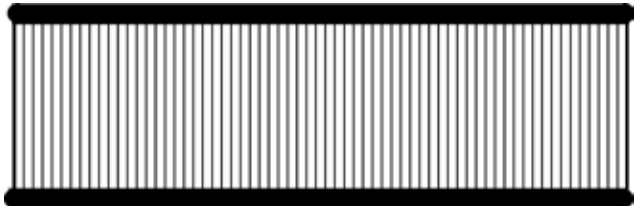

1 reed



2 lease sticks 25" (metal)

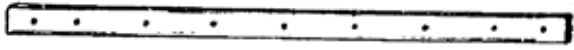

2 beam sticks 24½" (metal)



2 warp rods (metal)

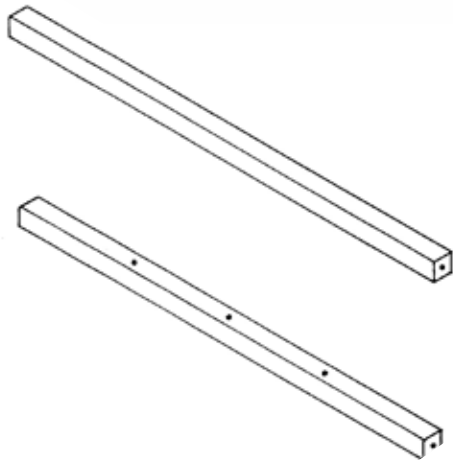



1 cloth beam 25"

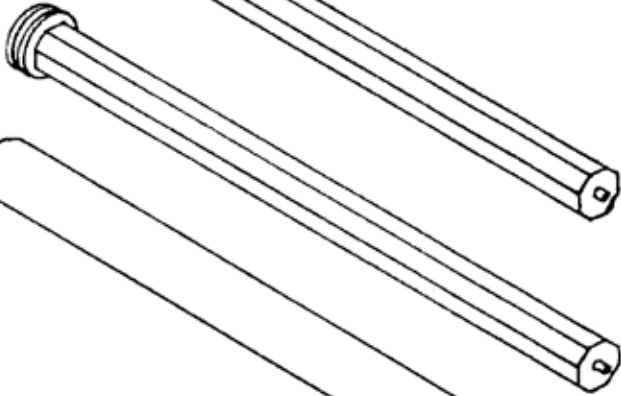

1 warp beam 28 9/16"



1 thread beam 29 1/2"

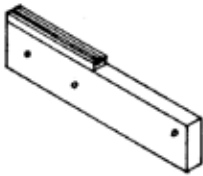

1 left hand side cloth beam support

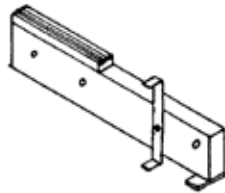

1 right hand side cloth beam support with ratchet pawl 10 1/2"

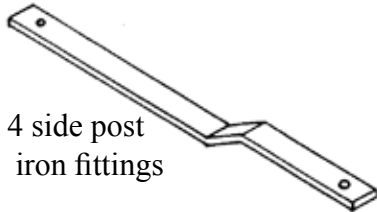

4 side post iron fittings



5 wood treadle blocks



1 take-up motion handle with 12" loop cord + 1 eyescrew

LECLERC NOTE:
Oeillet légèrement ouvert

Treadle springs



10 springs with loop cords and knot

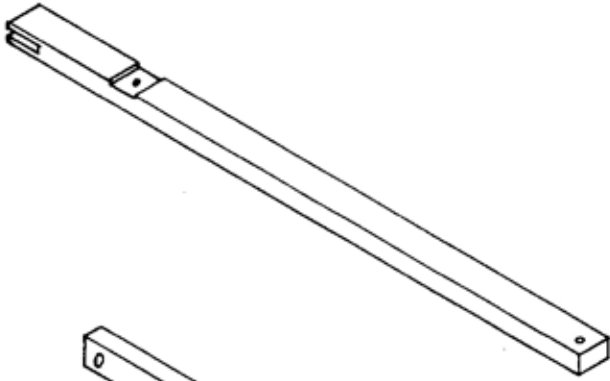

2 batten swords 27 1/4"

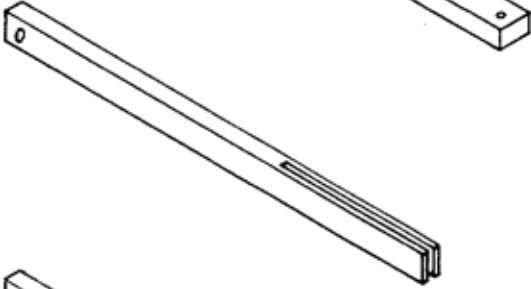

10 treadles 20"

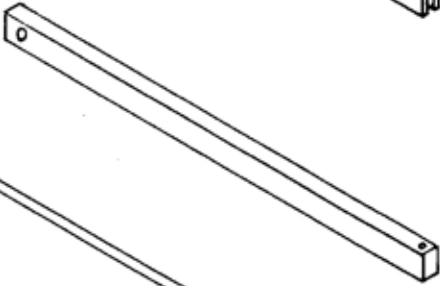

1 brake treadle 20"



1 treadle rod 5/16" x 30"

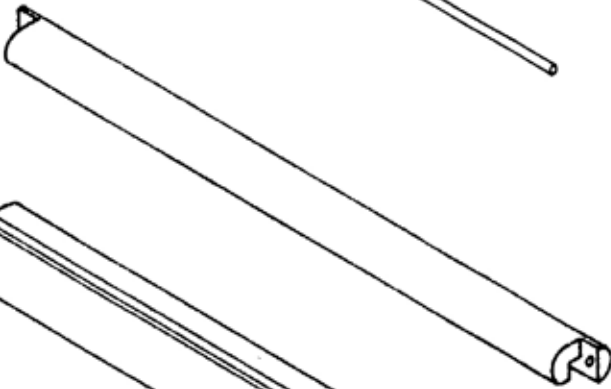

1 batten handtree 29"

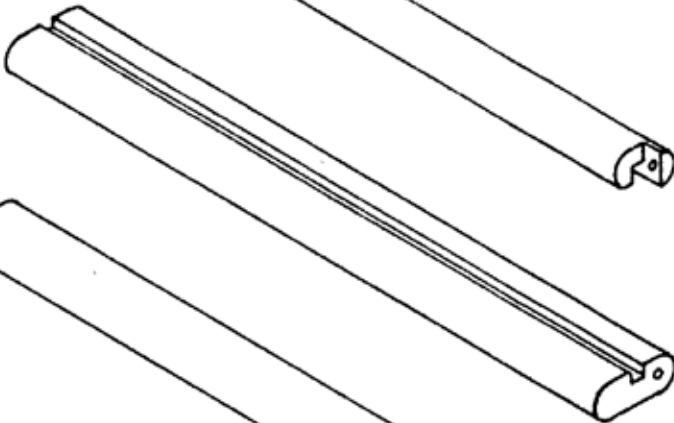

1 batten sley 27 3/4"

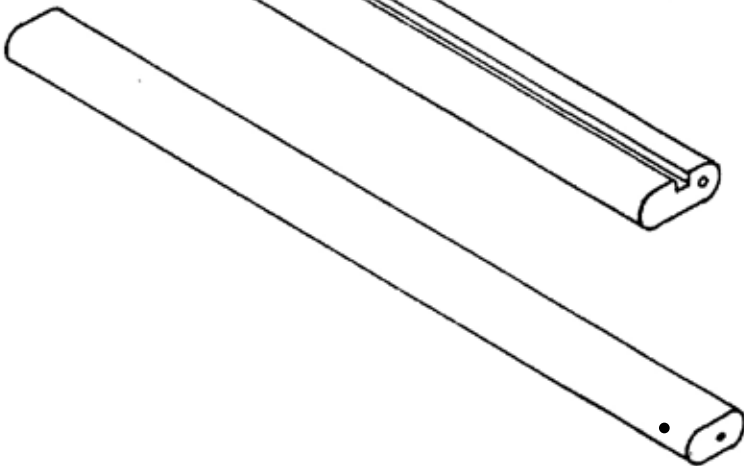

1 breast beam 31"

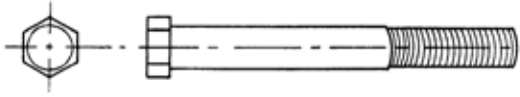

Machine bolts
1 X - 5/16" x 3"

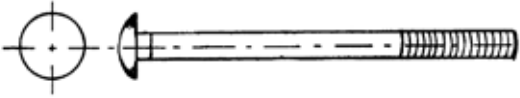

Carriage Bolts
2 X - 1/4" x 2 3/4" (6mm x 65mm)
2 X - 5/16 x 2 3/4" (8mm x 70mm)
2 X - 5/16" x 2" (8mm x 50mm)

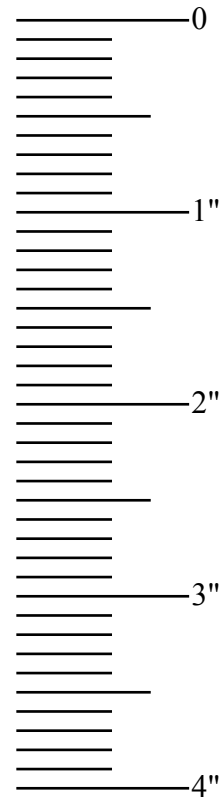

Machine Screw
4 X 2" x 1/4"



HEXAGON NUTS
4 X- Nylon auto lock 5/16"
4 X- Nylon auto lock 1/4"



Metal Washers
4 X - 3/16"
6 X - 5/16"
6 X - 1/4"

Plastic washers
2x -3/16"



Nylon Wing nut for the Warp beam
advance control system



1 loop cords 24" for the brake treadle

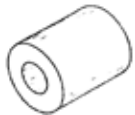

6 X Wooden spacer 1.5"
1 Wooden spacer 1"



Wing nuts
2 X - 1/4" (6 mm)



1 DVD Instruction Video showing all
stages of installation.



Round head screw
11 X - #14 x 2" (50mm)
4 X - #14 x 1 1/2" (40mm)
4 X - #12 x 3/4" (20mm)
10 X - #12 x 3/4" (20mm)



1 book Warp & Weave



1x push nuts 5/16"
for treadle set rod

Fix an iron fitting A on each of the 4 legs . Make sure they are positioned exactly as shown in the diagram below.

Put a 3/16" (5mm) steel washer between the iron fitting and the leg. Screw them in using the 3/4" (20mm) round-headed screw No. 12. Do not over tighten so the iron can move freely.

The screw must be inserted into the smallest hole of the iron fitting.

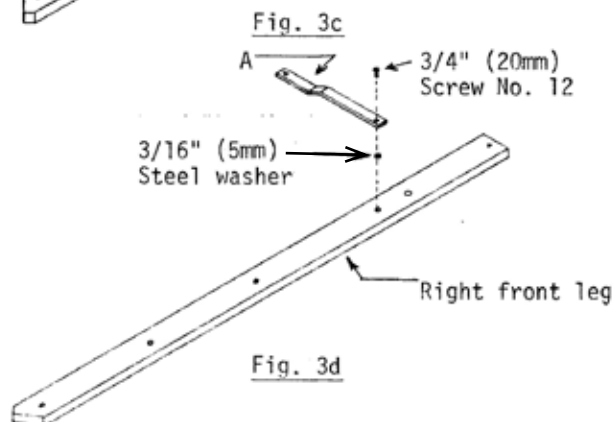
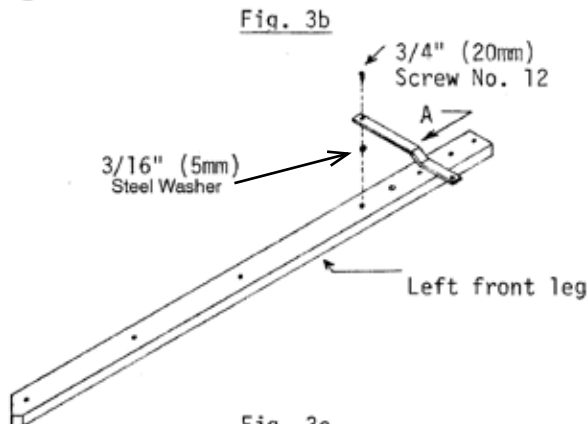
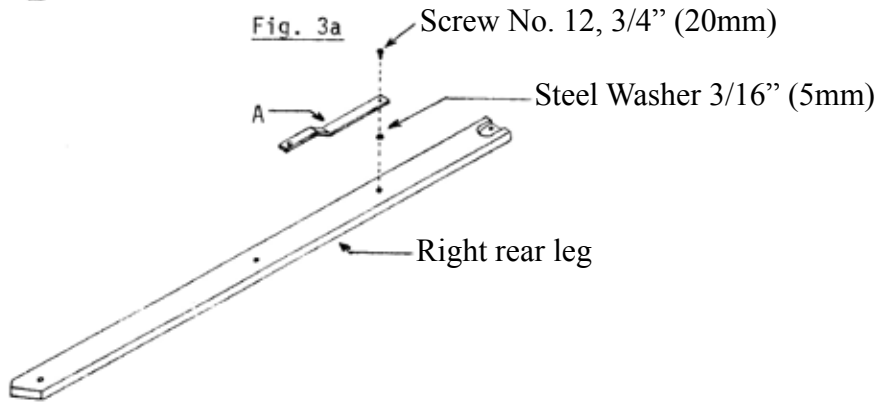
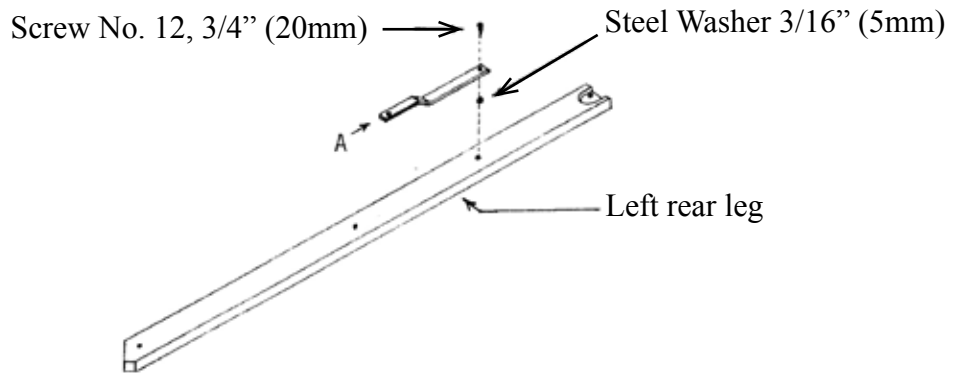

ATTENTION:
Application
of soap to the
screws will
make their
insertion
easier.

Place the loom frame on its right side. Fix the left front A and rear B legs to the left side of the frame with a 5/16" x 2 3/4" (8mm x 70mm) carriage bolt. With a hammer, hit on the head of the bolt until it is even with the leg B. Cross the legs so that the lower end of the leg B is towards the back and the lower end of the leg A is towards the front. Add a steel washer and screw a 5/16" (8mm) lock nut in without overtightening it. You must feel light resistance when you swivel the legs.

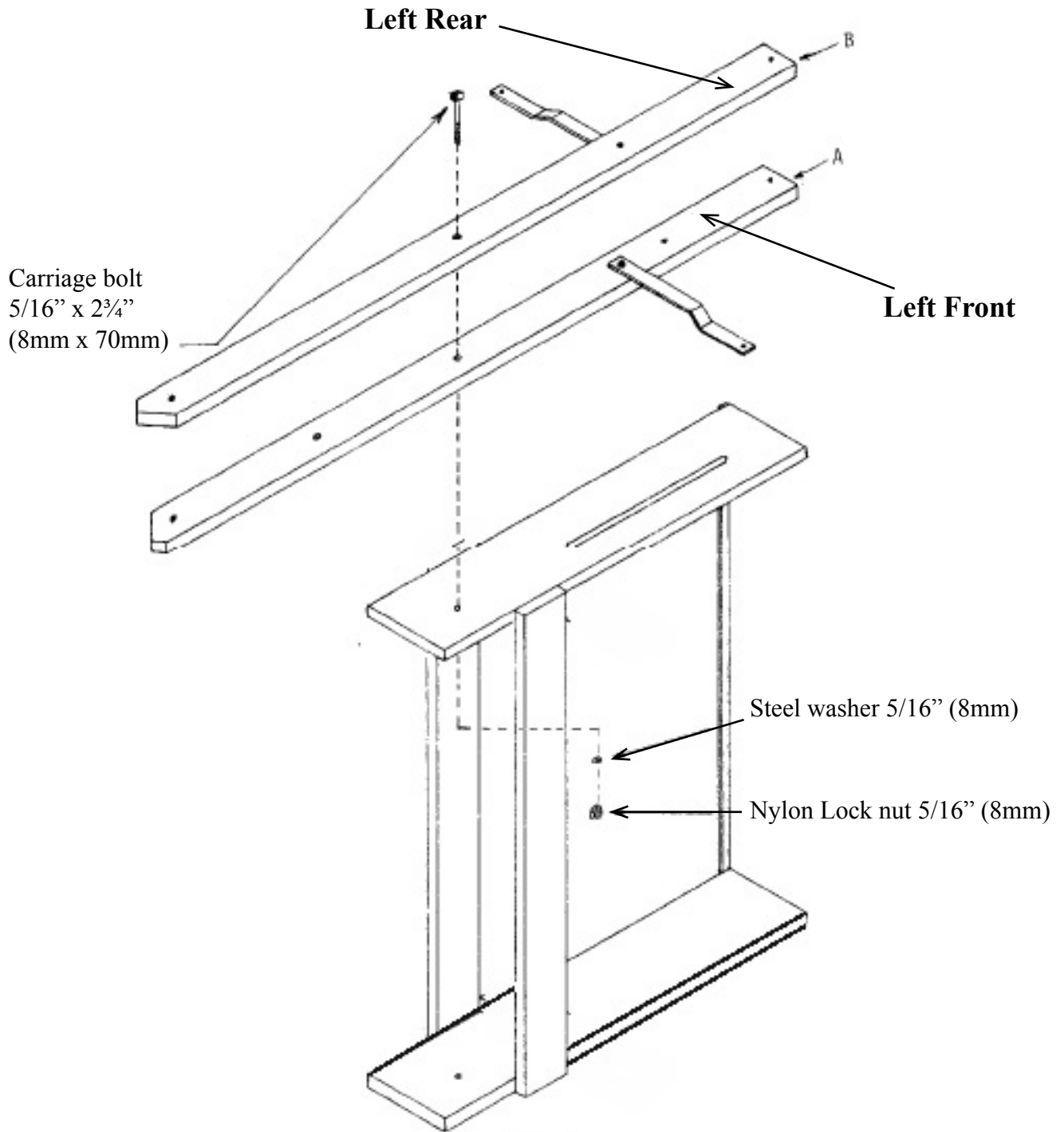

Place the loom on its right side and remove the handle B. Make sure the plastic spacer A is is in place. Install first the rear leg iron fitting D and then the front leg iron fitting (fig.5). Screw back the handle into the lower position. Place the loom on its left side and install the right front and rear legs the same way. Place the loom on its legs.

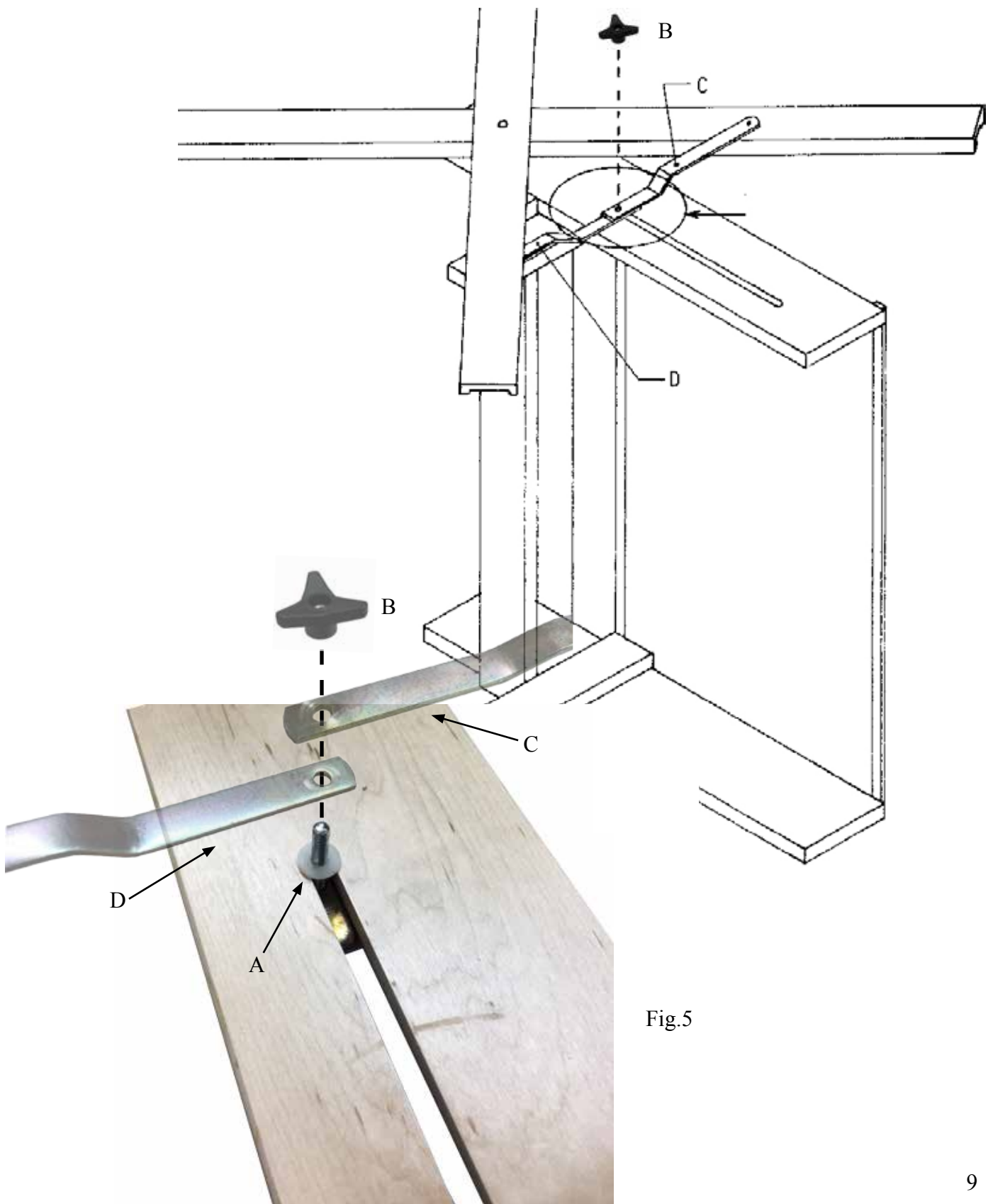
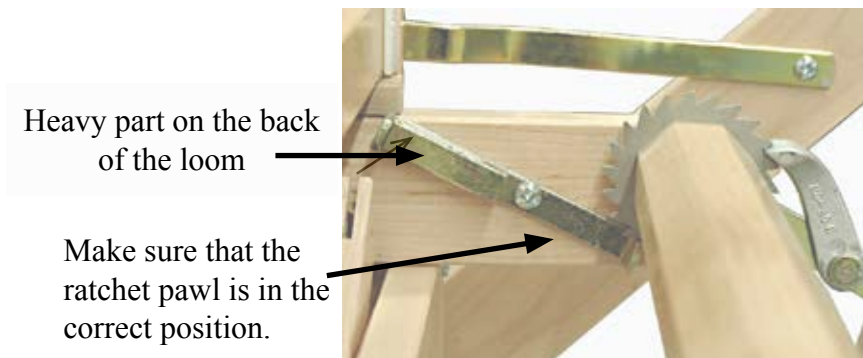
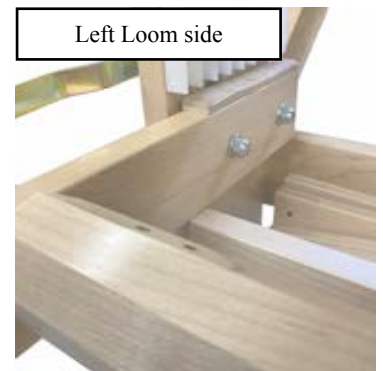
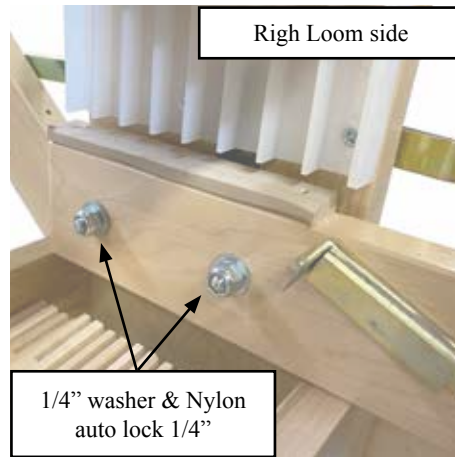
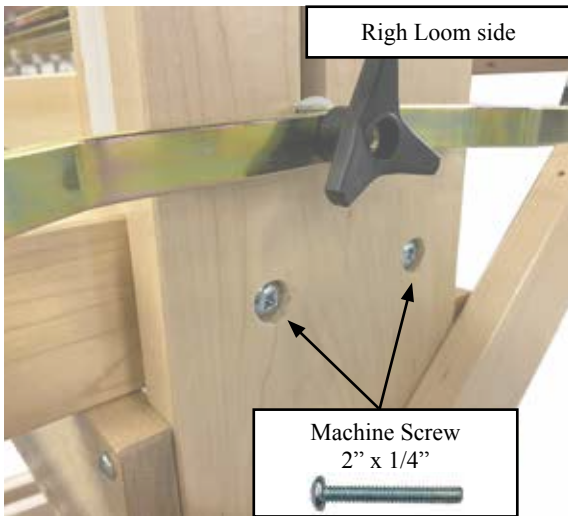
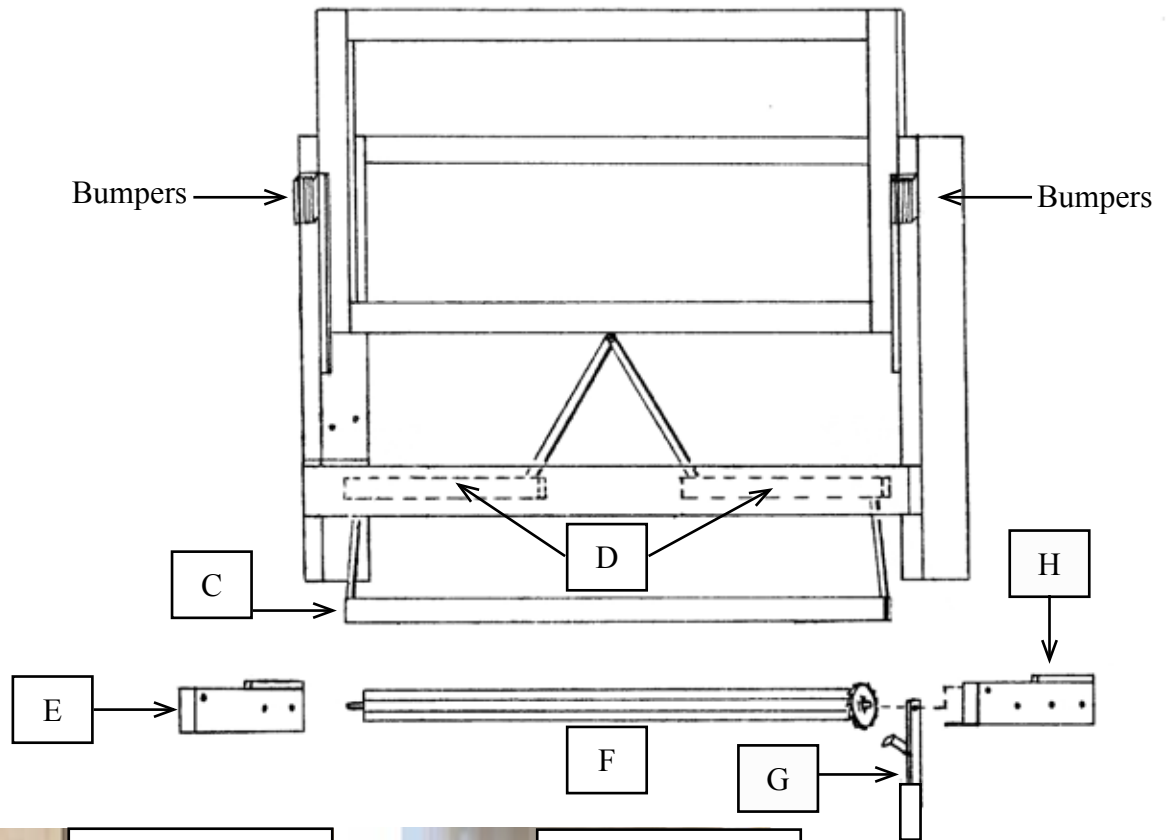
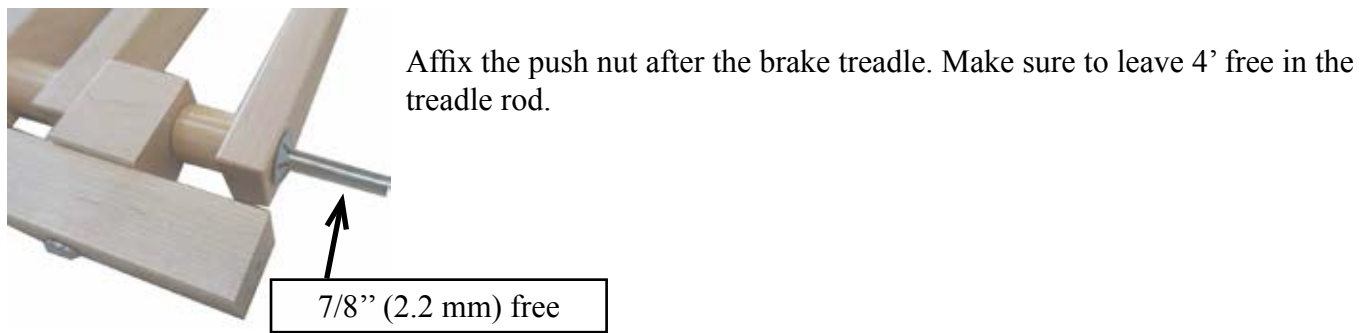
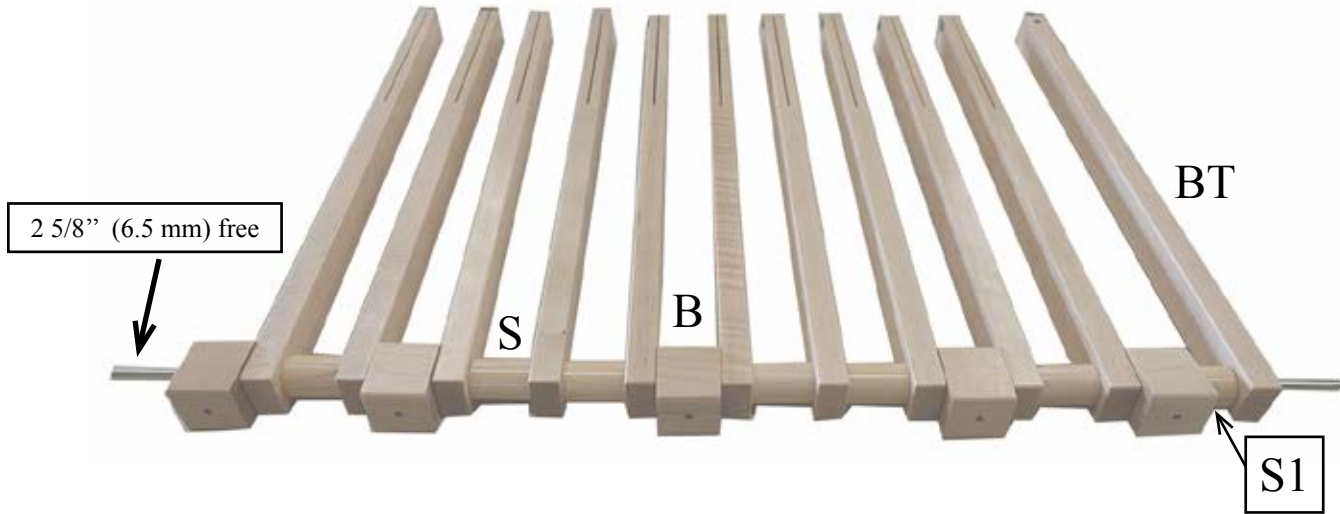

Fig.5

Insert the left support E into the left end of the cloth beam F, then insert the take-up motion handle G and the right support H, into the right side of the cloth beam. Push all these parts between the sides of the loom and fix each support (E & H) using the screwdriver no. 3 and the adjustable wrench. You will need 4 machine screws 2" x 1/4", 4 washer 1/4" and 4 Nylon auto lock 1/4". See drawing and photos.



Assemble the treadle set using the 10 treadles, 5 treadle blocs (B), 6 treadle spacer 1.5'' (S) one spacer 1'' (S1), one brake treadle (BT) and one push nut. Start making the assembly at the left side. Leave 2 5/8'' of rod free at the left side.



Install the treadle set to the loom. Insert the left side rod to the post. Insert the right hand side and affix the treadle cross member with 2 screws no 14, 2'' (50 mm)

Brake treadle

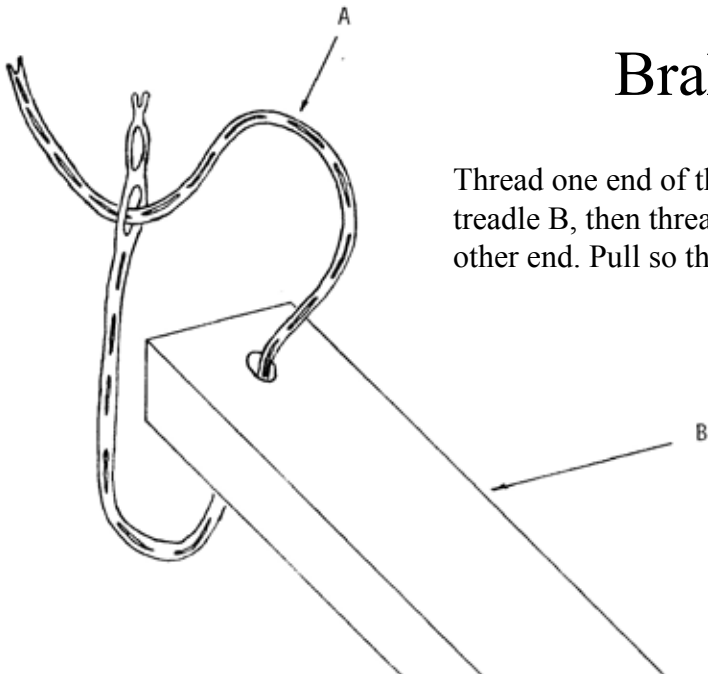

Thread one end of the loop brake cord A into the hole of the brake treadle B, then thread one end of this cord into the second loop of the other end. Pull so that it makes a knot.

New 2020 friction brake system

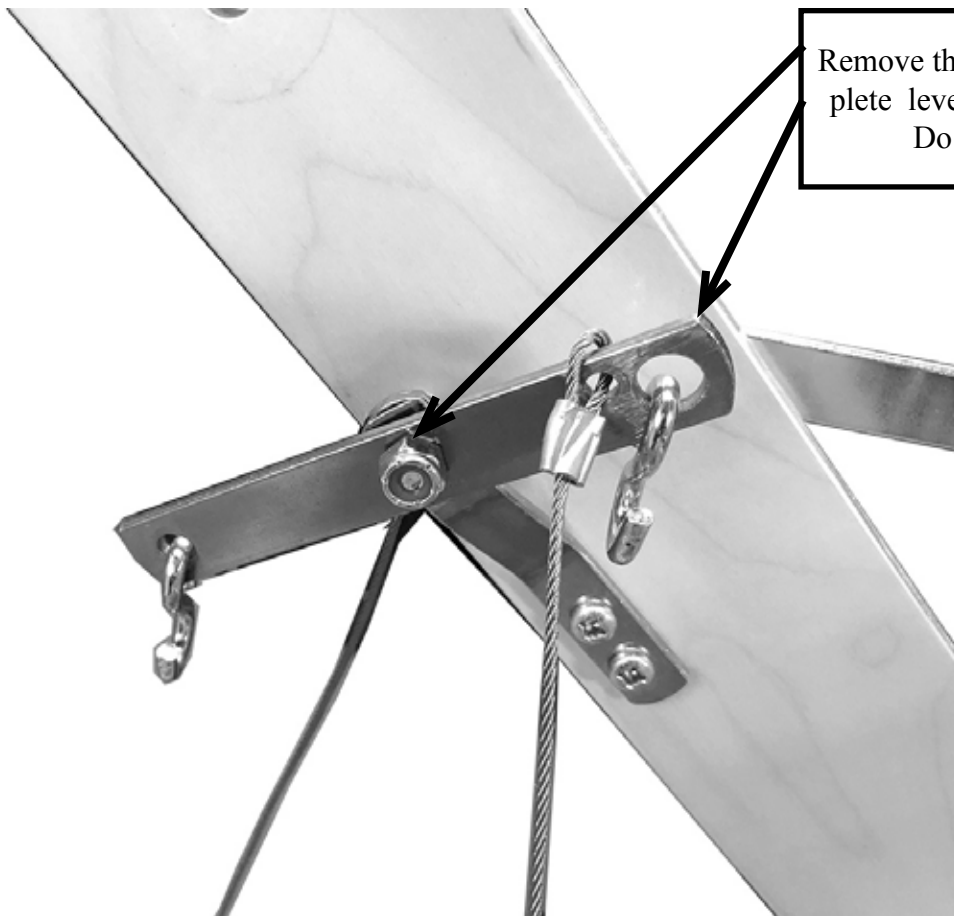

Remove the autolock nut and the complete lever and put them in the floor. Do not remove the bolt.

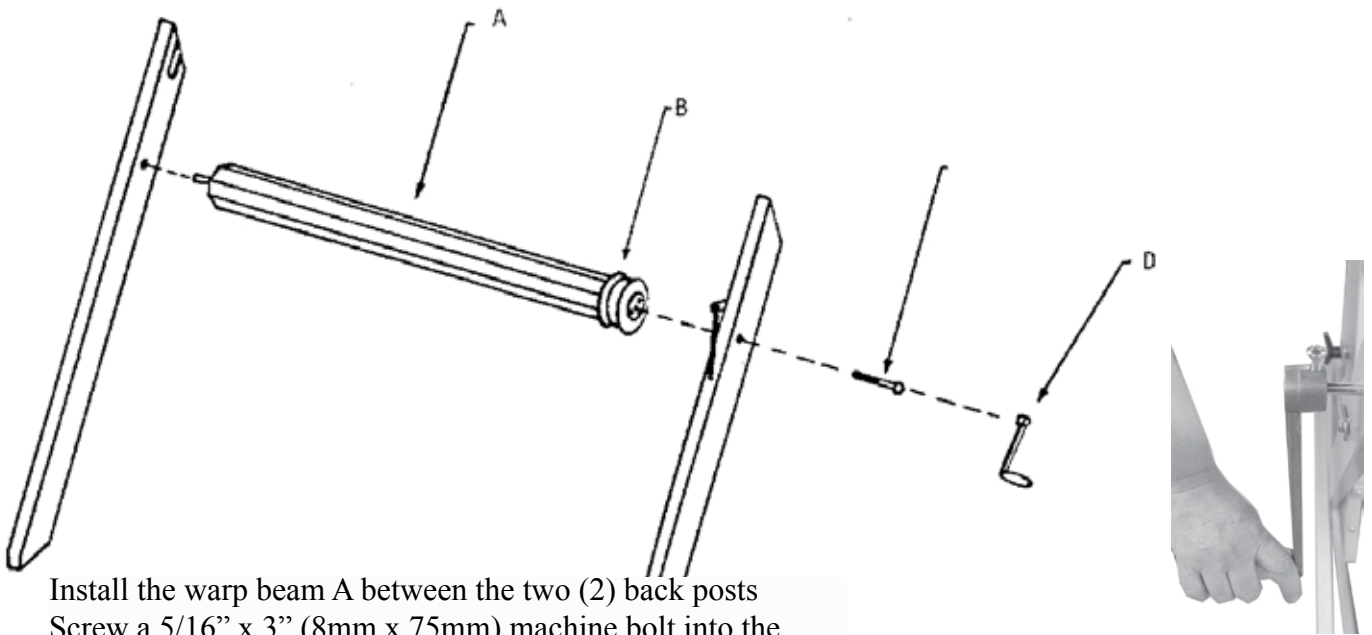

Install the warp beam A between the two (2) back posts
 Screw a 5/16" x 3" (8mm x 75mm) machine bolt into the
 brake drum B.
 Use the crank D to tighten the bolt until it is hard to turn.

Turn 4 times the brake cables (with the
 lever).
 Place the first row next to the back post
 and the last row inside the loom.

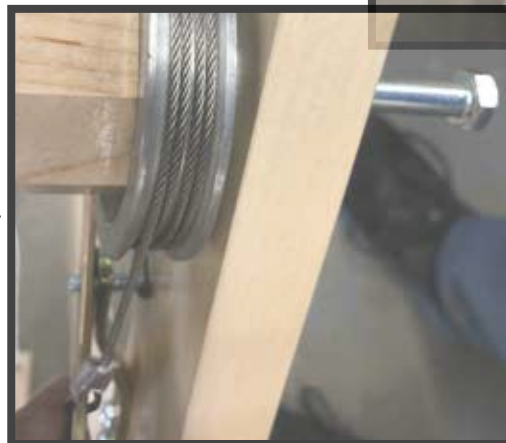
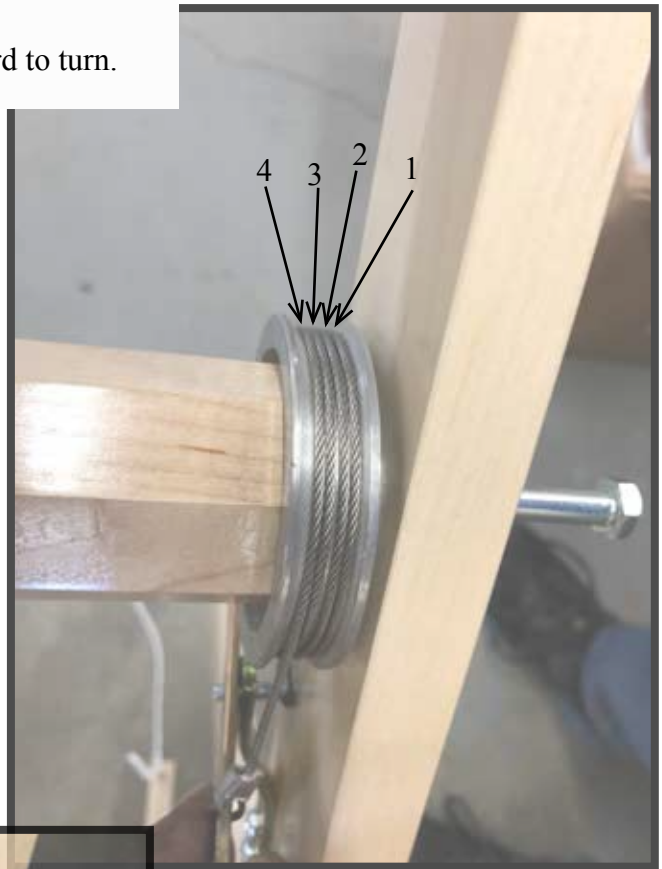

The brake cable should
 now be in the groove of
 the brake drum and the 4
 rows have to be side by
 side.

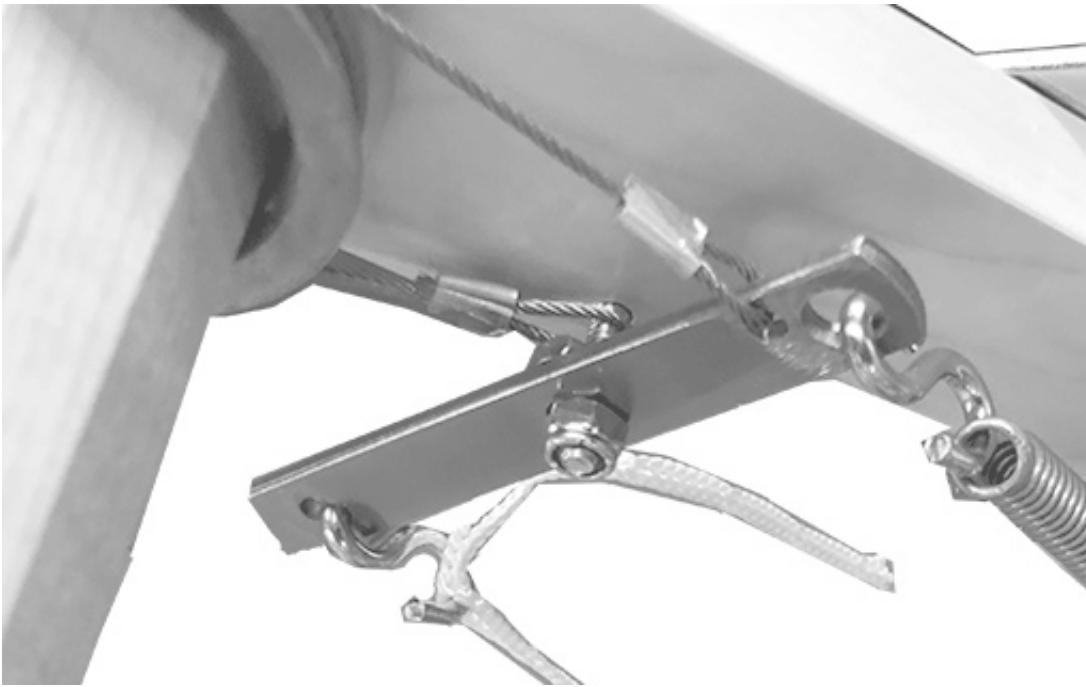

Screw the autolock nut .
Do not overtight so the lever is moving freely.

Attach the spring to the front S-hook and the loop cord to the main castle screw at the black mark.

The tension on the spring should be high enough to lock the warp beam while weaving.

The warp beam should turn with some friction clockwise (while standing at the right side of the loom near the brake system) and this is the warping rotation. However, you should always release or reduce the tension on the brake cable by adjusting the length of the loop cord when warping.

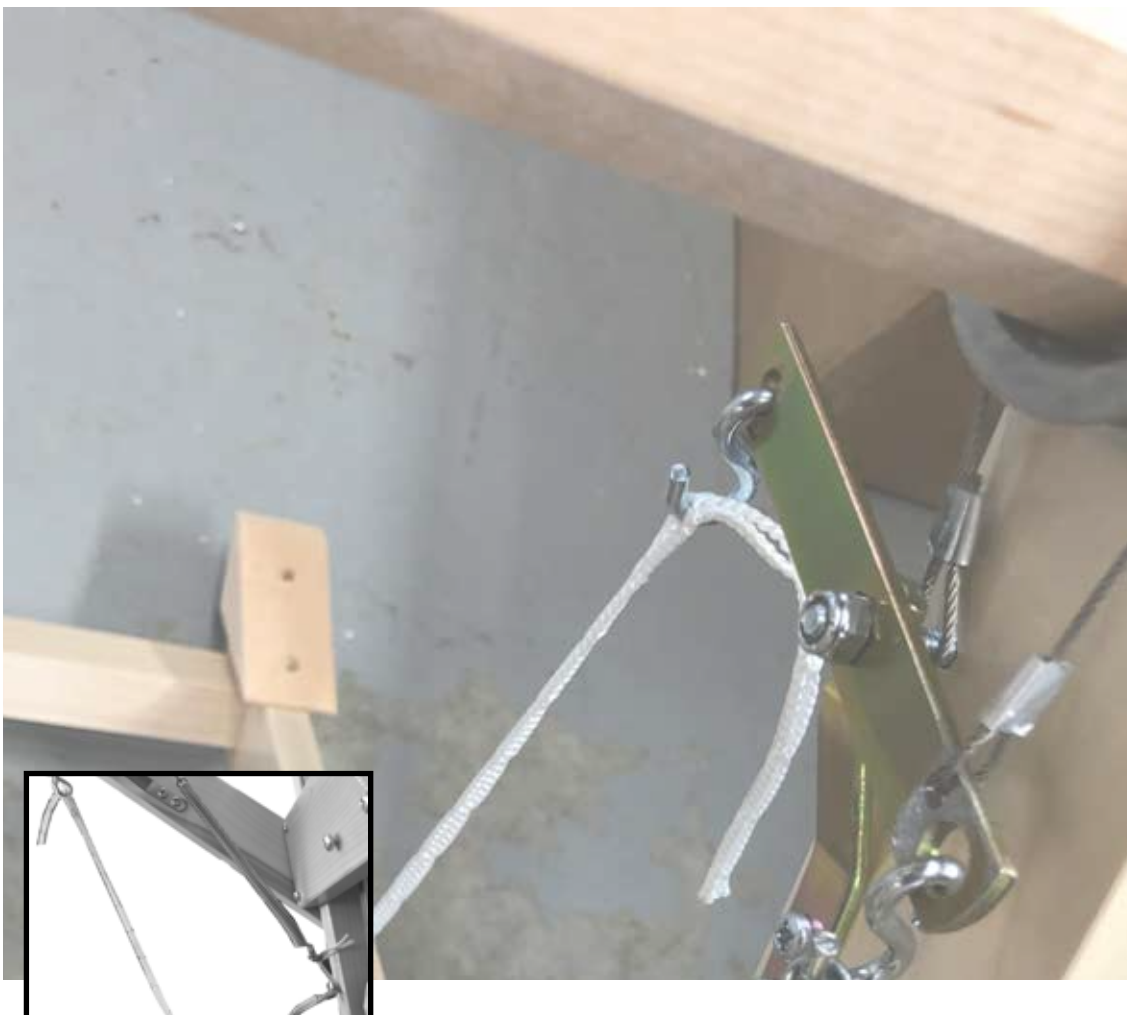

Connect the back lever “S” hook to the brake treadle.

Use the black mark as a starting point.

To advance the fabric when weaving, depress the brake treadle just enough to release the warp beam.

Depressing the brake treadle too far may cause the brake circle to come off the brake drum or be a mix-up in the brake drum.

Is it recommended to unhook the spring when winding on the warp (as well as folding the loom)

Install the thread beam (29½") A using round-headed screws No. 14, 1½". Install the lower cross-member B (30½") in back of the loom with round-headed screws No. 14, 2".

For installation with the wheels, use 2 flat headed screw #14 x 3 ½".

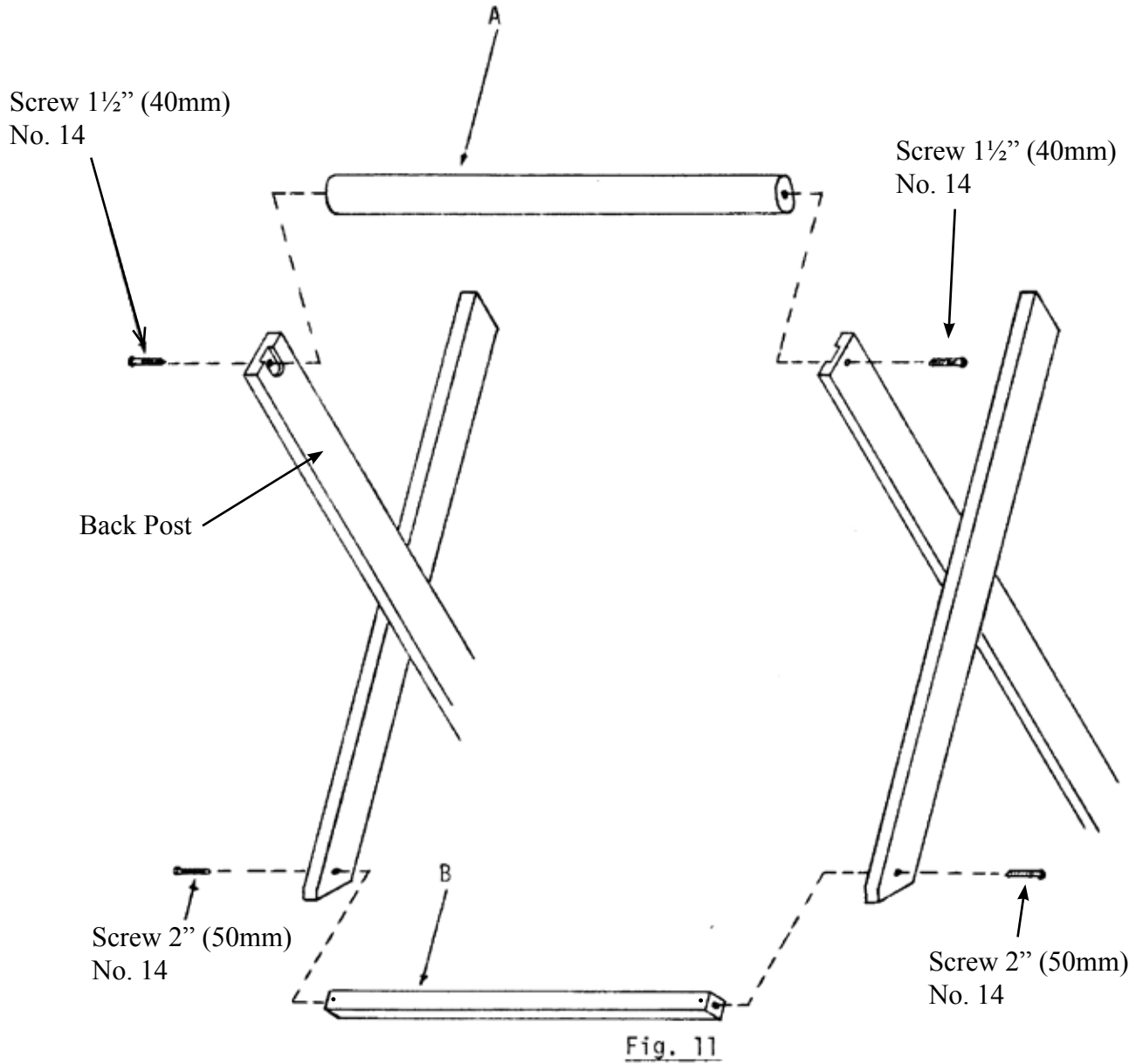

Fix each of the two (2) batten swords A inside the front legs with a 5/16" x 2" (8mm x 50mm) carriage bolt. Place a steel washer between the sword and the leg. With a hammer, hit on the head of the bolt until the square inside part is in the wood. Put a washer inside and lock it with the nylon auto lock nut 5/16" (8mm) without overtightening it. The swords must move freely.

Fix the batten sley B with two 2" (50mm) round-headed screws No. 14.

Fix the batten handtree C with two 1/4" x 2 3/4" (6mm x 70mm) carriage bolts, two steel washers 1/4" and two wing nuts 1/4" (Fig. 12A).

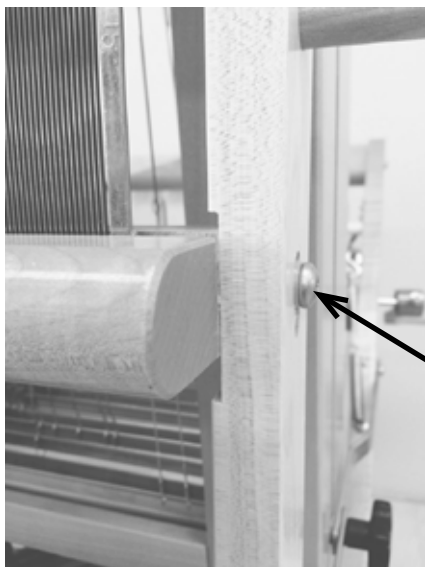
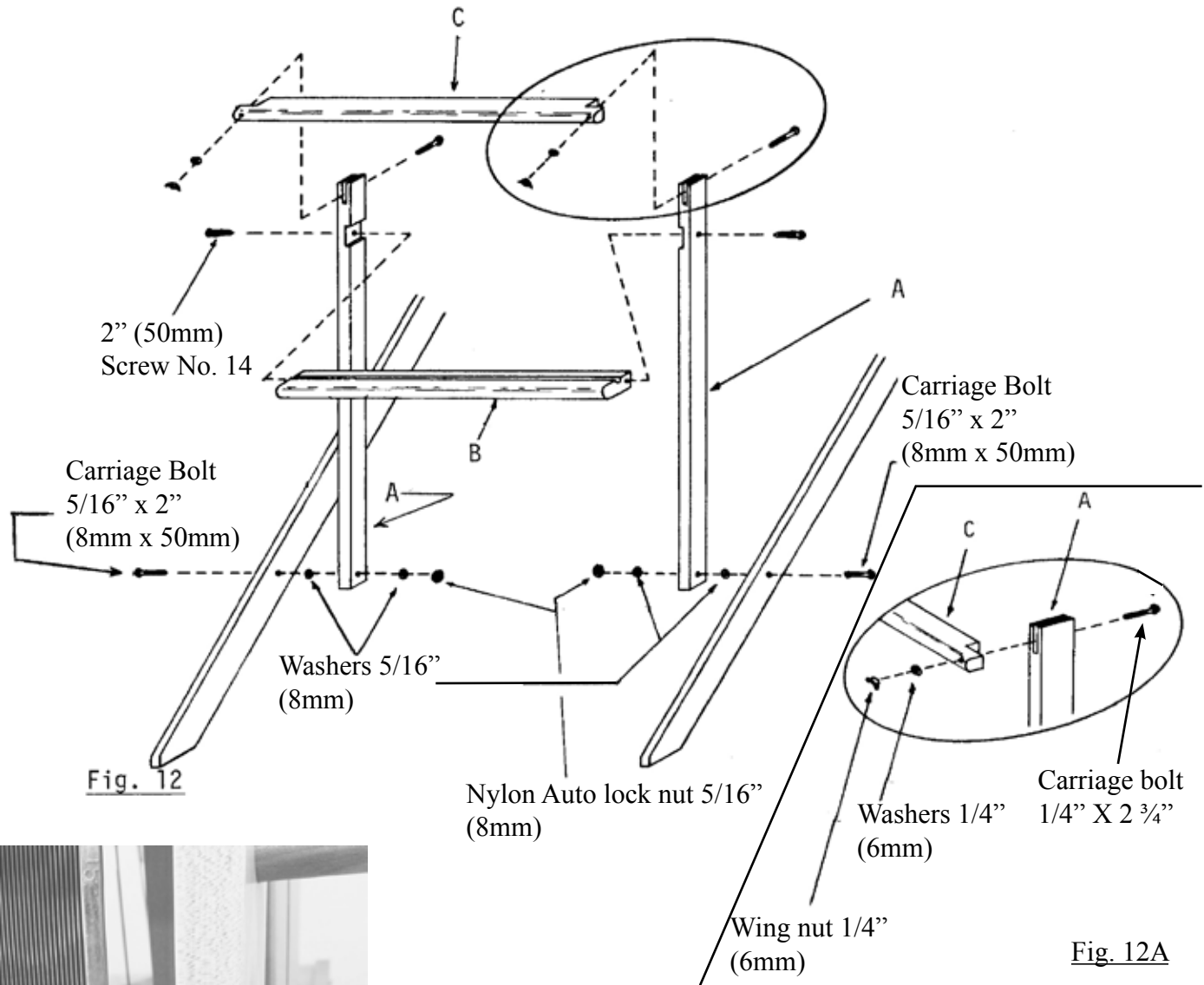

Round-Headed screws #14, 2" and a plastic washer 3/16"

NOTE: The beater height is now adjustable. The middle of the groove is a good place to start with.

Place the reed A between the batten handtree B and the batten sley C, and lower the batten handtree.
Tighten the wing nuts.

Using a hammer, insert a batten stopper D (round piece of wood) into each of the two (2) swords E.

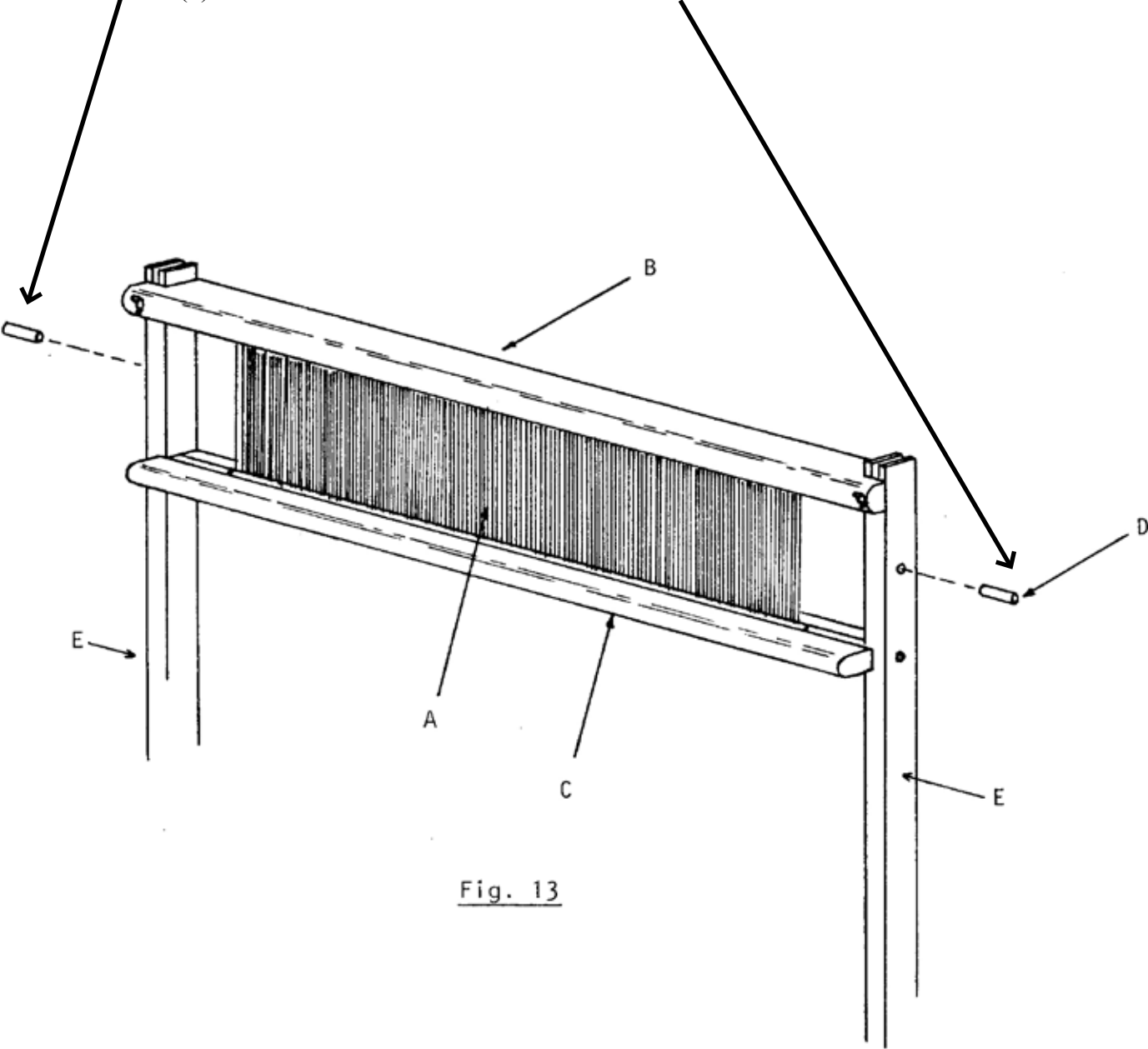

Fig. 13

Install the breast beam A with two round-headed screws 1½" (40mm) No. 14.
Make sure that the hole for the eyescrew is on the right side, more instruction on next page.

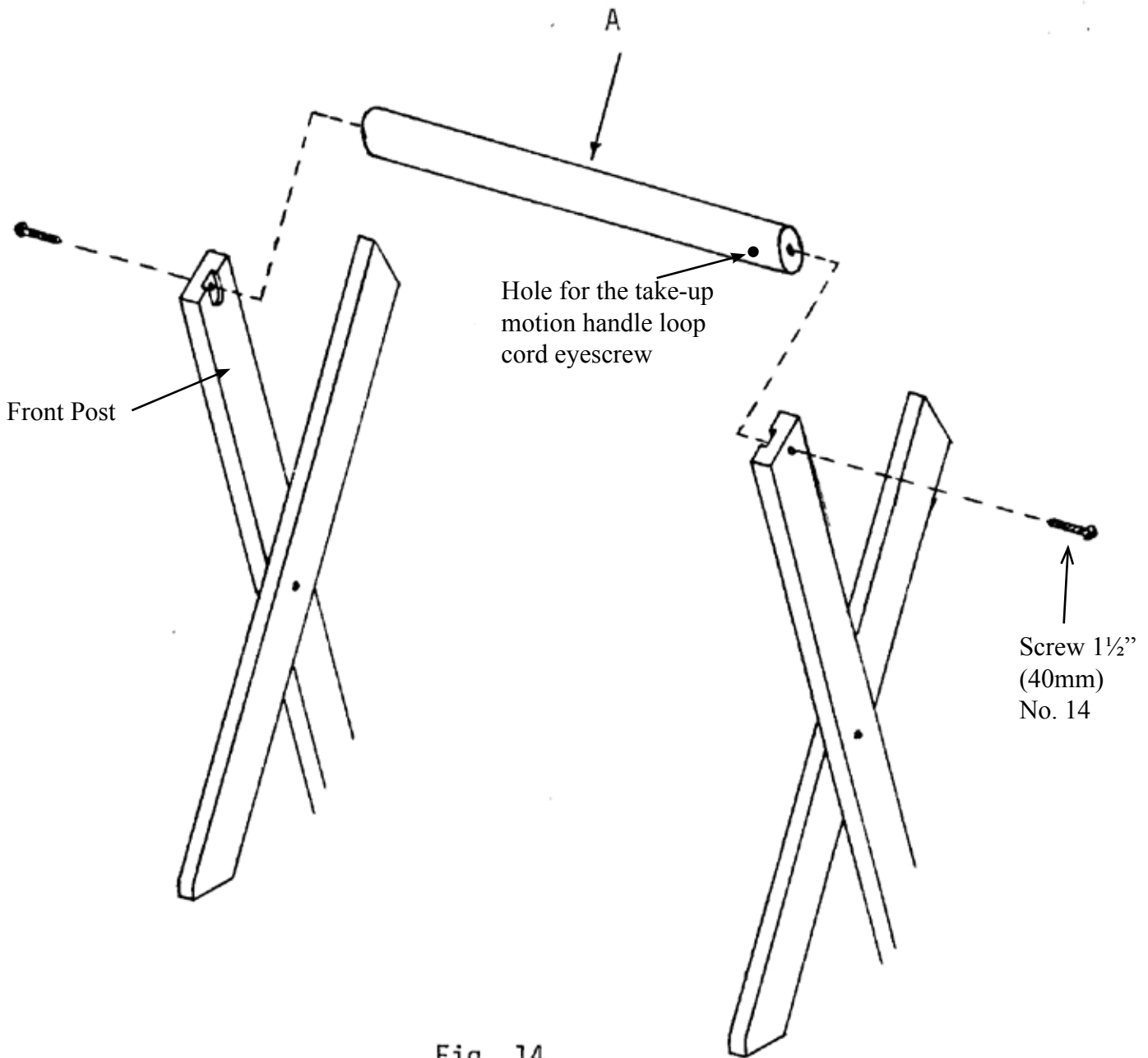
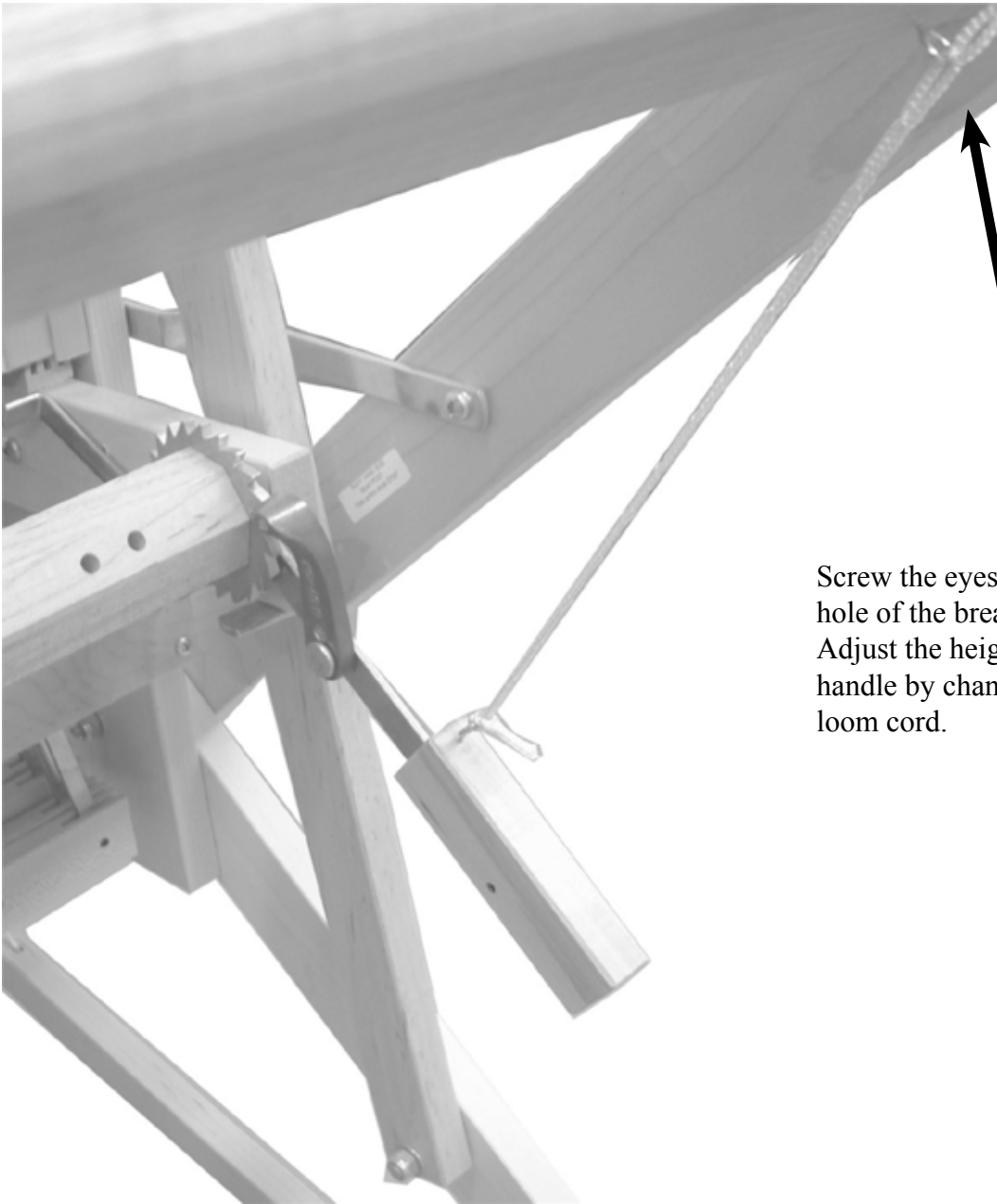
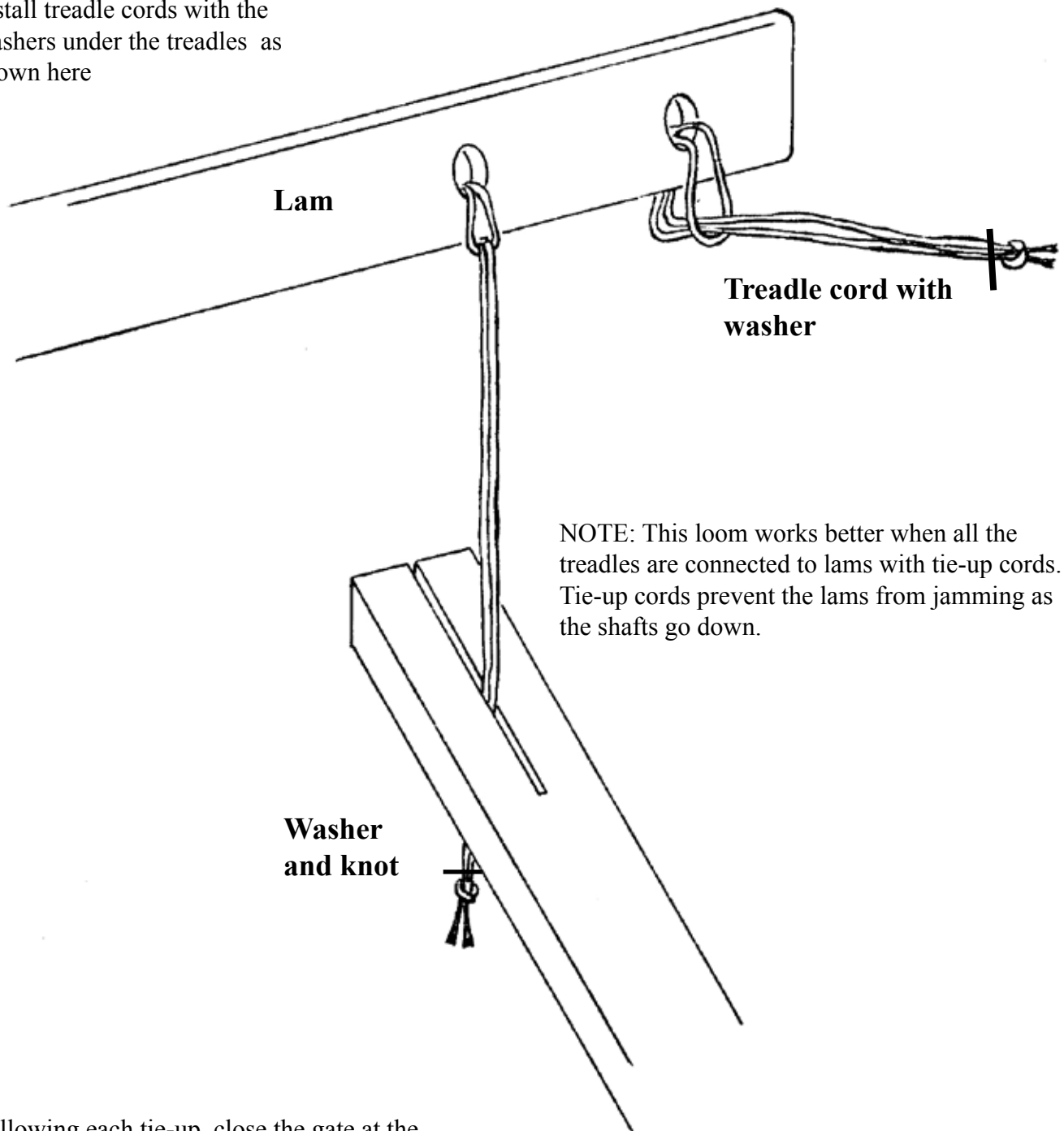

Fig. 14



Screw the eyescrew in to the pre-drilled hole of the breast beam.
Adjust the height of the take-up motion handle by changing the length of the loom cord.

Install treadle cords with the washers under the treadles as shown here



Following each tie-up, close the gate at the end of each treadle.

Note that if the gate on a treadle is hard to open/close, it may be necessary to slide the Texsolv Treadle Spring Cord a few inches along the treadle closer to the front of the loom to make opening/closing the gate easier.

Once the gate is closed the Treadle Spring Cord can be re-positioned back closer to the gate."

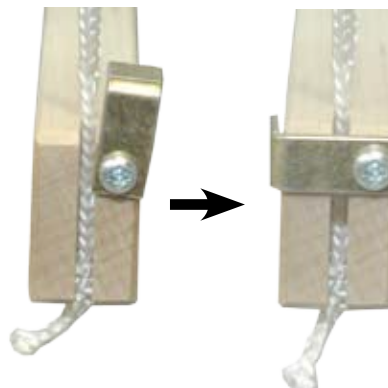

SPRING KIT

When more than 6 treadles are connected to the lams, the weight of the treadles can lift the shaft frames up or make the movement down very difficult.

To correct this you will have to install springs that will support the weight of each treadle.

Use the screws of the back jack board to install the springs

Make a loop cord knot so the length of the spring with the loop cord will hold the weight of the treadle.

Slide the loop cord end (knot) under each treadle.

It is preferable to always have a small amount of tension on the treadle spring when the treadle is in the up position.

Install in the back of the jack box the round headed screws (#12, 3/4") to anchor the loop cord. Make sure that each screw align with the treadle.

Used the drill 11/64" to make the pre-drill holes.

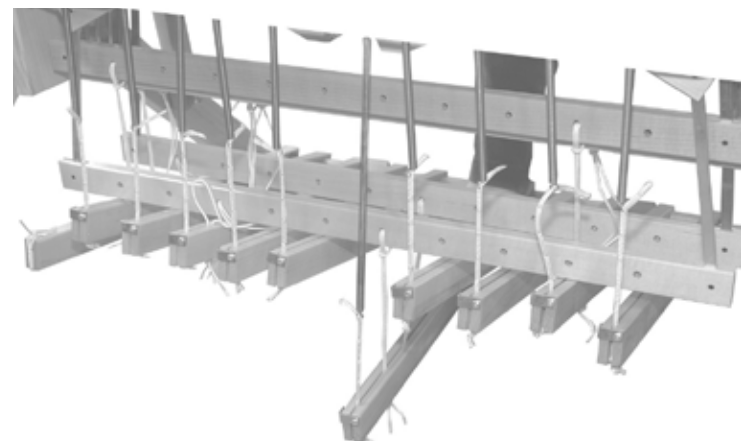
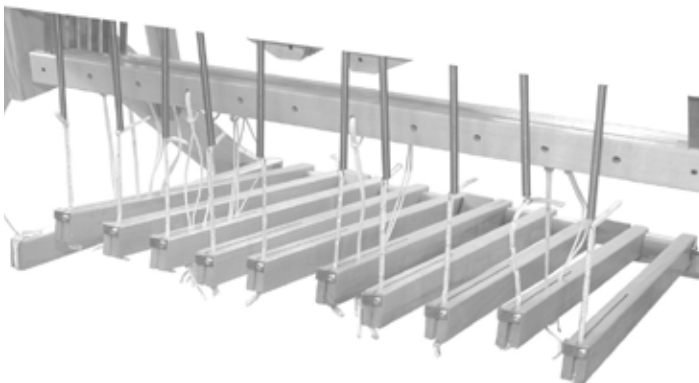
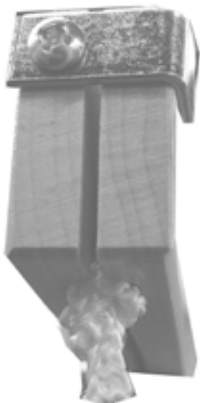
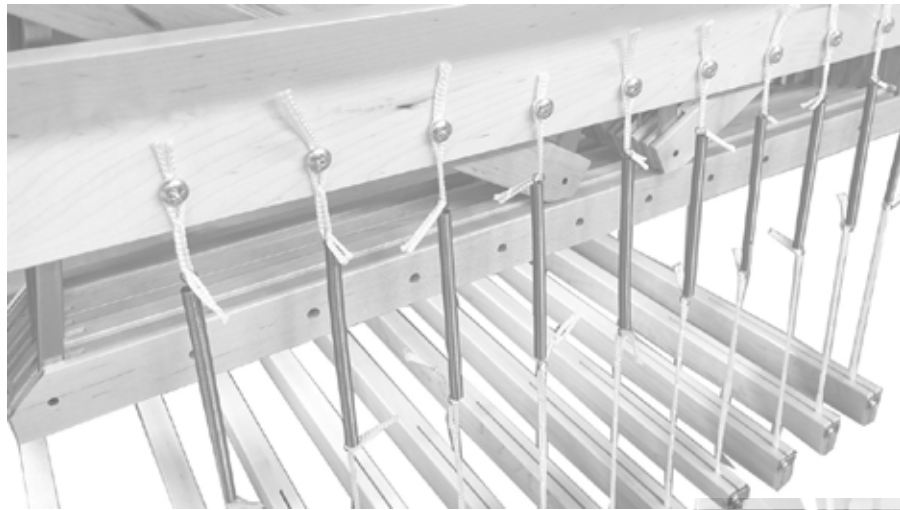

BEAMING

On this loom, beam sticks, metal rods and cords have to be installed in place of the usual apron.

Thread a 10 yard (9.2m) nylon cord through the third set of holes of the warp beam.

Then thread the two cord ends through the corresponding holes of the beam stick

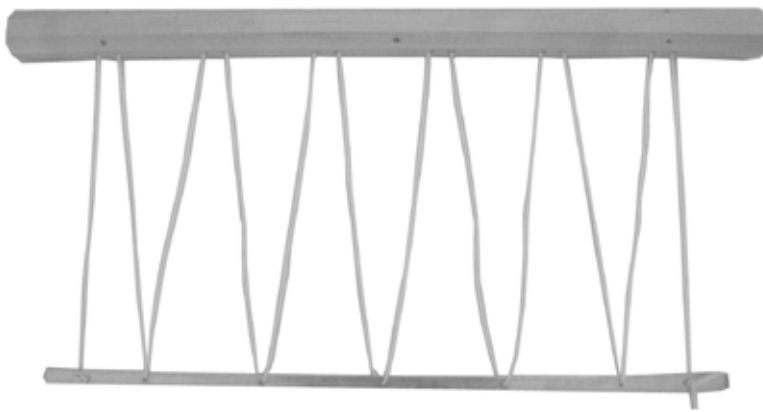
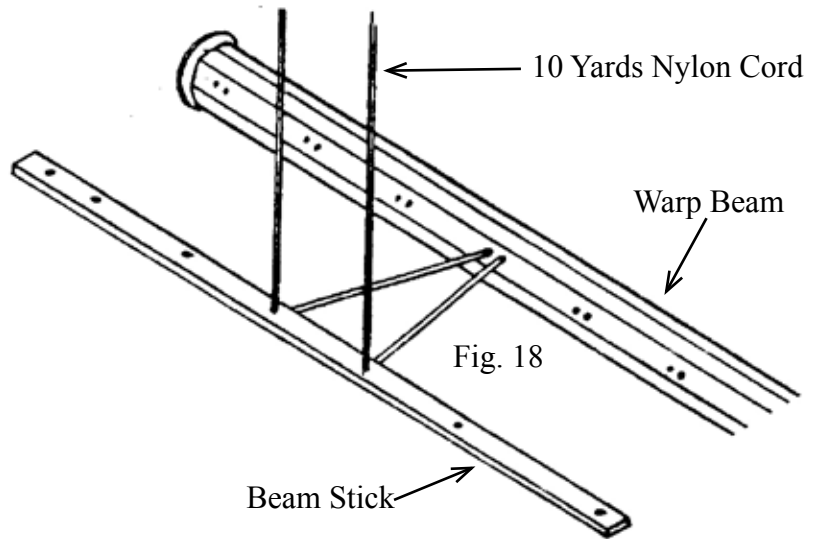

Continue threading the cord through the warp beam and the beam stick.

Knot the cord at each end of the beam stick.

Adjust the cord so that the tension and the length are the same for the whole width of the loom.

Fig. 19

Cut the 5 yard (4.5m) cord in half. Use one half of the cord to lace the beam stick to the warp rod.

Repeat the same operation for the cloth beam.

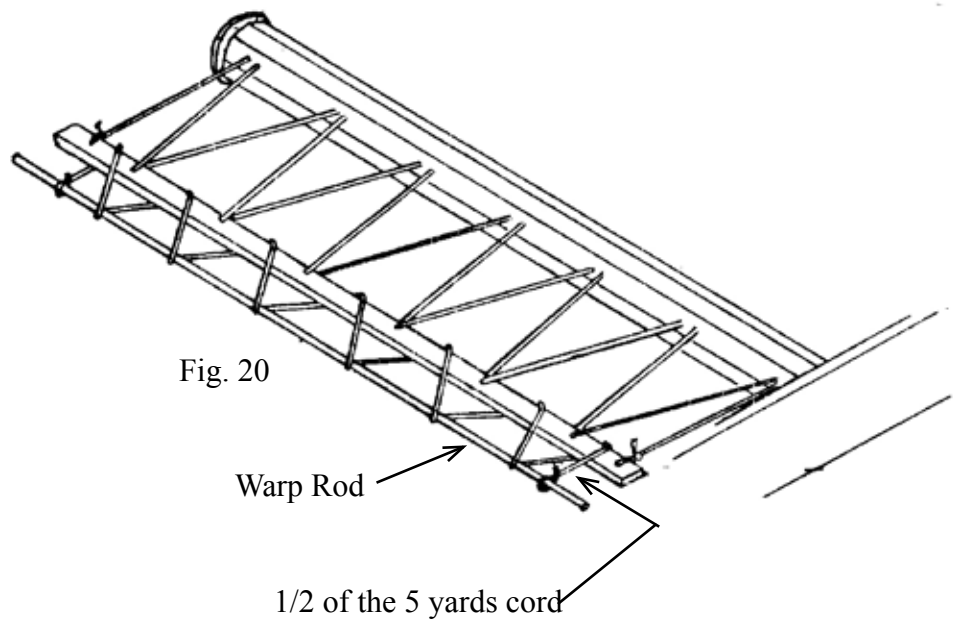

Fig. 20

Warp Rod

1/2 of the 5 yards cord

To install the heddles you can just bend the heddle supports .

To remove the shaft frames you first have to unscrew the top nut of the jack pin. It is important to leave the bottom nut as it is.

Then pull up the shaft frame from the castle.

We strongly recommend that you have those nuts installed at all times.

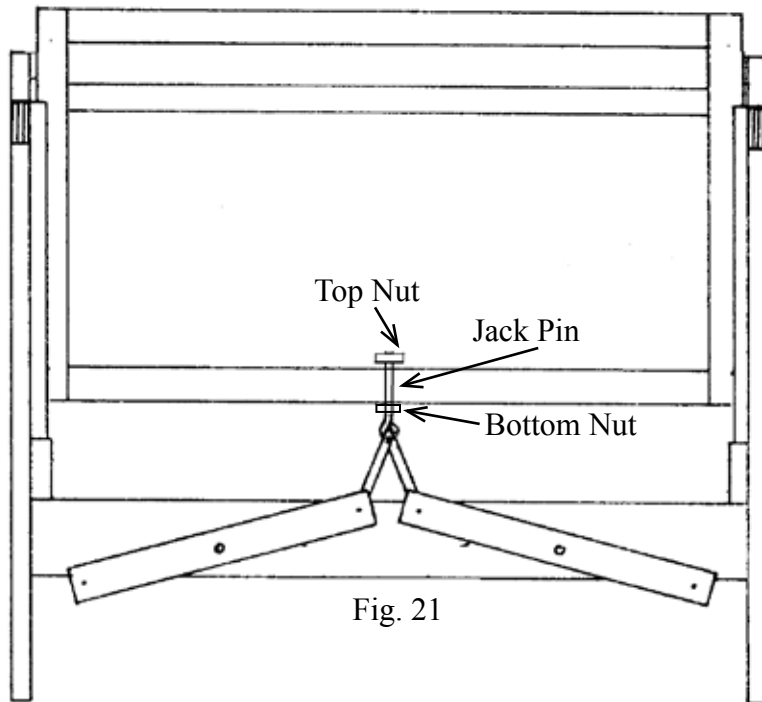

Fig. 21

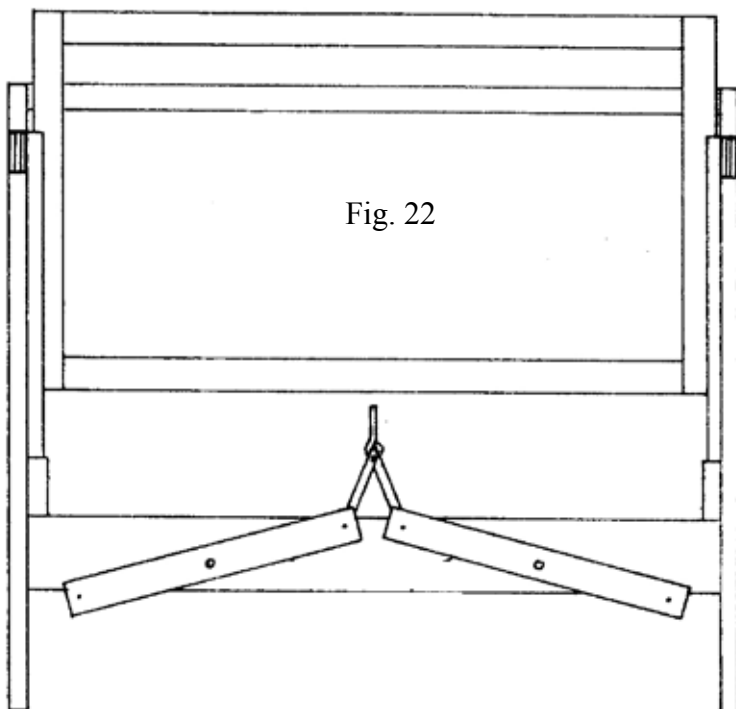

Fig. 22

TO INSTALL HEDDLES:

Disconnect the center of both heddle supports of a shaft frame and take it out of the end frame by bending it.

For more information, see the book supplied with the loom "Warp & Weave".

Warp beam advance control system

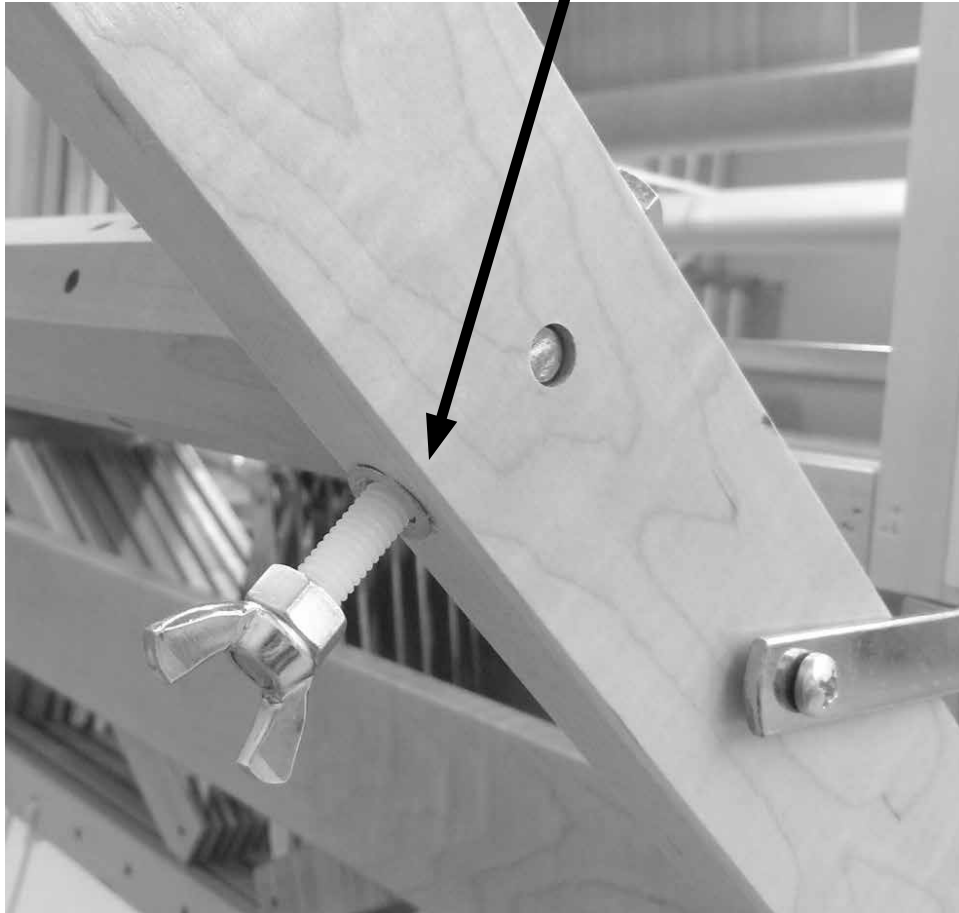

Install the Warp beam advance control system.

This system will eliminate excessive warp yarn advance when releasing the brake system at cloth take-up.

This friction system is adjustable and **have to be released when winding the warp on.**

Just screw the wing nut with nylon bolt in the pre-install metal indert of the left back post.

Screw in to Increase the friction or unscrew it to release.



To fold the loom, Disconnect the friction brake loop cord from the screw (S), release the tension by pressing the brake treadle, then loosen the plastic handles on each side of the loom and pull these upward. Tighten the handles. The loom can fold even with fabric on it.

IMPORTANT NOTE: Be careful when closing and opening the loom. To avoid damage and injuries, NEVER completely remove the plastic handle.

MAINTENANCE:

In order to get the maximum efficiency from your loom, we recommend you periodically spray a lubricant (silicone) on the plastic slides on each side of the loom.

We at Leclerc encourage Weaver feedback on this and all our products. Please send your comments to Leclerc Loom Inc.

HAPPY WEAVING