

Leclerc Looms

Since 1876



1573 Savoie
C. P. 4 Plessisville, Qc.
G6L 2Y6
TEL: 819-362-7207
FAX: 819-362-2045
www.leclerclooms.com
info@leclerclooms.com

DIANA 16 SHAFT COMPUTER-DOBBY

2120-1624



Loom Prepared by: _____

Inspected by: _____

Date: _____

Main castle assembly

Parts list

To assemble this loom, a minimum of 2 people are needed



Flat head screw:
8 X 1 1/4"



8 X Nylon Spacer



Left upright



Right upright



Lower crossmembers



Head section
Do not remove the saran wrap



Front beam section



Back beam section



Using 4 flat head screws no 8 X 1/4", affix the front and back crossmembers to the uprights. Make sure to screw to the predrill holes of the uprights.



The right hand side uprights have a metal lever and a white nylon part in the front.

Right hand side uprights



Remove the 2 wood parts with X marks and discard them.

Very important to handle with high care.
Do not remove the saran wrap

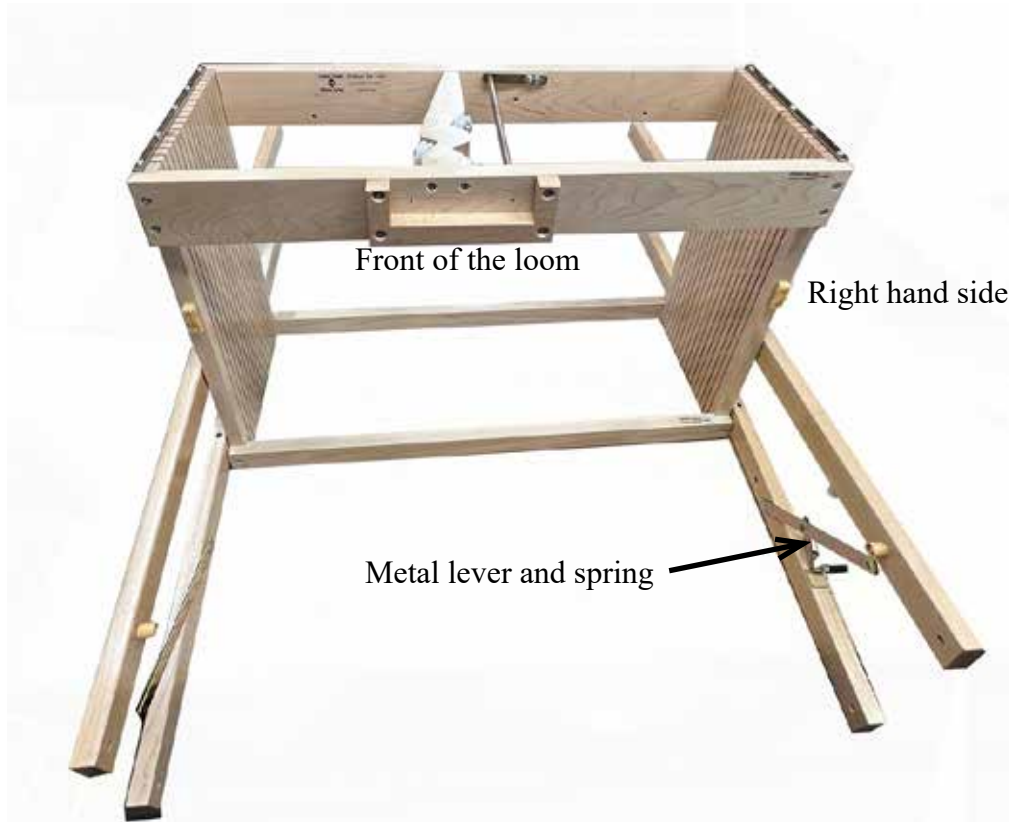

Using 4 flat head screws no 8 X 1¼", affix the head section the uprights.
Make sure to screw to the predrill holes of the uprights.

Remove the saran wrap.

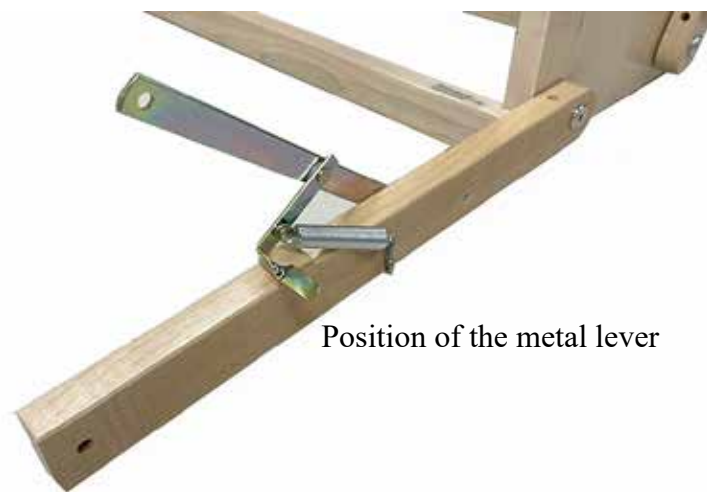

Affix the front and back posts assembly using 8 X 1 1/4" bolt and 8 X nylon spacer. A nylon spacer need to be placed between the posts and the lateral cross-members.

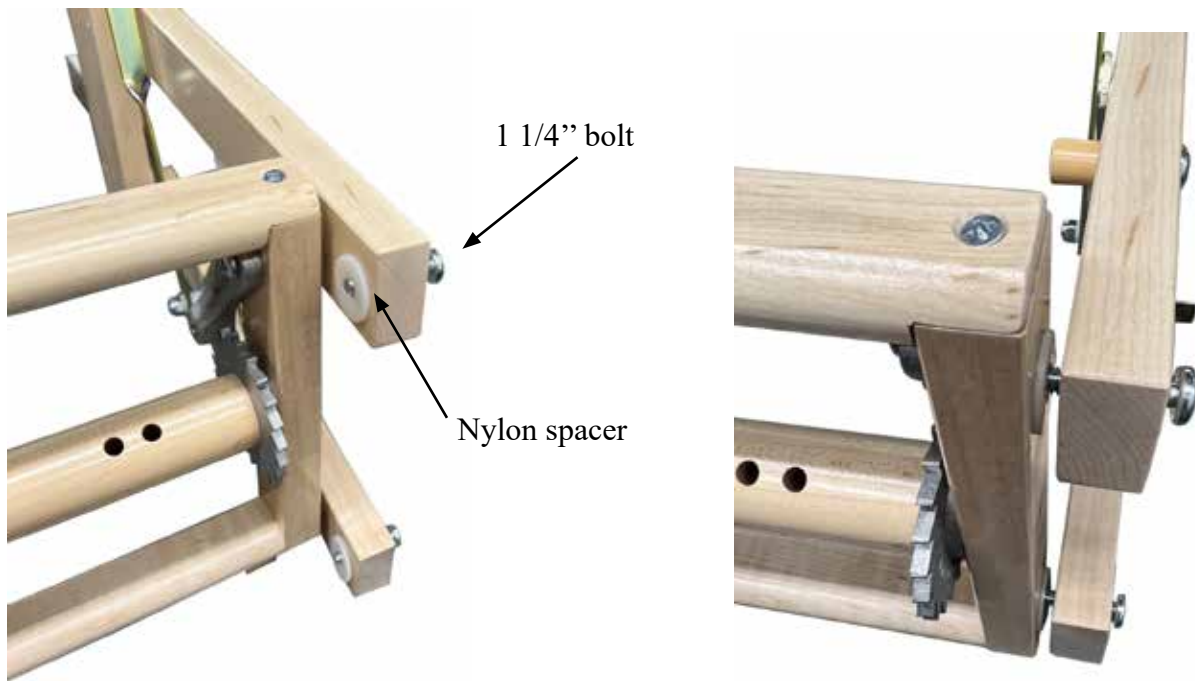

Affix the 2 front hooks (1) to the front cross-member using the plastic nub and the screwdriver to hold the bolts. Before attaching the right side hook, make sure the brake lever and spring are pointed toward the front of the loom (closest to the weaver) as shown.

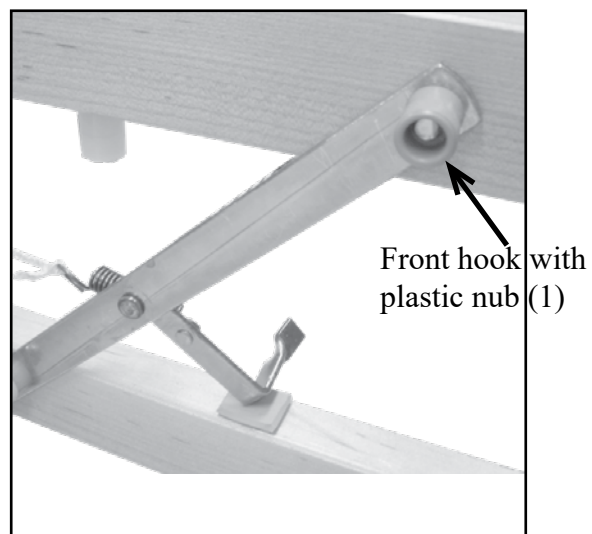

The Loom shipping container includes the following:

**LOOM HEAD SECTION
ASSEMBLED AND FOLDED**

Note: The shaft frames with heddles supports are in a different box.



**SHAFT SELECTOR UNIT
WITH SOLENOIDS UNIT**

Note in French for Leclerc:

- Avec corde à maillons pour couteau.
- Poulie de tête avec guide.
- 3 guides de corde pour planche du centre



TREADLE SET

Note in French for Leclerc:
Battent complètement assemblé



**BEATER ASSEMBLED WITH REED
12 DPI --- SS---**

2 BEATER SUPPORT BOARDS



1 PULLEY



2x Shelves (S)

16 round head screws #6 x 5/8"
 4 machine bolts 5/16" x 1 1/2"
 4 wing nuts 5/16"
 4 Iron shelves supports

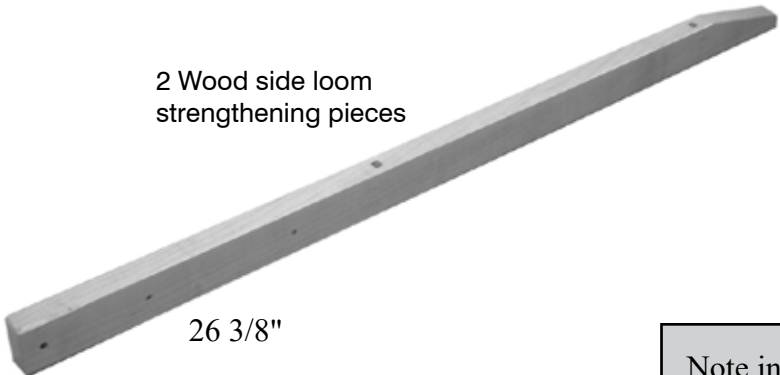

Note in French for Leclerc:
 Faire les 4 trous pour les croisées de métal

4 Uprights (M)
 4 Montants (M)



1 Right and 1 left base (B)

1 Base droite et 1 base gauche (B)

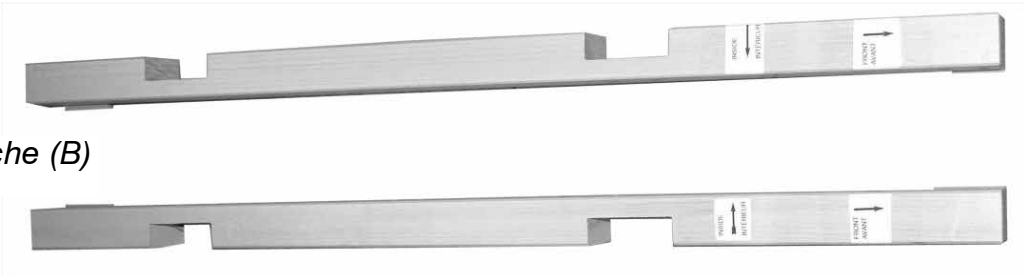

1 Lower cross-members Back with 2 holes
 1 Traverses du bas "arrière"

1 Lower cross-members "Front"
 1 Traverses du bas "avant"

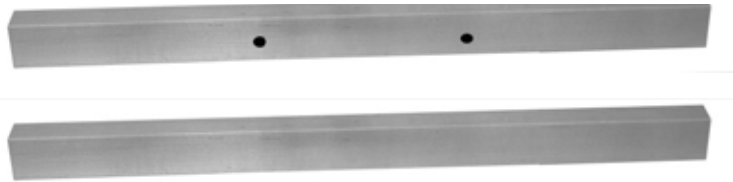

4x wood spacers 1 1/2", 4x machine bolts 2 1/2" and 4x metal parts (F)

2 Upper Cross-members (T2)



IMPORTANT:
This Interface box is a new version and will work only with the 24s or leclerc II software driver.

1 Interface box with connecting cables.



1 Sabrent USB to serial cable adapter

1 USB KEY

WITH INSTRUCTION, USB DRIVERS AND VIDEO. PLEASE ALWAYS REFER TO PAPER INSTRUCTION IF DIFFERENT



2 CRANK HANDLES (LONG)



1000 INSERTED EYE HEDDLES (OR TEXSOLV)



2 Wood piece

Before putting the loom in his normal position, put two wood piece under the shaft frames.



3 SQUARE HEAD SCREWDRIVERS (green, black & red)



1 Adjustable Wrench



1 BOAT SHUTTLE 6122-1000



1 REED HOOK 6141-9000 (8 5/8")



2 METAL LEASE STICKS



2 METAL WARP RODS



10 x 18" (46cm) LOOP CORDS FOR LASHING



1 WARP & WEAVE BOOK



6 Carriage bolts 1/4" x 3 1/4"

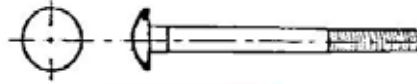

8 Bolts 1/4" x 1 3/4"



16 Washers 1/4"



20 Nylon auto lock nuts 1/4"



2 LOOP CORD 47" FOR TREADLE CONTROL



ROUND HEAD SCREWS

2x #6 - 5/8"

8x #14 - 2 1/2"

2x #14 - 2" (Treadle blocks)

4x #8 - 1 1/4"

2x #12 - 1 1/2"



Note in French for Leclerc:

La corde de la pédale de droite reste sur le métier.

2x White nylon spacers + 2 white plastic washer for the beater



1x Friction brake wing nut



4 machine screws L" x 1"

4 flat metal plate 1/8" x 5/8" x 7 7/8"

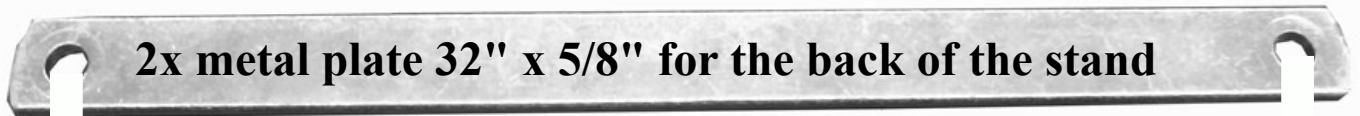

2x metal plate 32" x 5/8" for the back of the stand

Note: Due to minor changes in our shipping process, some parts (ie. screws, bolts, etc.) described in this Part List may not be included separately in the hardware package as they may be already installed on the loom. Please check the Assembly Instruction before reporting a missing part.

Install the shaft frames into the head section.

- 1- Lay the loom on its back side.
- 2- Slide the heddles support of shaft # 16 in the last groove. (see the number in the top right section next to the loop cord. Make sure all the shaft numbers are at the top so they are visible from the front of the loom.

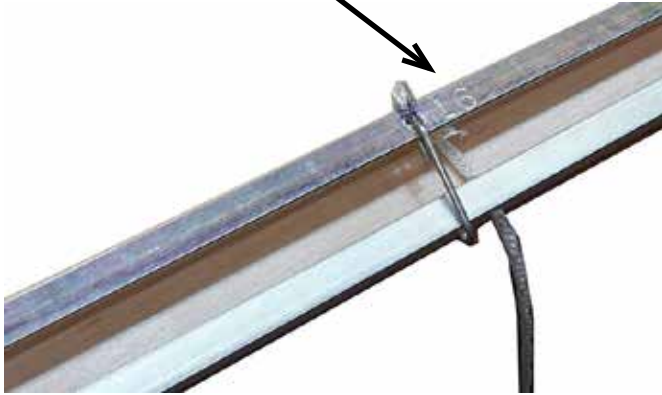

- 3- Before putting the loom in his normal position, the 2 wood piece under the shaft frames.

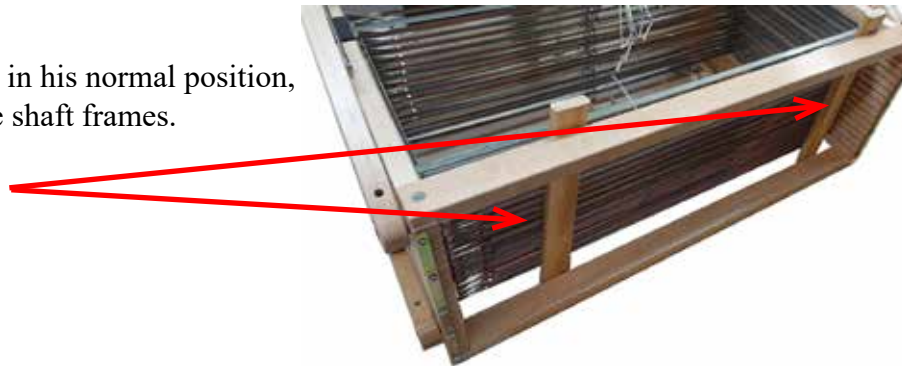

Note: The heddles can be added to the shaft frames after the loom has been assembled by carefully bending the heddles supports out of the castle as described on page 25.

Alternatively, the heddles can also be added to the shafts during Step 2 if done carefully.

If this is being done we recommend that the heddles be moved to the center of the shaft frame to reduce the chance of them coming off to the end. Also gently squeezing the bottom heddles support bar and shaft frame base together while installing the shaft frame helps keep the heddles from moving.

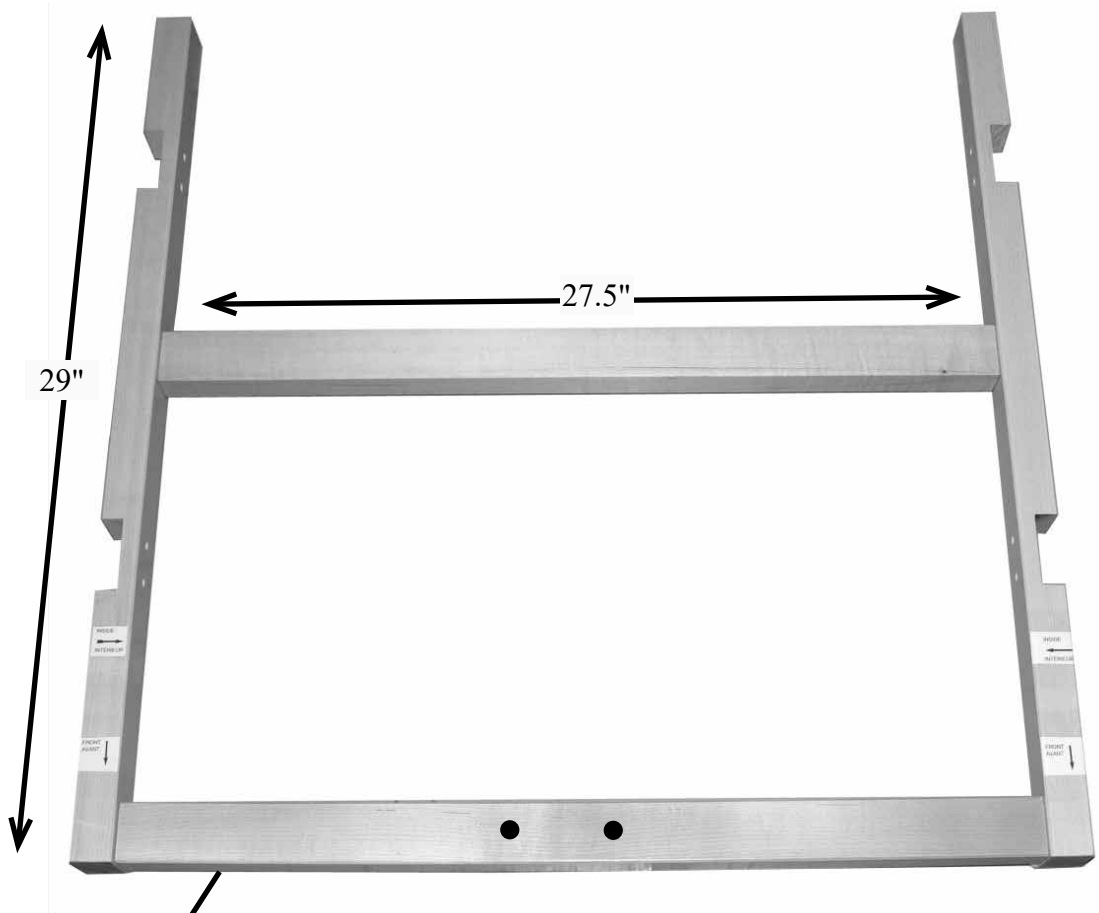

Screw the side base parts to the base cross-members using the 8 round head screws #14, 2½"

The cross-member with the holes for the treadle set should be on the outside as pictured.

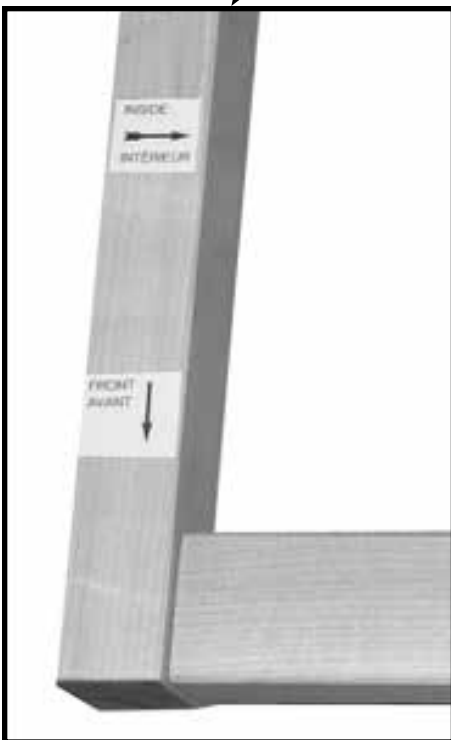

Turn the base stand over (all non-skid pads up) and affix the treadle set using 2 rounded head screws # 14, 2"

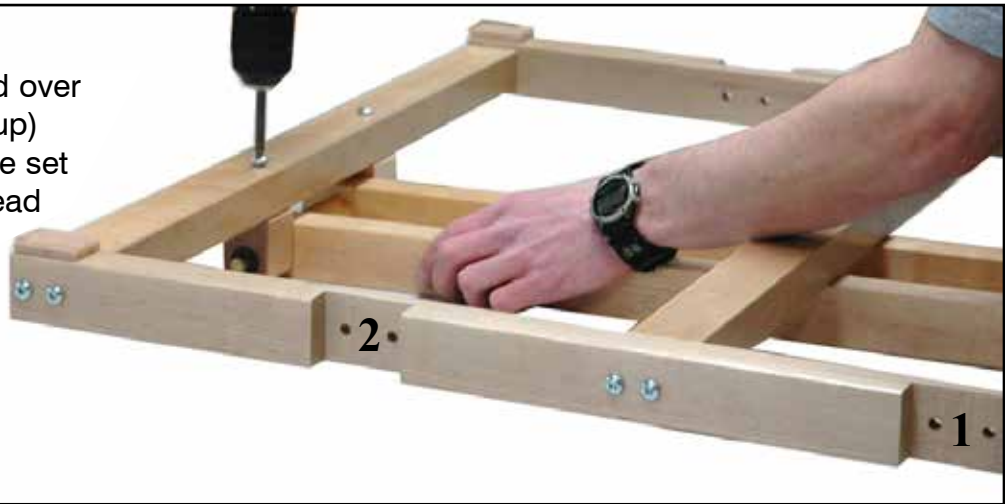

Assemble the 4 uprights to the base using the 8 bolts $\frac{1}{4}$ ", $1\frac{3}{4}$ ", the nylon auto lock nut and the washers.

Two of the uprights will have a pair of screws for mounting the metal cross-bars. These should be positioned in the back slots (2) with the screws facing the back of the loom.



Affix the 2 metal cross-bars using the 4 screws #6, $\frac{5}{8}$ "
Make sure to use the pre-drill holes of the back uprights



Affix the upper cross-members (T2) and at the same time the 4 Iron shelf supports using the 4 machine bolts and wing nuts. Install them to the second holes from the top.

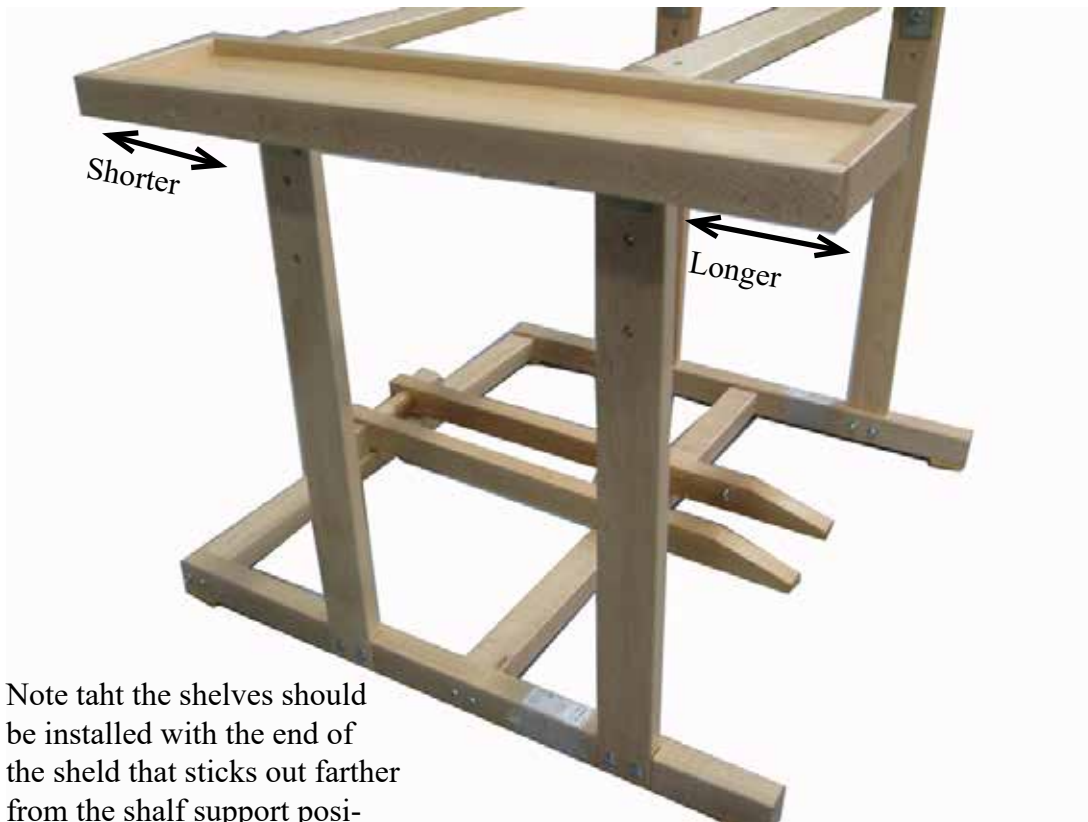

Note taht the shelves should be installed with the end of the sheld that sticks out farther from the shalf support positioned towards the front of the loom

Affix the shelves on their supports with the #6 round head screw.



Affix the 4 wood spacer and the metal attachment to the cross members using 4 machine bolts $\frac{1}{4}$ " x 3"

Unfold the loom on a table and affix the left and right hand side lock metal bars.

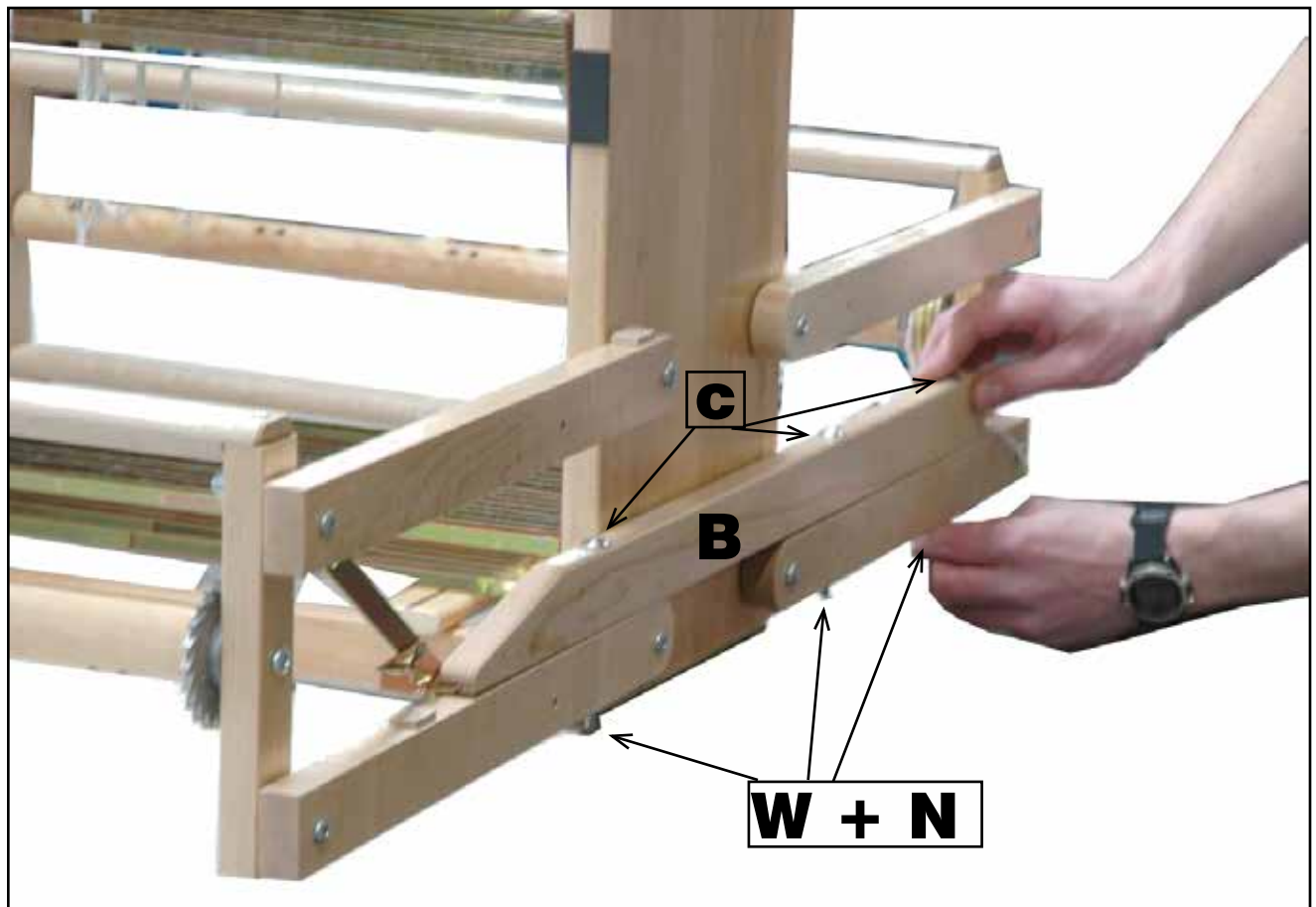
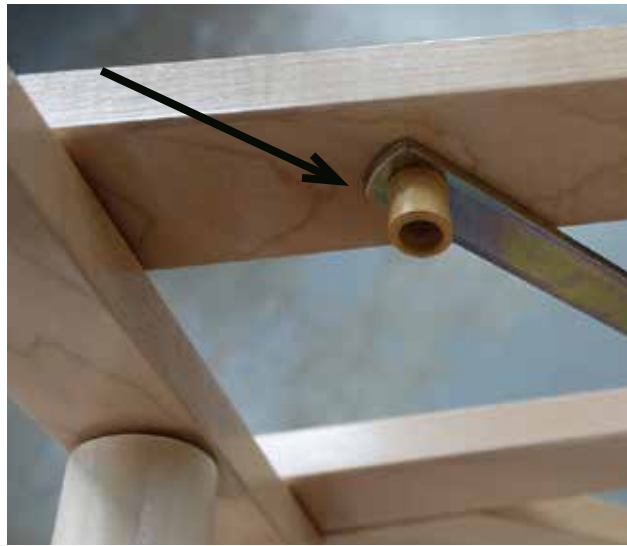

Install the Strengthening wood piece
B (right side) & B1 (left side of the loom)
using:
6 Carriage bolts 1/4" x 3/4" (C)
6 Washers 1/4" (W)
6 Nylon auto lock nuts 1/4" (N)

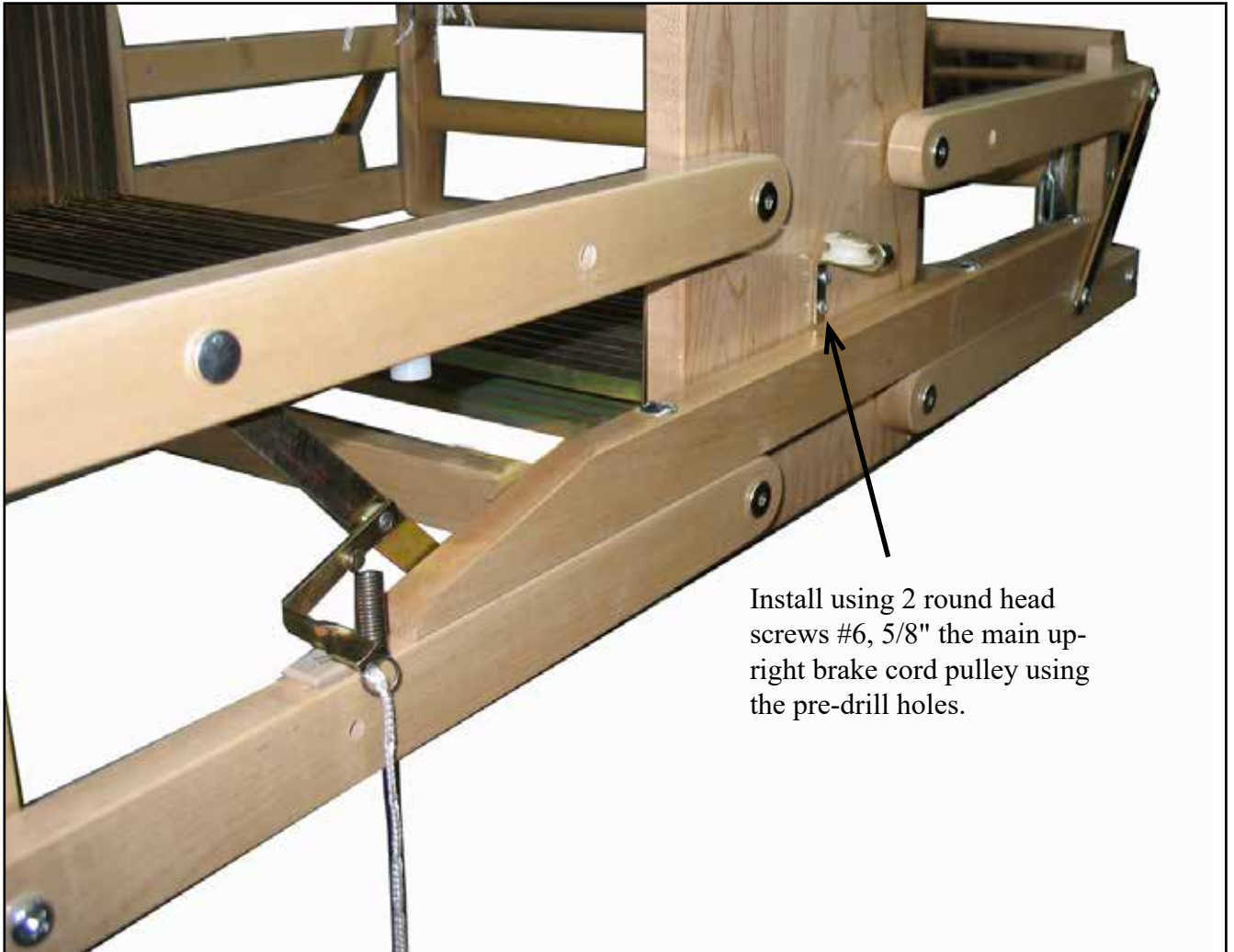

Install using 2 round head screws #6, 5/8" the main upright brake cord pulley using the pre-drill holes.

Friction Brake Dorothy, Voyager and Diana

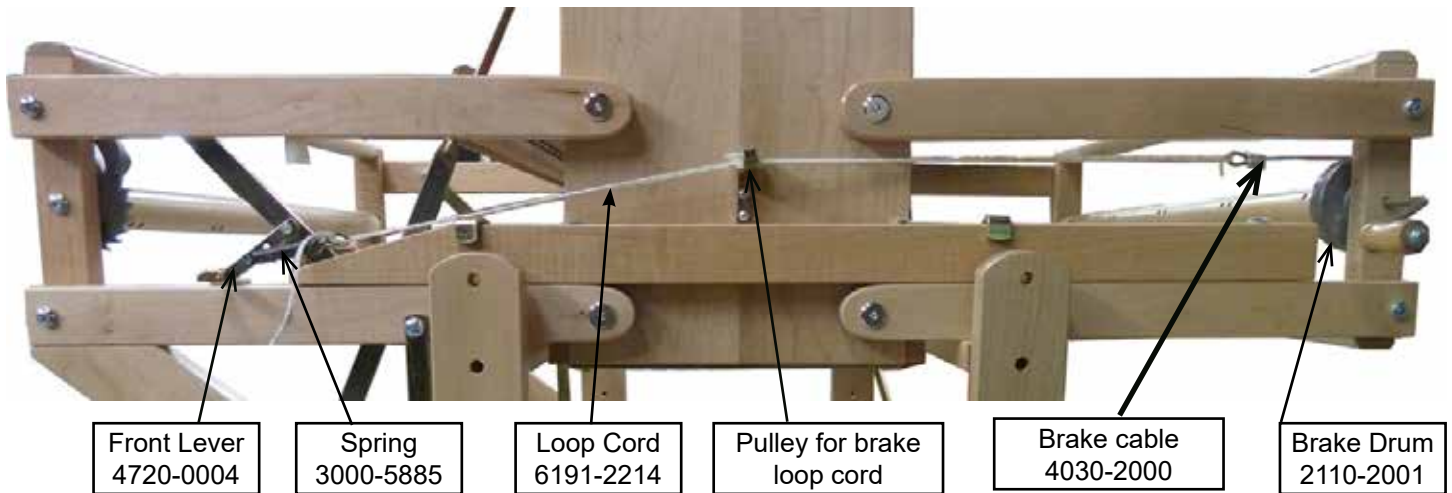

The length of the loop cord has been marked (black mark to the front lever) and tested before shipping. After some time, the loop cord may stretch. You will then have to readjust the tension with the loop cord.

To advance the cloth, pivot the front lever to the back of the loom in order to release the tension on the brake cable. When sufficiently advanced, pivot the lever back to the front to re-establish the tension on the brake. Tighten the warp with the warp beam crank.

Brake assembly with brake cable. Make sure that it is properly in place.

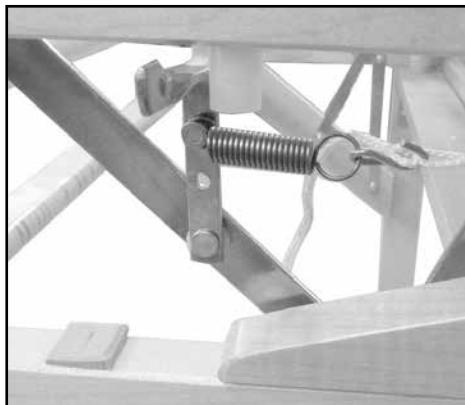
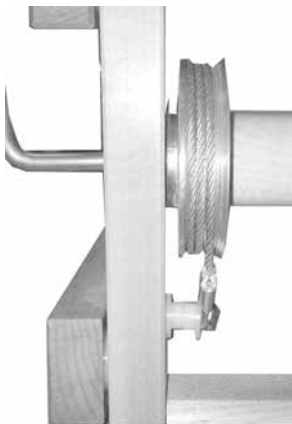

Move it up to release the brake.

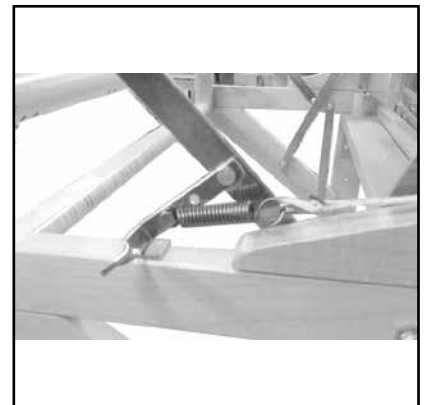

Brake lever closed to tighten the brake cable.





Install the loom over the base stand Affix the 4 metal bracket over the side cross member and screw the machine bolt until it is secure.



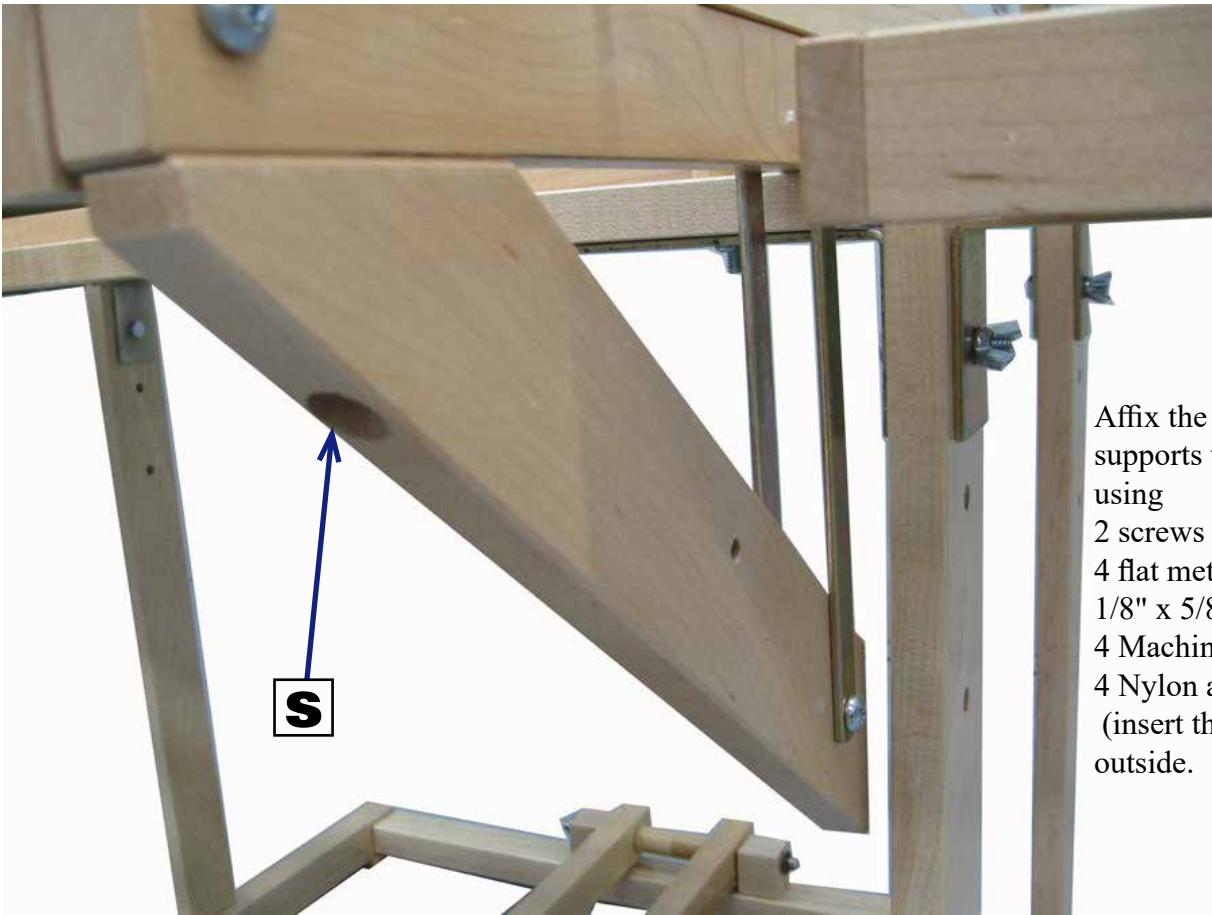

Affix the 2 beater board supports to the base stand using
2 screws (S) #12 1½",
4 flat metal plate
1/8" x 5/8" x 7 7/8"
4 Machine bolts ¼" x 1½"
4 Nylon auto lock nut
(insert the bolt from the outside.



Attach the beater to the loom using:

2 Carriage bolts (N) $\frac{1}{4}$ " x $1\frac{3}{4}$ "

2 Spacers 1" (1 on each side)

2 Nylon washer $\frac{1}{2}$ " (inside)

and 2 Nylon auto lock nuts $\frac{1}{4}$ "

Do not over tighten so the beater can move freely and easily.

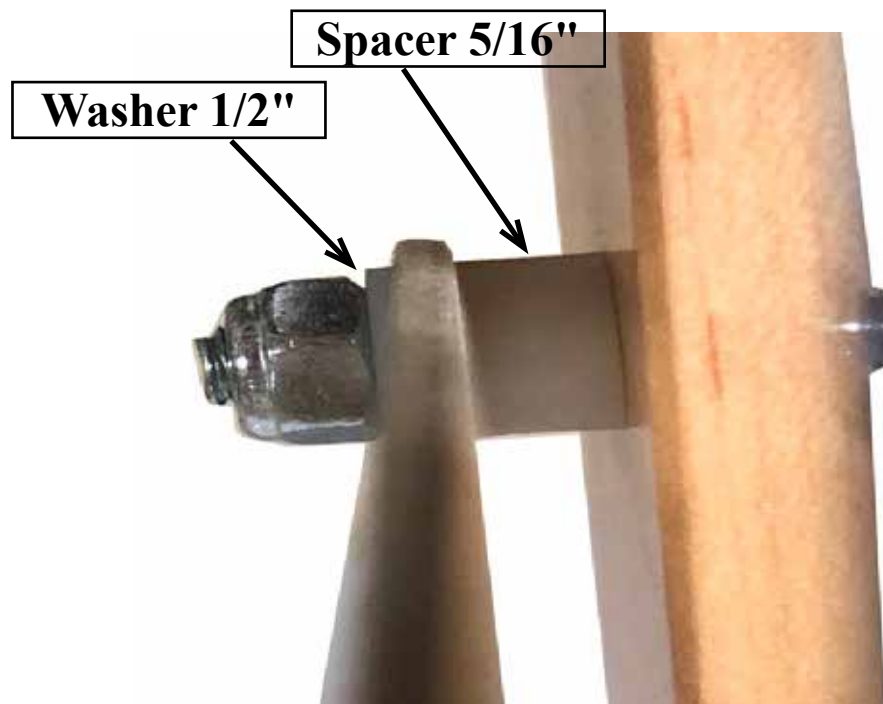
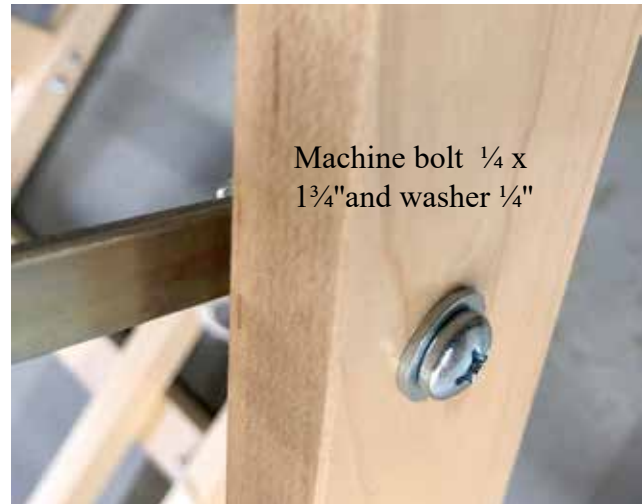

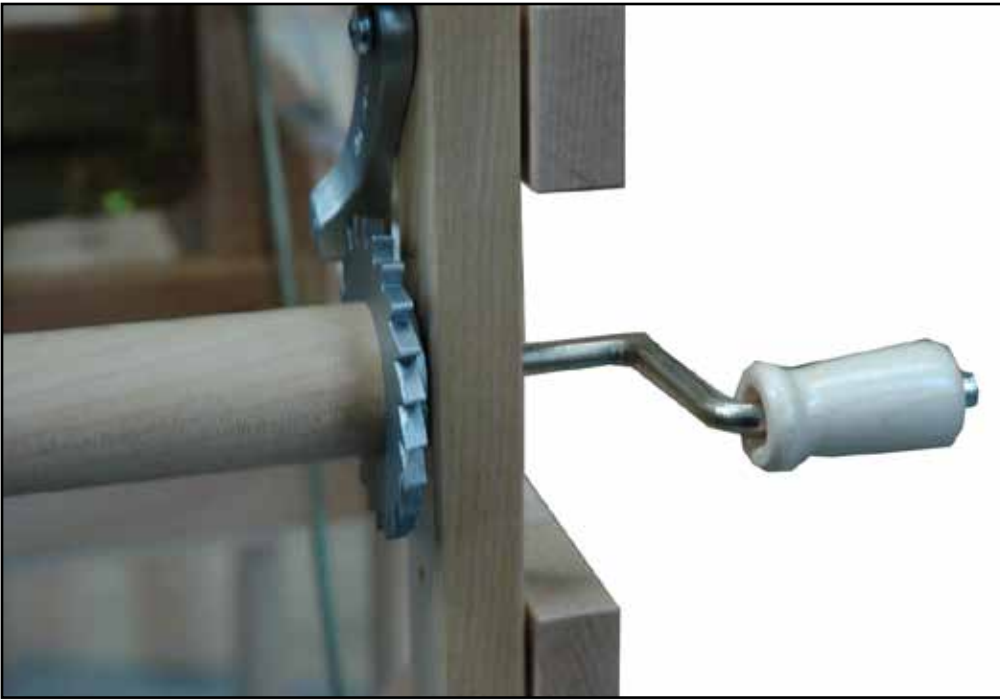

Install the Warp and Cloth Beam Cranks.

The loom is shipped with a bolt holding the warp and cloth beams. Unscrew the Bolts holding the beams and screw in the cranks. Screw in as far as possible while holding the beams with your hand.

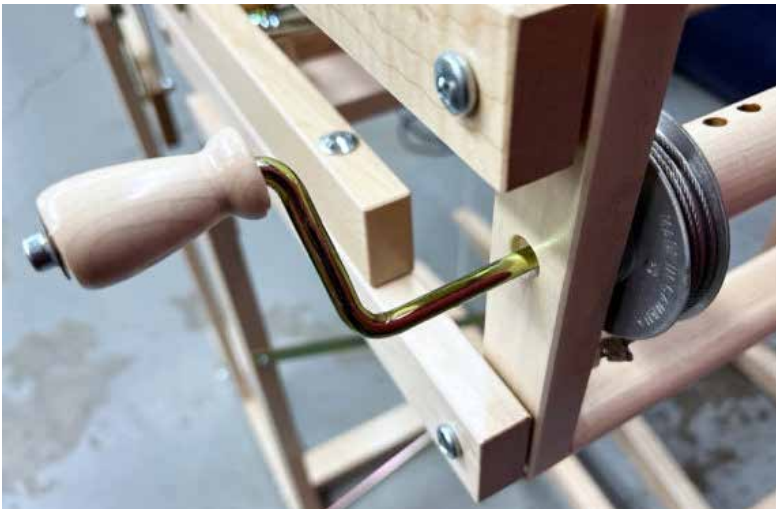

Friction Brake

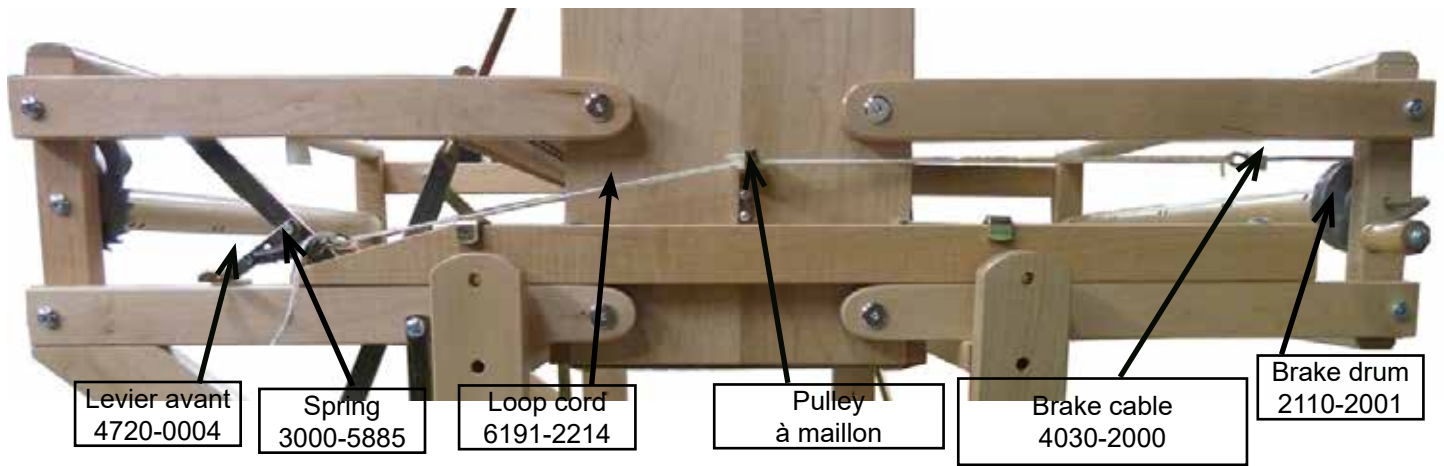

Turn 4 times the brake cables (WITH THE BRAKE LOOP CORD).

Place the first row inside the loom and the last row next to the back post.

The brake cable should now be in the groove of the brake drum and the 4 rows have to be side by side.

After the brake cable is wrapped around the drum, check to make sure you have not introduced a twist in the cable while installing it. This can cause the brake cable to overlap or come off the brake drum when the brake is released.

Pass the loop cord through the pulley and make the connection to the spring while the lever is up (release).

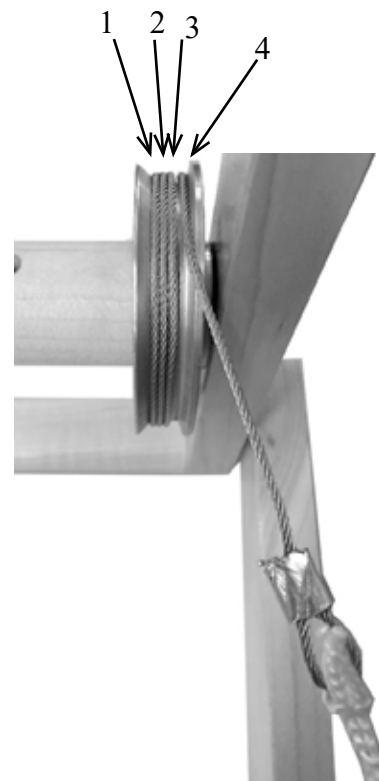
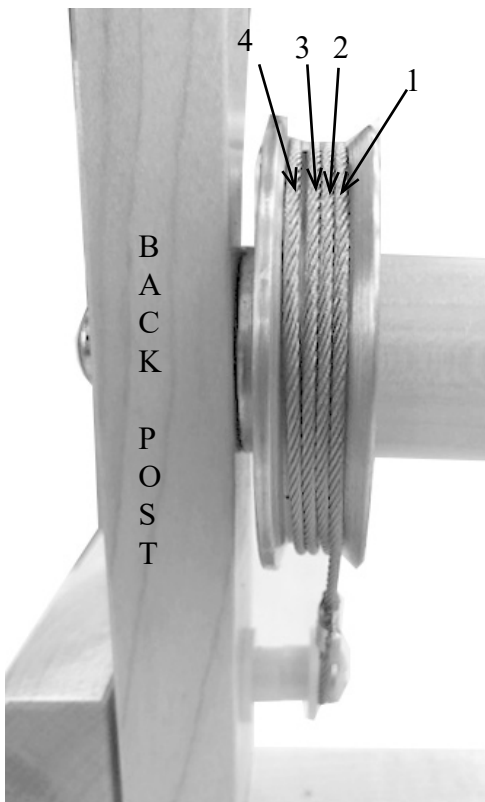

Brake off



Brake on

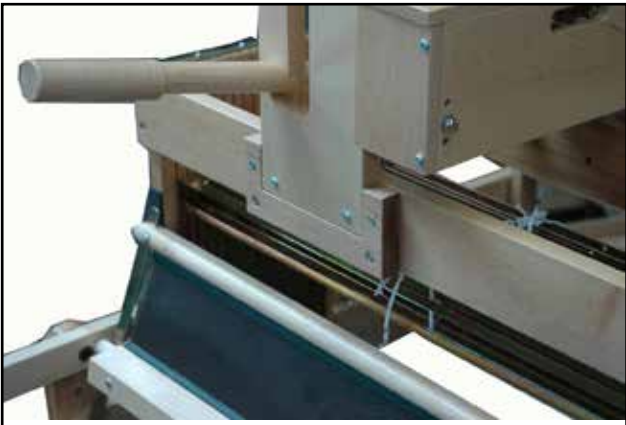

Put the shaft selector in place (sitting on the front and back guides) and affix it using 4 round head screws #8 - 1¼"
Make sure to screw into the pre-drilled holes.



Connect the loop cord between the knife and the screw on the outside of the handle by treading it under the support board around the two pulleys.
Slip the hole with the black mark around it over the screw.

The metal "L" shaped Pulley Guards should then be checked to make sure they are positioned correctly to keep the cord from coming off the pulley.
The guard should be positioned so it is centred on the part of the cord that is touching the pulley.
Loosening the pulley screw slightly will allow the guard to be rotated and then tightening the screw will lock it into this position.

The cord will probably have to be adjusted later.
If this cord is too tight, the action of the handle will be too hard.
If the cord is too loose, the knife will not go completely down causing weaving errors.



Remove with care the solenoid unit from the shaft selector.

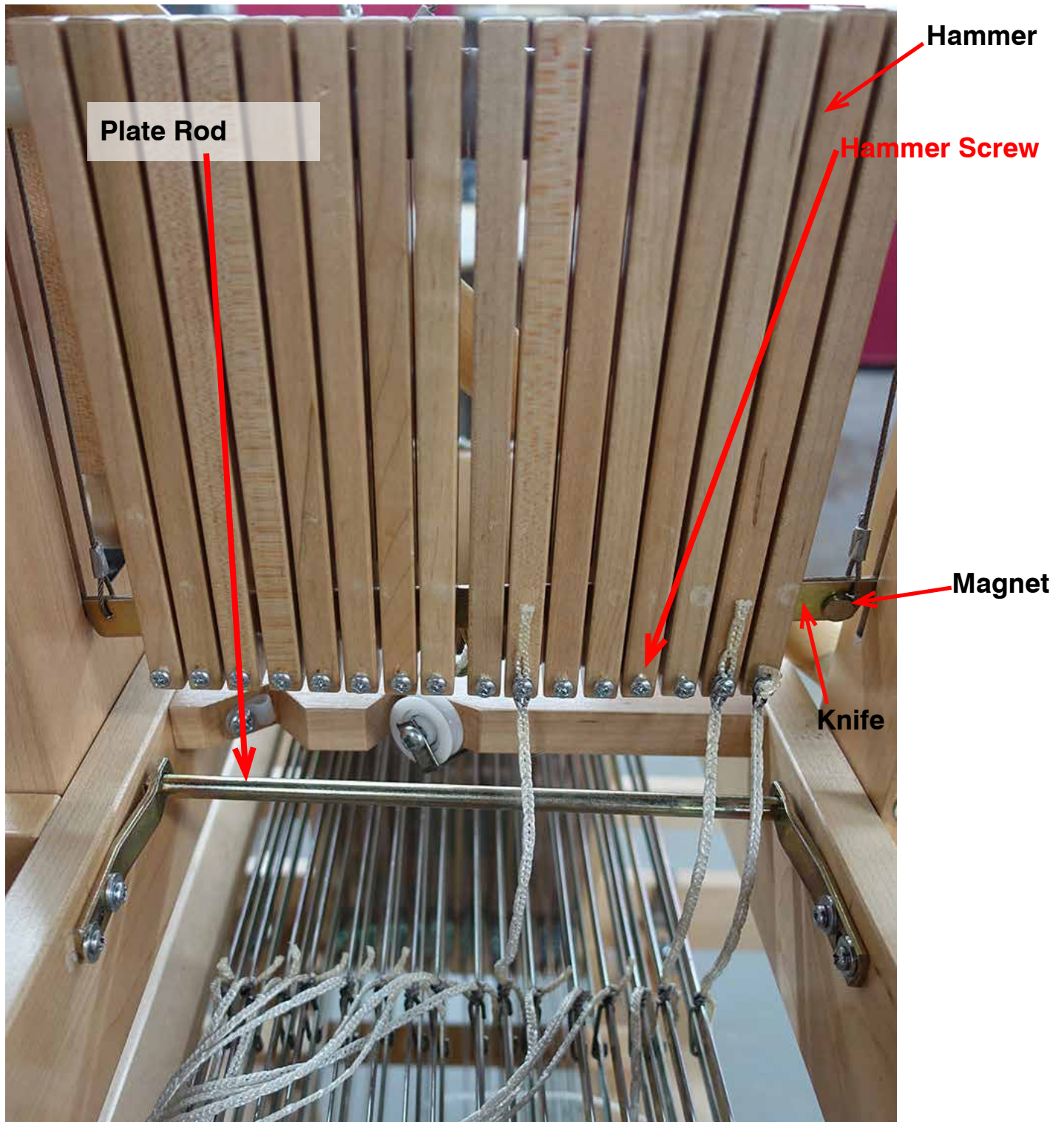

Connect shaft frame loop cords to each hammer at the black mark. Just pass hole of black mark around each screw of the hammer.
Make sure to pass loop cord **INSIDE** the gold plated rod as in the picture.

A small adjustment of the rod position can be made after removing the locking screw and loosening the rod adjustment screw. These control the position of the wooden hammer fingers relative to the knife and may require adjustment to ensure only the correct fingers are being caught by the knife. [Do not change this adjustment before calling Leclerc Looms at 819-362-7207](tel:819-362-7207)

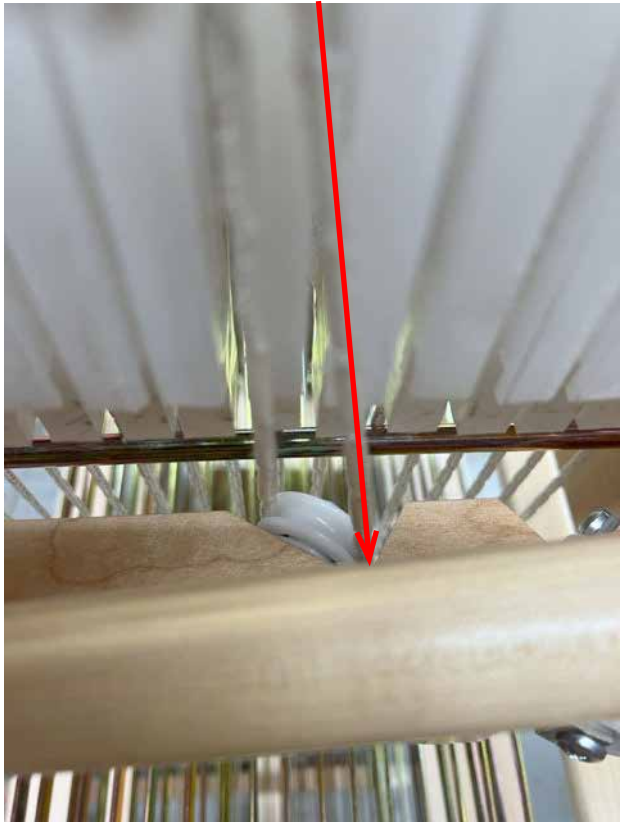

Install the loop cord joining the screw hook of the left treadle and the hook under the knife, threading it between the shaft frames #6 and #7. Adjust the length so the knife is at the low position when the left treadle is depressed.

Make sure that the loop cord in the knife hook does not catch the hammer when the knife is raised. Put the end of the cord in front of the knife.

Hook the top part of the loop cord (M) to the screw in the back of the handle (H).

Thread this loop cord through the nylon guide (G) and between the shaft frames #2 and #3 to the hook on the right treadle.

Adjust the length so the shed is wide open (handle in the bottom of the slot) when the right treadle is depressed.

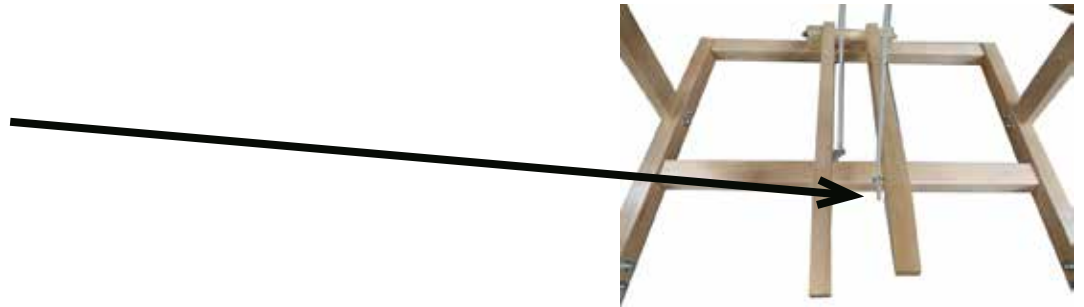

IMPORTANT NOTE:

The loom is designed to operate with two treadles. The right one lifts the shafts to open the shed. Never release the right treadle until all shafts are in the rest position, then complete the sequence by pushing the left treadle. It is very important to depress the left treadle in order to make sure all shafts are in neutral and to control the pattern advance.

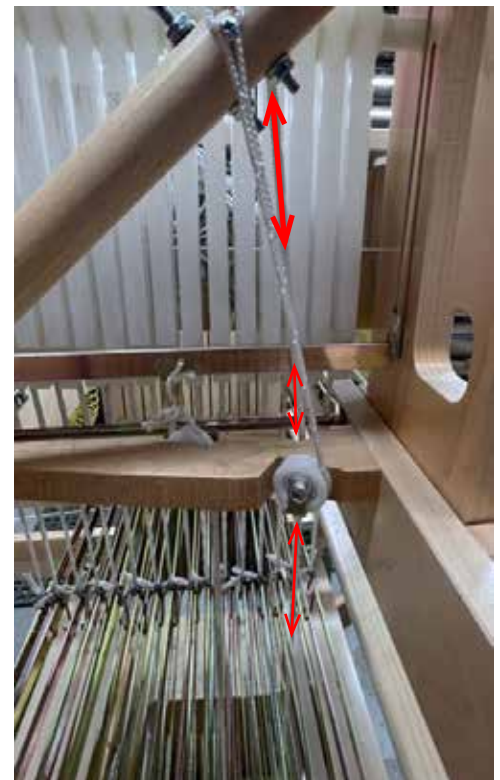
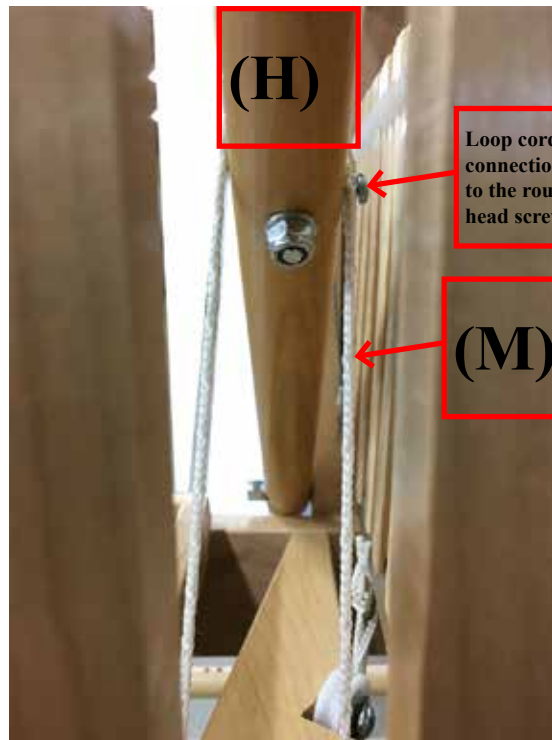



Put back with care the solenoid unit to the shaft selector making sure you screw to the predrill holes.
In order to see better the screws and the pre-drill holes, you can remove the cover "O"

HEDDLES

To insert the heddles in the shaft frames, remove the heddle bars (support) from each shaft frame by bending it a little. Do not overbend in order to keep them straight.

IMPORTANT:

In order to keep the loom balanced and in good operation, we recommend to put no more than 75 heddles per shaft frame.

If you need more, please use the Texsolv heddles for the extra quantity.

30) COMPUTER-DOBBY LOOM CONNECTION

Make sure that the black control box (interface box) and computer are both turned off and then connect the cables provided with the loom.

Before starting (ON) the box;

1) When plugging your computer directly to the interface box, you will use this cable:
Install the USB driver found on the USB key. (see next page 28)



2) You can also use the USB to serial using a non-supplied adapter"

3) For older computers with only a serial port, you can plug it directly into a serial port to serial port using the serial cable.

Never connect or disconnect the cables while the interface box is turned on.

Remove the cover (C) of the solenoid unit.

This solenoid box cover can remain off until you complete the installation and test the unit.

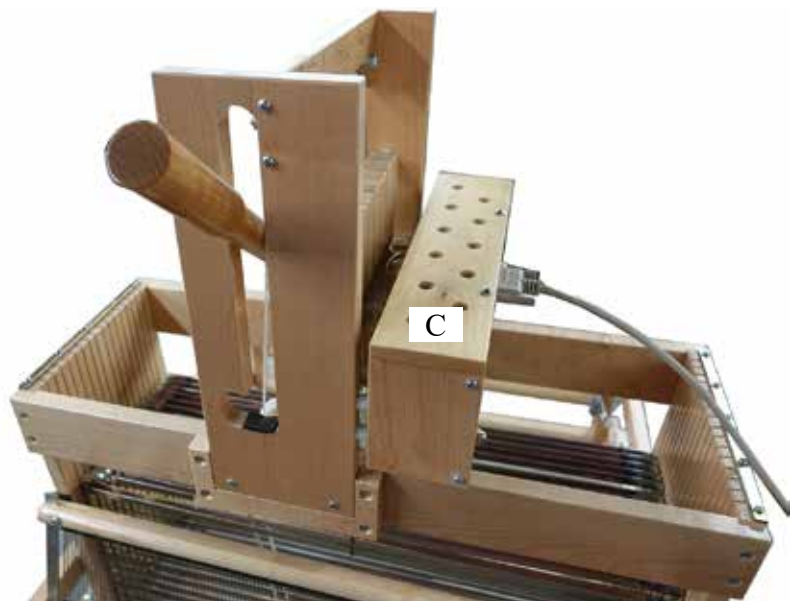

USB DRIVER INSTALLATION INSTRUCTIONS

recommend for newest computer only

1. Run one of those files from the USB Key: Videos/USB_Drivers/
 - 1) CP210x_Windows7-8-10_Drivers
 - 2) CP210x_VCP_XP-Vista
 - 3) Mac_OSX_VCP_Driver
2. Accept the Security Warning if any.
3. Click next on the Welcome screen
4. Accept the Licence Agreement
5. Accept the Destination Location
6. Install ok
7. Launch ok and finish
8. Restart your computer
9. Connect the USB cable to the computer.
10. Windows see the Silicone Labs com port
11. To see which com port it is, go to:
 - Control patern
 - Setup
 - Hardware
 - Device Manager
 - Ports, com port



Start your pattern software and select the right Com port

Start Weaving

For any problem, please contact:
info@leclerclooms.com

SELF TEST ACTIVATION WITHOUT THE COMPUTER

- 1) Make sure that the black box power switch is off (O)
- 2) Connect the cable(s) between the black box and the solenoid unit on the side of the loom.
- 3) Push th red (white) buttom and hold it in while turning the black box power switch on (I)
- 4) Release both buttoms at the same time.
- 5) The self test should start extending and then releasing the solenoids one by one.
Note that the sequesce is 1 to 32, so it is normal to have a delay before the sequence repeats on 16 and 24 shaft looms.
- 6) To stop this self test, switch the black box off (o).

STARTING THE UNIT WITH YOUR COMPUTER (Software with a Leclerc 24s or Leclerc II driver)

- 1) Make sure that the black box power is off (o)
- 2) If a conversion cable (USB to serial port) is being used, install the software driver supply with the adaptor (Not supply with the loom)
- 3) Connect the cables between the computer and the black box; and between the black box and the solenoid box on the side of the loom.
- 4) Determine which COM: PORT the serial port or the USB to serial port converter is using by checking the DEVICE MANAGER in Windows.
- 5) Make sure your LOOM DRIVER software is set with the same COM: PORT information
- 6) The loom is now ready to begin weaving.

STARTING THE UNIT

IMPORTANT:

This Interface box is a new version and will work only with the 24s or leclerc II software driver.

BEFORE YOU START THE SOFTWARE AND AFTER ALL CABLES ARE CONNECTED, TURN THE SWITCH OF THE BLACK BOX ON. LEAVE IT ON UNTIL YOU TURN THE SOFTWARE OFF. MAKE SURE THE KNIFE IS IN THE DOWN POSITION. (HANDLE IN TOP POSITION) TO CHANGE ANY CONNECTION, TURN THE SWITCH OFF.

The solenoid unit is adjusted and tested before shipping.

When the solenoids are in the push position (on) they must be at their maximum extension (or very close to it). If they are not at their full extension for some reason, they will overheat quickly.

It is important to check the action of each solenoid before you start, to determine that they are all functioning correctly. The easiest way to do this is with the self-test that is usually available with your design software.

Each plunger should move freely when not in action. If they are sticking, try to determine the cause or call for technical assistance.

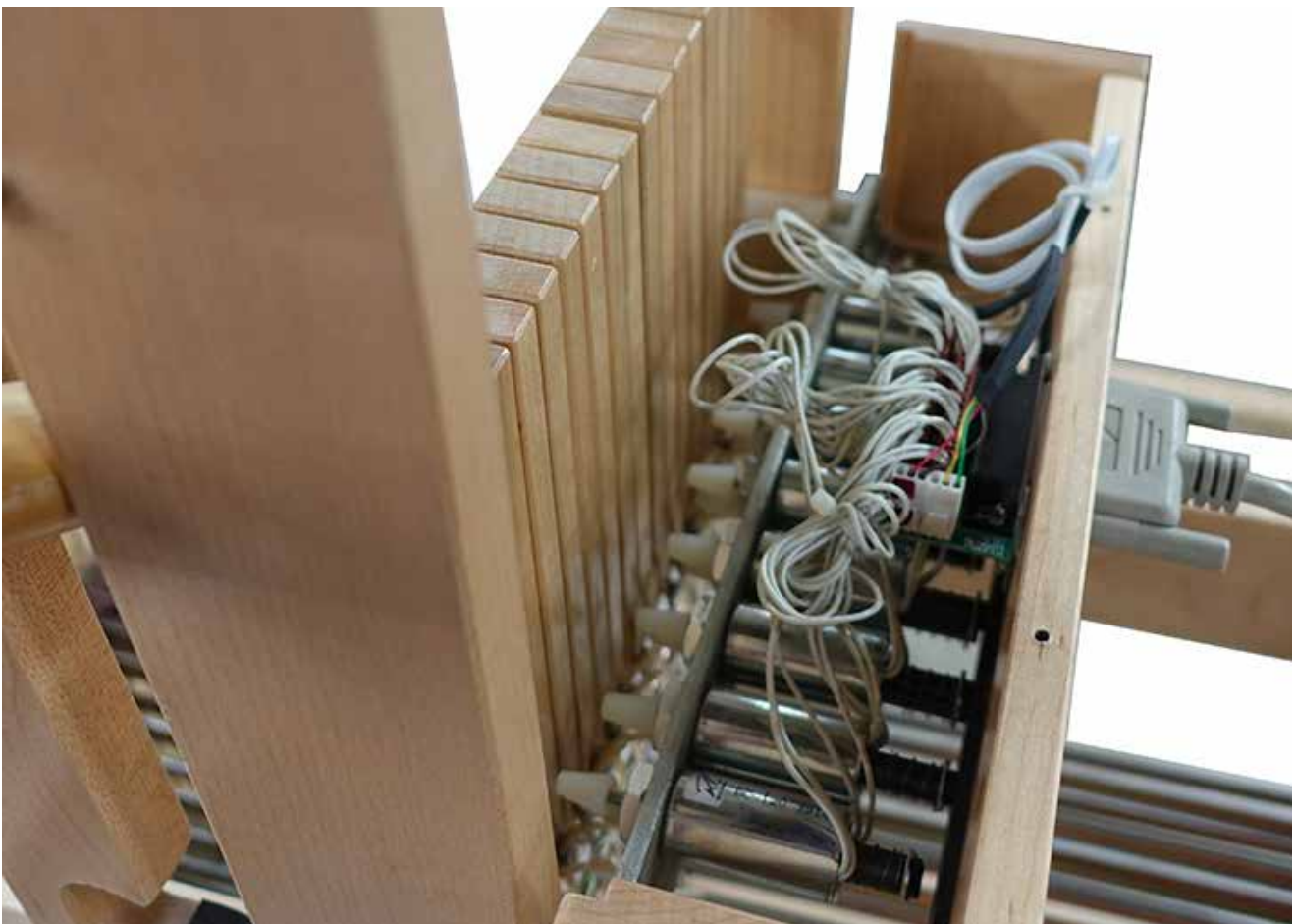

STARTING THE UNIT

IMPORTANT: The selecting arm (A) has to be in the top position when the selection of shafts are made (solenoids pushing)

BEFORE YOU START THE SOFTWARE AND AFTER ALL CABLES ARE CONNECTED, TURN THE SWITCH OF THE INTERFACE ON. LEAVE IT OPEN UNTILL YOU CLOSE THE SOFTWARE. TO CHANGE ANY CONNECTION, TURN THE SWITCH OFF.

NEVER START THE DOBBY SYSTEM WITHOUT THE SELECTING ARM ALL THE WAY TO THE TOP POSITION.

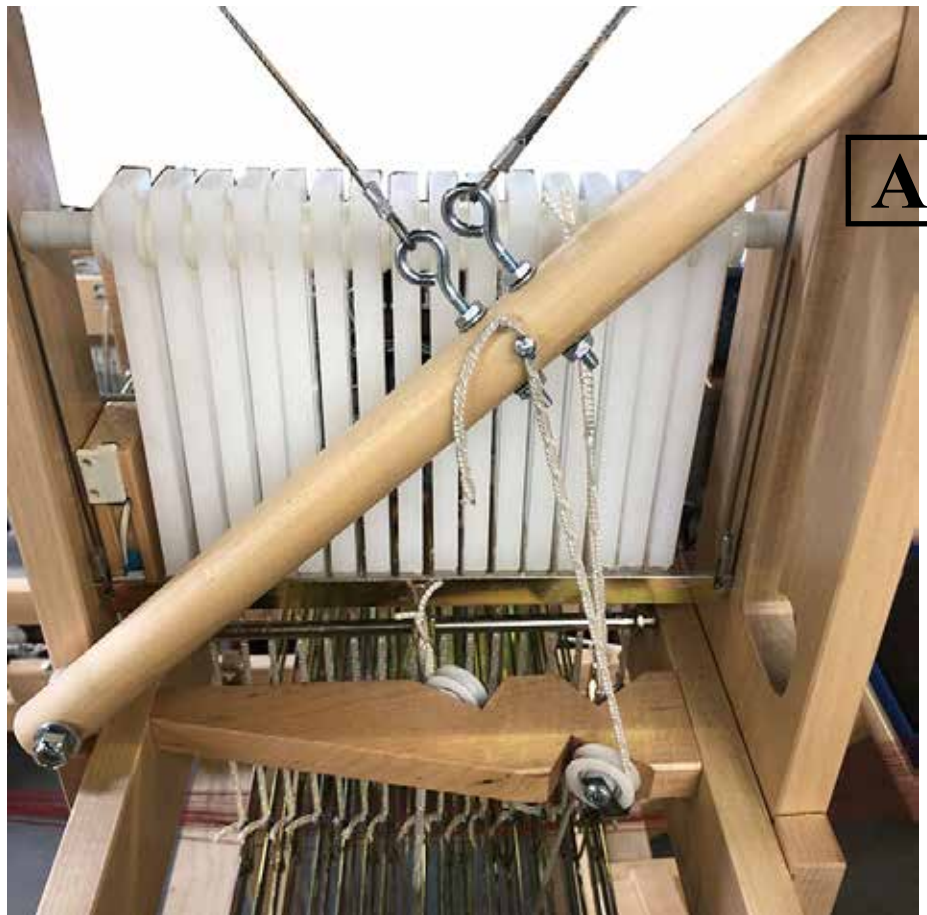

One pick sequence

a) Start Pattern (software). The solenoids activate, pushing the fingers forward.

b) As the knife moves up, the fingers are caught by the knife. The solenoids are release when the magnet install in the back of the knife pass in front of the upper sensors (U)

C) After the pick is woven and the shed closed, the next pick is made when the magnet pass in front of the lower sensor (L). The magnet have been glue to the back of the knife and should not be reposition unless instruction from Leclerc Looms.

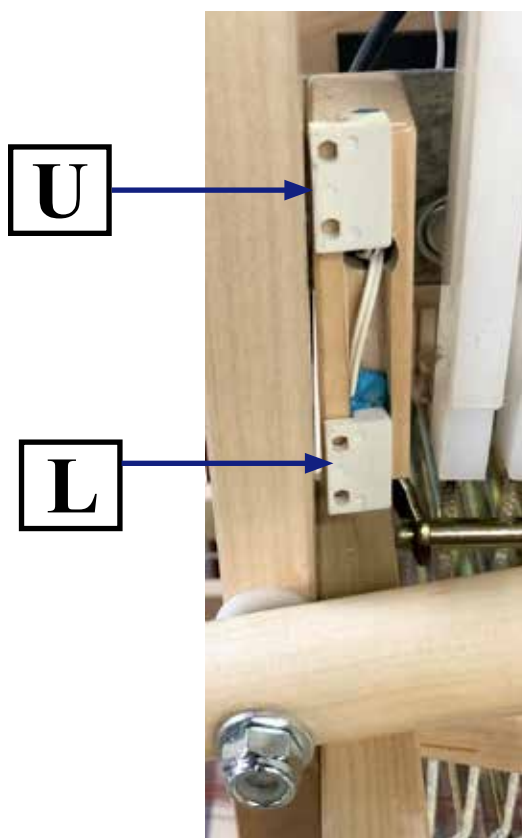

IMPORTANT NOTE:

If the solenoids does not move back in the step b, do not complete the opening of the shed, call your Leclerc dealer to to report this problm. The pick sequence have to work 100% of the time.

KNIFE ACTION

The knife, as illustrated in the photograph, catches any fingers that have been pushed forward by the solenoid. It is **VERY IMPORTANT** that the knife is in the lower position before you start weaving (first selection)

When you raise the knife with the front handle or the left treadle, the magnet, which is glued to the back of the knife, passes in front of two magnetic sensors. As it passes the top sensor, the solenoids will release.

As you complete this pick, by closing the shed completely (handle in the uppermost position or right treadle pushed down completely) the magnet will pass by the lower sensor and cause the pattern to advance one pick and then actuate the solenoids for the new pick.

The magnetic sensors are mounted in a slot behind the fingers. The sensors have been adjusted and glued in place before shipping. The position is marked on the block that the sensors are mounted on.

Both the sensors and the magnet work only on one side. If the magnet must be replaced do a test first and reverse if necessary.

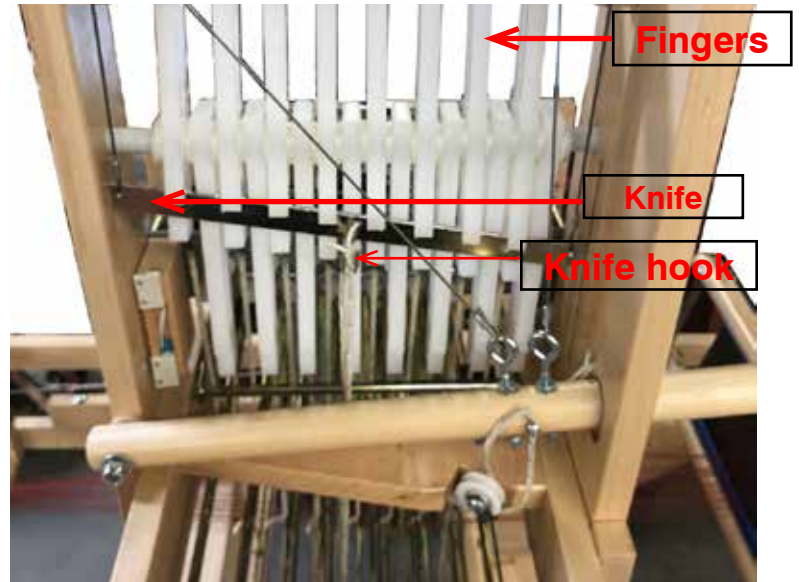

Down system function

There is a time out after 60 seconds of no activity. To continue weaving, you will have to stop and start your sequence in the loom control of your software.

MAINTENANCE

It is **very important** that all hammers are kept in clean condition. Application of furniture wax is a good idea to keep them moving easily.

Adjust the height of the beater so the yarn just touches the shuttle race.

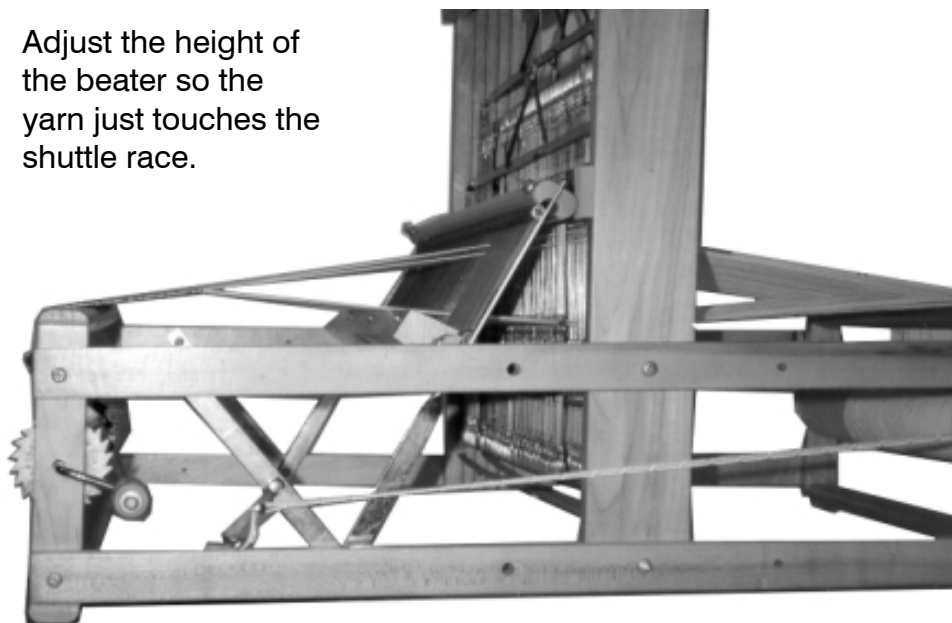

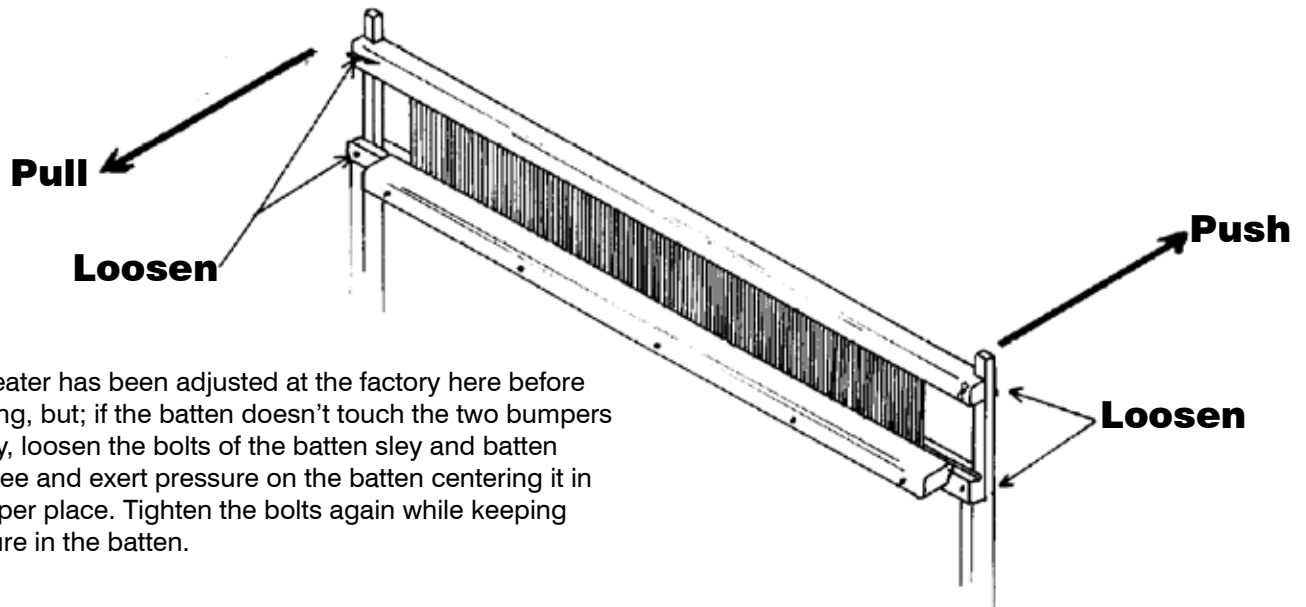

The beater has been adjusted at the factory here before shipping, but; if the batten doesn't touch the two bumpers equally, loosen the bolts of the batten sley and batten handtree and exert pressure on the batten centering it in its proper place. Tighten the bolts again while keeping pressure in the batten.



To ease weaving when sitted, you can remove the lower front cross-member.

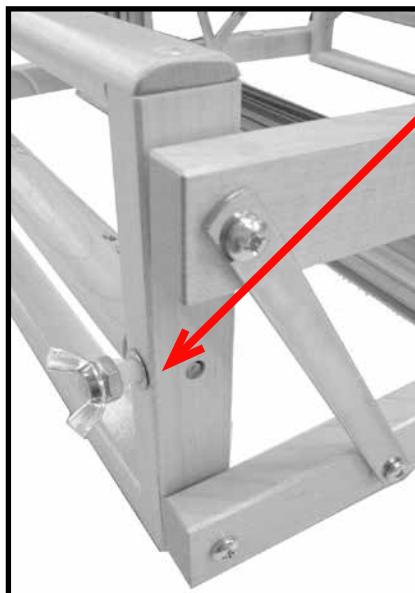

Warp beam advance control system

This system will eliminate excessive warp yarn advance when releasing the brake system at cloth take-up. This friction system is adjustable and have to be released when winding the warp on. Just screw the wing nut with nylon bolt to the left back post. Screw in to increase the friction or unscrew it to release.

Diana Loom
Instructions on how to keep your loom in good working condition

In order to keep your loom running smoothly, silicone lubrication is necessary.

We recommend using only 100% silicone products. No oil or grease.

Suggested Silicone spray:



We recommend spraying the following places, once a month if you weave 5 days a week or after weaving about 50 yards.



All the white washers between hammers



All the ball bearing pulleys

PREPARING (Stringing) WARP AND CLOTH BEAMS

- 1) Into 5 evenly chosen holes on each beam, thread one length of the loop cord.
- 2) Thread each loop cord back through itself, using the first hole in the Cord, as it comes out of the beam and pull tight.
- 3) Using the last hole of the free end on each Cord, pull a portion of the Cord through the hole forming a Loop. (A crochet hook can help you)
- 4) Slip a Bar through each loop of all cords and pull tight. (See diagram)



Important note:

Any modification to the loom or deviations from the assembly instructions may prevent the loom from working properly and void your factory warranty



**We at Leclerc encourage Weaver feedback on this and all our products. Please send your comments to
Leclerc Loom Co.**

HAPPY WEAVING

LECLERC LOOMS
P.O. BOX 4 1573 Savoie
PLESSISVILLE QC. CANADA
G6L 2Y6 819-362-7207
Fax: 819-362-2045
email: info@leclerclooms.com
www.leclerclooms.com

FRONT
AVANT
↓

INSIDE
INTÉRIEUR
→

FRONT
AVANT
↓

INSIDE
←
INTÉRIEUR

1 1

2 2

3 3

4 4



Écrire 1 2 3 4 au crayon feutre dans les rainures de la base et sur la partie int. des montants.

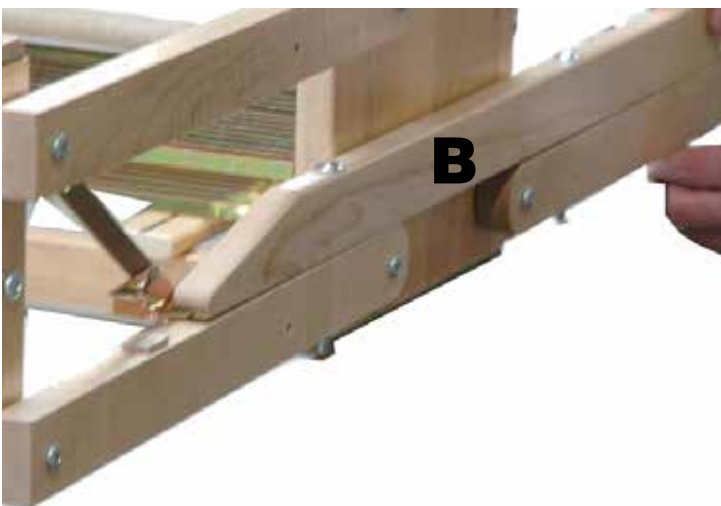

Écrire B sur l'intérieur du renfort droit et B1 sur l'intérieur du renfort gauche