

DOROTHY 24"

Please note that the loom is now 23½" weaving width. Please specify 23½" when you will order more reeds.

2410-0000 4 SHAFT LOOM
2411-0000 8 SHAFT LOOM
2412-0000 12 SHAFT LOOM

PARTS AS SHIPPED:

1 pre-assembled loom
1(2) (3) head 4 shafts (4 shaft I
4 (8) (12) screws #12 1¼" (for
1 Multi bits screwdriver
2 cranks
1 reed 12 dents per inch
600 wire heddles 9½"
1 boat shuttle 6122-0000 (SLIM
1 reed and heddle hook 6141-
2 lease sticks
10, 18" (46cm) loop cords for la
2 (steel) warp rods
1 book Warp and Weave



Leclerc Looms

Since 1876



1972 Avenue Simoneau
C. P. 4
Plessisville, Qc.
G6L 2Y6

TEL: 819-362-2408
FAX: 819-362-2045

LECLERC NOTE IN FRENCH:

Pour un métier 8 lames mettre le cliquet de tête plus haut et identifier que la tête #1 va au milieu et la tête #2 à l'arrière. Pour le 12 lames mettre la tête avec cliquet plus haut à l'arrière. Dans les 2 cas, monter et vérifier les têtes sur le métier.

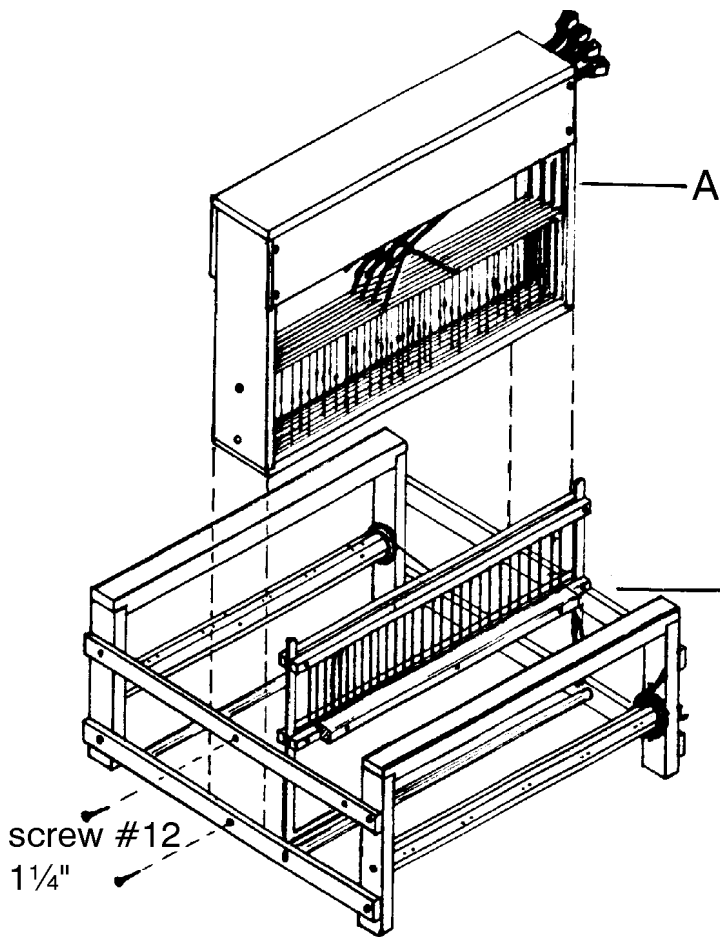

After unpacking the loom, unfold the base and put the two little metal hooks (at the front side) in position (over the screws) and screw them in slightly so they hold in place.

Take off the machine screws which are at the end of the beams and attach the crank to the right hand side by turning it. Because the metal of the crank is plated, it may be little difficult to attach the crank but take your time, it is the right size. Push and turn on the right hand side slowly.

To set up the loom, put the head section A containing 4 shafts in the bottom frame B and attach each side with the 4 screws.

The reed can be removed easily by loosening the screws and raising the top piece.

To install the heddles, remove the heddle support by curving it slightly. Distribute them evenly within the shaft frame. There are enough heddles to weave full width with 24 threads per inch.

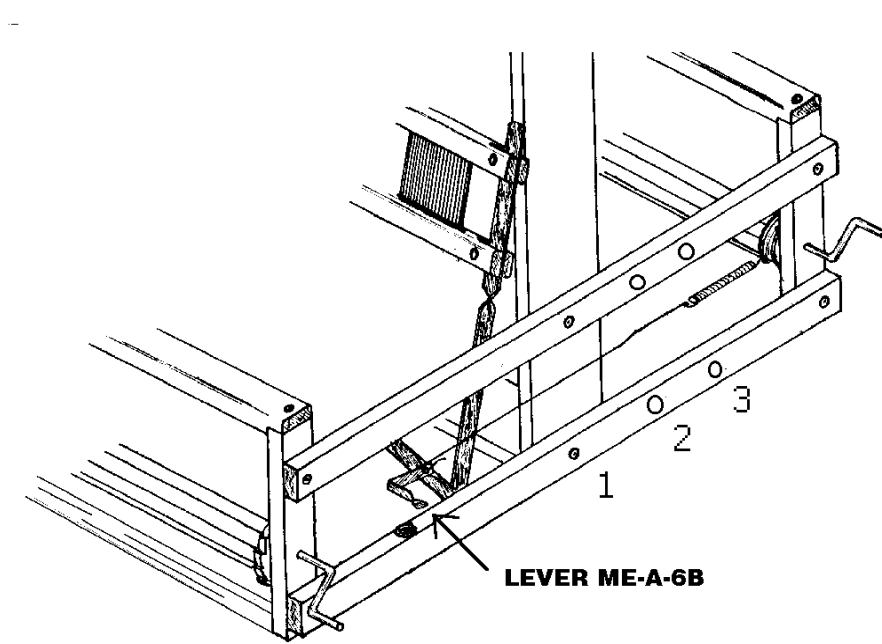

If the loom has only 4 shafts, the head section goes in the middle (2) of the frame.

If the loom has 8 shafts, put shaft section #1 in the middle (2) and shaft section #2 in the back (3) position. If your loom is a 12 shaft one, shaft section #1 goes in the front, #2 in the middle and #3 goes in the back (3).

Head section #2 and #3 have lever catch set higher so the shed is clear.

Friction Brake

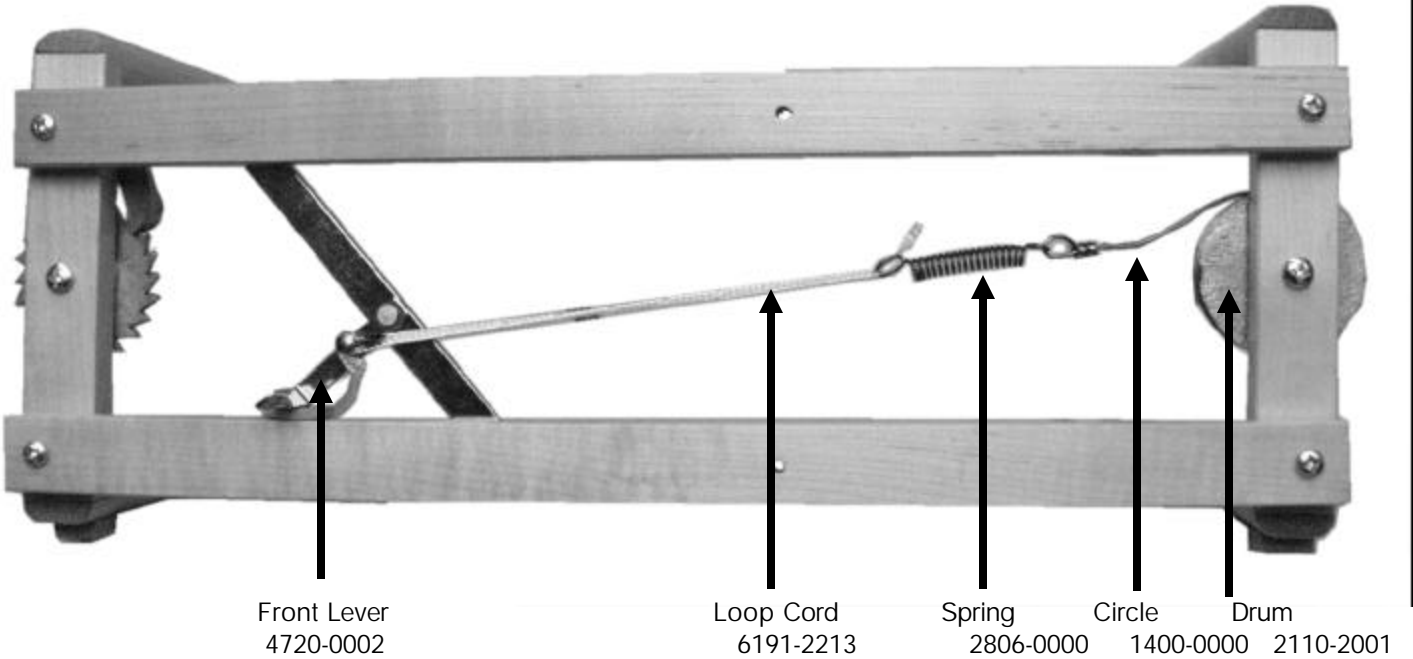

The length of the loop cord has been marked (black mark to the front lever) and tested before shipping.

To advance the cloth, pivot the front lever to the back of the loom in order to release the tension on the circle. When sufficiently advanced, pivot the lever back to the front to re-establish the tension on the brake circle. Tighten the warp with the warp beam crank.

If the warp beam turns forward while weaving, shorten the loop cord to increase the tension on the brake circle. Disconnect the loop cord from the lever to warp the beam.



Adjust the height of the reed so the bottom warp threads just touch (or are just a little lower than) the shuttle race when the shed is open. Shed should be at least 1½". If the shed is smaller, you probably weave too close to the reed and (or) the tension on the warp is too high.

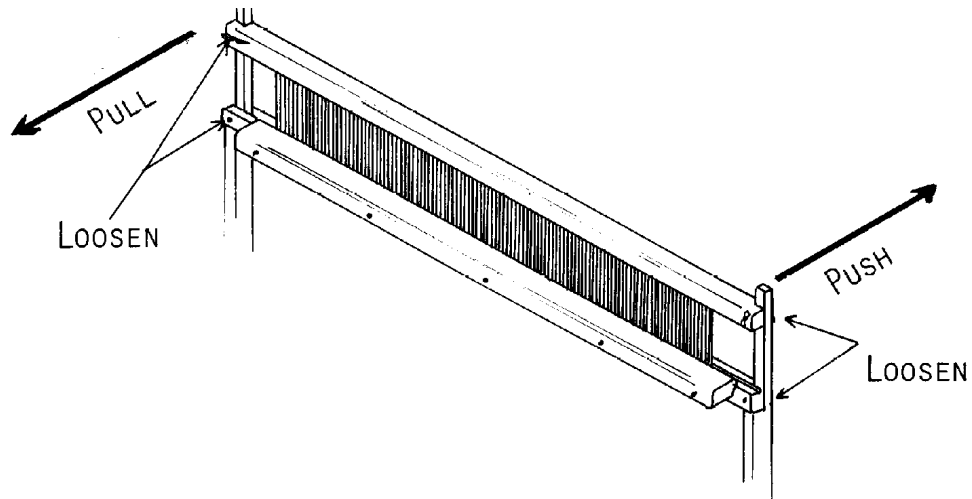

The beater has been adjusted at the factory before shipping. If the batten doesn't touch the two bumpers equally, loosen the bolts of the batten sley and batten handtree and exert pressure on the batten centering it in its proper place. Tighten the bolts again while keeping pressure on the batten.

PREPARING (Stringing) WARP AND CLOTH BEAMS

- 1) Into 5 evenly chosen holes on each beam, thread one length of the loop cord.
- 2) Thread each loop cord back through itself, using the first hole in the Cord, as it comes out of the beam and pull tight.
- 3) Using the last hole of the free end on each Cord, pull a portion of the Cord through the hole forming a Loop. (A crochet hook can help you)
- 4) Slip a Bar thru each loop of all cords and pull tight. (See diagram)

All Cords should be exactly the same length in order to make an even tension.



Always maintain a good tension on the warp when weaving.

PROMPTLY CALL YOUR DEALER OR LECLERC FOR ANY

LECLERC LOOMS
P.O. BOX 4
1972 SIMONEAU
PLESSISVILLE QC. CANADA
G6L 2Y6
819-362-7207
Fax: 819-362-2045
courriel: leclerc@leclerclooms.com
www.leclerclooms.com