

**STAND BASE FOR  
DOROTHY 24"  
8s Loom  
6313-2008**



1972 Avenue Simoneau  
C. P. 4  
Plessisville, Qc.  
G6L 2Y6

**PARTS AS SHIPPED:**

- 1 stand base with treadles assemble
- 1 set of lam with upright assemble
- 8 carriage bolts 5/16" x 2"
- 8 washers 5/16"
- 8 wing nuts 5/16"
- 4 carriage nuts 1/4" x 1 3/4"
- 4 washers 1/4"
- 4 square nuts 1/4"
- 24 treadle cords 14" long
- 8 loop cords 28" long with S hook
- 10 treadle hooks 7"

TEL: 819-362-2408  
FAX: 819-362-2045



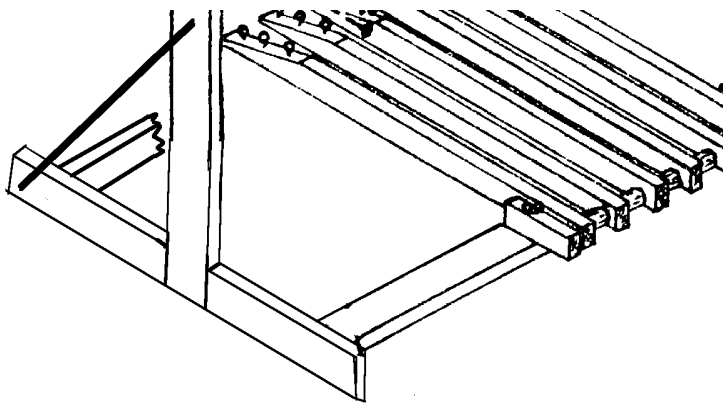

Screw the Upright post to the base using the 4 Carriage bolt  $\frac{1}{4}$ " x  $1\frac{3}{4}$ ", 4 washers  $\frac{1}{4}$ " and 4 square nuts  $\frac{1}{4}$ "

Unscrew the bolt holding the lams and put them in the upright post bracket using the same bolt.

With a  $\frac{1}{4}$ " drill, bore a hole in each cross piece of the loom entering the drill in the hole of the stand post. Make sure the loom is well balance.

Screw the loom in place using the :

- 4 carriage bolts  $\frac{5}{16}$ "
- 4 washers  $\frac{5}{16}$ "
- 4 wing nuts  $\frac{5}{16}$ "

Height of the loom can be adjust using different combination of holes in the upright post.

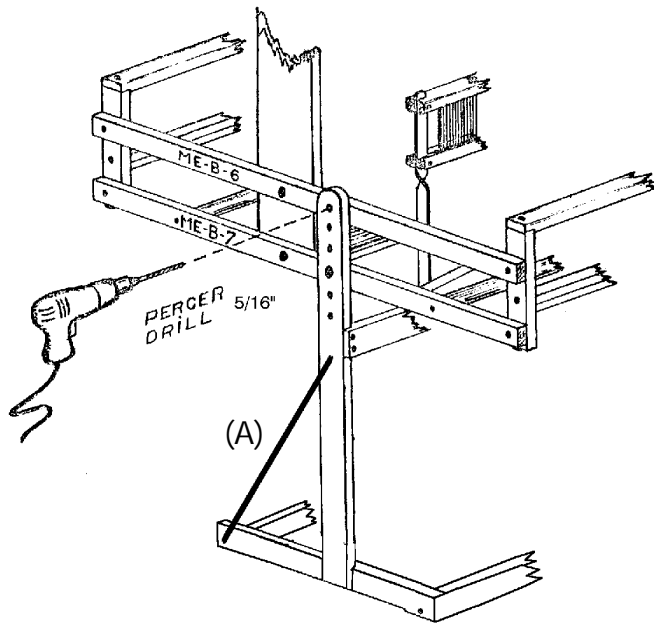

Using the square head screwdriver supplied with loom or a std. philips screwdriver, install the metal post (A) using the 2 screws #12  $\frac{3}{4}$ " already in the uprights.

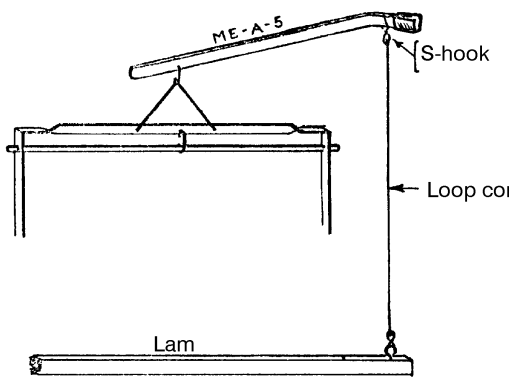

Install the loop cord. Place the S-hook over each lever and insert the other end of the cord in lam's hook. Adjust the lenght by using different hole in loop cord.

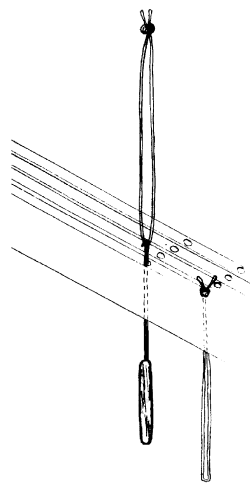

To lock the dog for levers when you treadle, place a piece of cardbord between the dog and the right hand screw.

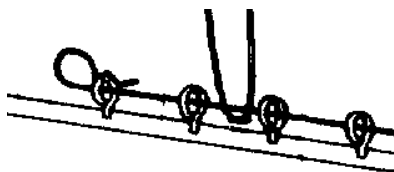

Install the treadle cords trough the lam and treadle hooks. For more information, see book Warp & Weave supplied with the loom.