

**Métiers Leclerc
Leclerc Looms**



1573 Savoie
C. P. 4 Plessisville, Qc.
G6L 2Y6
TEL: 819-362-7207
FAX: 819-362-2045
www.leclerclooms.com
info@leclerclooms.com



**STAND FOR
DOROTHY OR VOYAGEUR
24"**

4/8/12 OR 16S
(Can be adjusted to
4 different heights)

***BASE DE DOROTHY OU
VOYAGEUR 24"***
4/8/12 OU 16 CADRES
(Ajustable 4 hauteurs
différentes)

**6313-2008
6313-2024**

PARTS LIST

LISTE DE PIÈCES

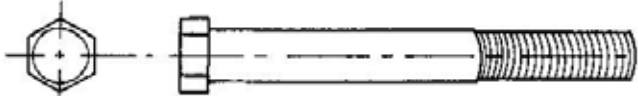

4 Machine bolts 5/16" x 1 1/2"
4 boulons machine 5/16 x 1 1/2"



4x Wing nuts 5/16"
4x Écrou papillons 5/16"

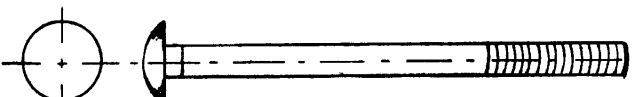

1/4" x 1 3/4"
8x Carriage Bolts
8x Boulons voitures



8x Washers 1/4"
8x Rondelles 1/4"



1/4"
8x Autolock nuts
8x Écrous auto-bloquant

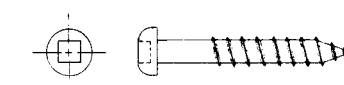

Round head screws
Vis tête ronde
8x #14 2 1/2"
16 #6 5/8"

2 Screwdrivers
Black / Vert
2 Tournevis



1 Wrench
1 Clé ajustable



1 long crank for back beam (6")
1 manivelle longue (extra) pour
ensouple arrière (6")



2x Shelves (S)
2x Tablettes (S)

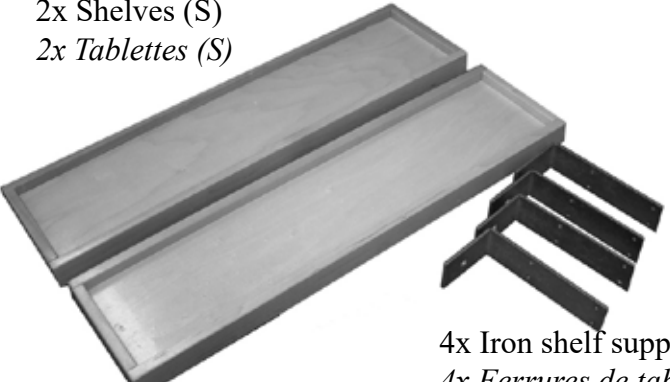

4x Iron shelf support
4x Ferrures de tablettes

4 Uprights (M)
4 Montants (M)

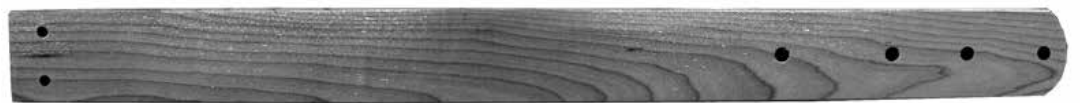

1 right and 1 left base (B)



1 base droite et 1 base gauche (B)



2 Lower cross-members (T)
2 Traverses du bas (T)



2 Upper Cross-members (T2)
2 Traverses du haut (T2)



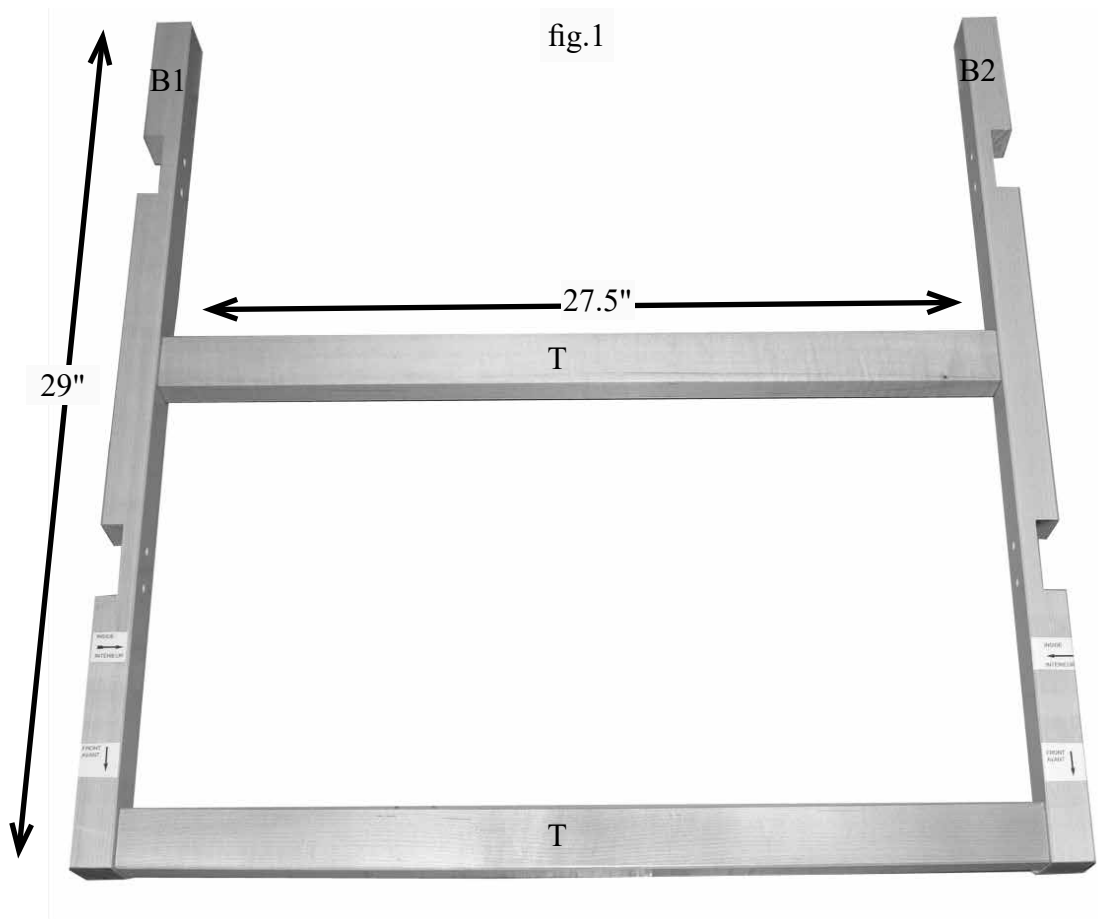

Screw the side base parts to the base cross-members using the 8 round head screws #14, 2½"

Assembler les côtés de la base aux traverses utilisant les 8 vis tête ronde #14, 2½"

Affix the upright using the carriage bolts $\frac{1}{4}$ ", the washers $\frac{1}{4}$ " and the autolock nuts $\frac{1}{4}$ ".

Affix the upper cross-member (T2) using the 4 machine bolts and the wing nuts. Install this cross-member at the desired height. At the same time, install the shelves on each side (see next page).

Assembler les montants (M) utilisant les boulons voitures $\frac{1}{4}$ ", les écrous "auto-bloquant $\frac{1}{4}$ " et les rondelles $\frac{1}{4}$ ".

Utiliser 4 boulons machine 5/16 et 4 écroux papillons 5/16" pour:

Poser les traverses (T2) à la hauteur désirée. Poser en même temps les ferrures de tablettes (voir page suivante pour photo).



fig.2

Affix the shelves on their supports with the #6 round head screw.

Utiliser les vis #6, 5/8" pour visser les 2 tablettes sur les ferrures de tablettes.



fig.3

According to your loom model and the adjustment of the height of the stand, you may have to change the back crank of the loom with the crank supplied with the stand.

Selon le modèle de votre métier et la hauteur à laquelle la base a été ajustée, vous aurez peut-être à changer la manivelle arrière du métier par celle fournie avec la base.

Install the loom on its stand and secure it in place with the four stand handles.

Installer le métier sur la base et le fixer en place avec les 4 poignées de la base.

Front right view

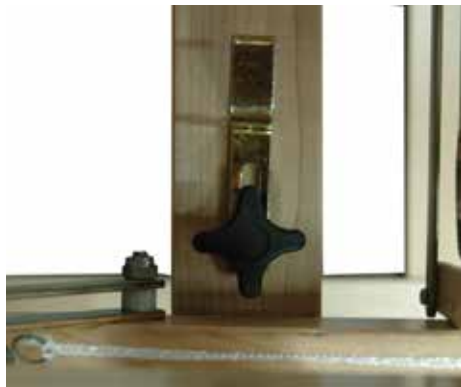

Vue avant droit

fig.4

Front right view



Vue avant droit

fig.5

Back left view



Vue arrière gauche

fig.6

To ease weaving when the loom is on its stand, you can remove the lower front cross-member.

Pour faciliter le tissage lorsque le métier est sur la base, vous pouvez retirer la traverse inférieure avant du métier.



fig.7