

# Leclerc Looms

Since 1876



1573 Savoie  
C. P. 4 Plessisville, Qc.  
G6L 2Y6  
TEL: 819-362-7207  
FAX: 819-362-2045  
www.leclerclooms.com  
info@leclerclooms.com

## NILUS 4 s

27"	1025-0027
36"	1025-0036
45"	1025-0045
60"	1025-0060



On receiving the loom, unpack and lay out the loom components.  
Do NOT discard any packing material until all parts are inventoried.

Check the parts received against the parts list on pages #2 to #7 of the assembly instructions. Report any discrepancies to Leclerc immediately.

To assemble this loom, a minimum of 2 people are needed but it is recommended you use 3.

Loom Prepared by: \_\_\_\_\_

Inspected by: \_\_\_\_\_

Date: \_\_\_\_\_

# PARTS LIST

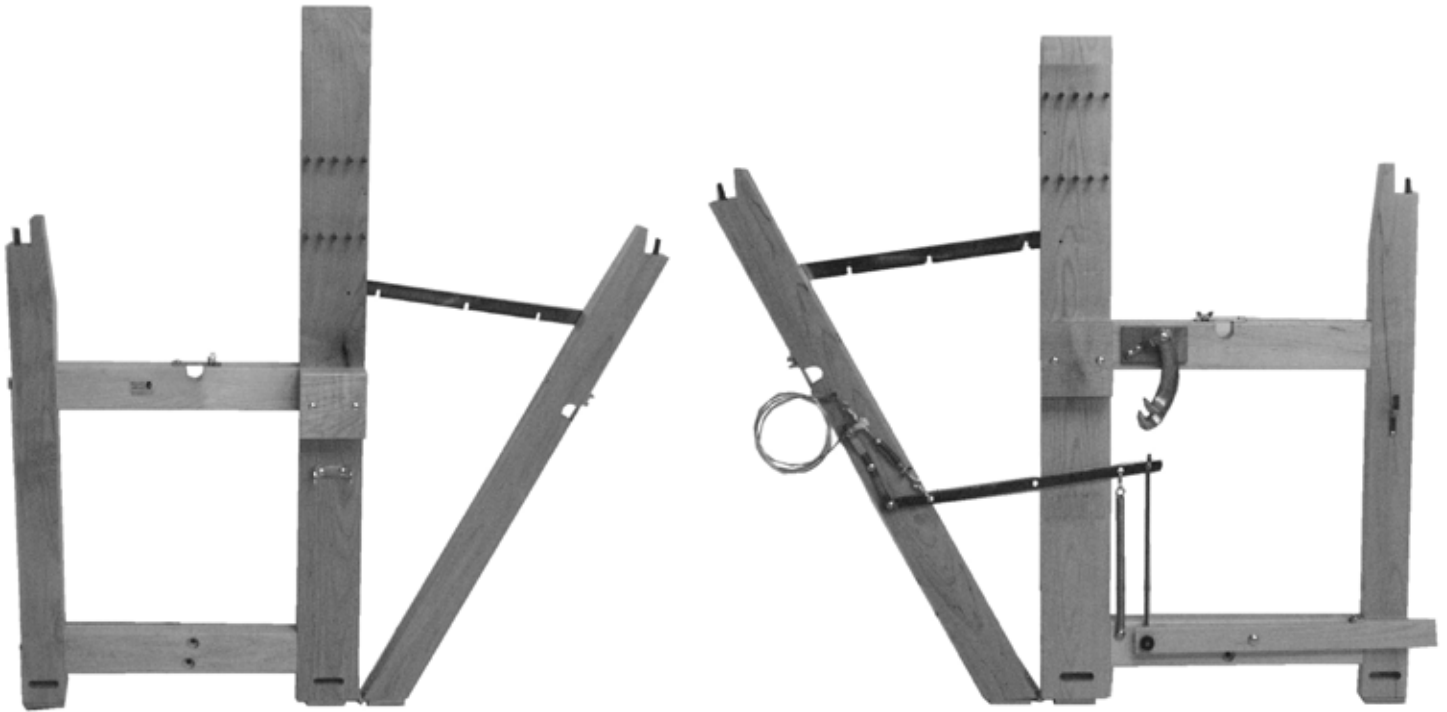

1 left-hand side

1 right-hand side



New:  
Stabilizing post  
pre-installed

Note for Leclerc in French :

Faire les petit trous dans les montants pour les baguettes d'encroix.

Mettre les blocs de boite à marmousset et le support de contremarche.

Re-faire le trou supérieur avant du bloc droit de la boite à marmousset avec un angle pour pouvoir visser la planche.

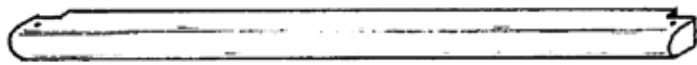

2 breast beams  
(34 5/8", 43 1/2", 52 5/8", 68 1/8")



1 left sword (33 1/8")

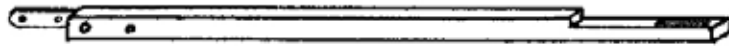

1 right sword (33 1/8")

Vérifier que les bagues entre bien dans les pattes et traverses

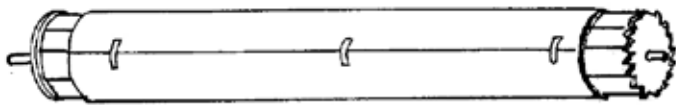

1 cloth (front) beam  
(29 1/2", 38 1/2", 47 5/8", 62 9/16")

Avec Bagues (Bushings)

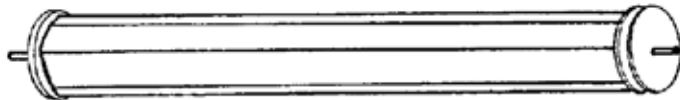

1 warp (back) beam  
(29 11/16", 38 1/2", 47 5/8", 62 9/16")



1 batten handtree  
(37 3/4", 46 3/4", 55 3/4", 70 3/4")



1 batten sley with shuttle race  
(37 3/4", 46 3/4", 55 3/4", 70 3/4")

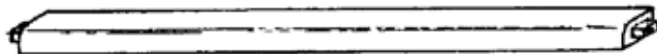

1 Middle set cross-member  
(31 1/8", 40 1/8", 49", 64")

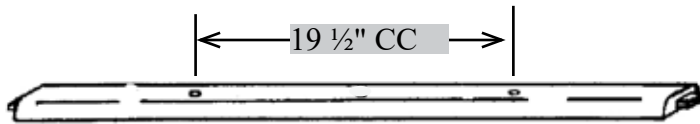

1 lower middle cross-member  
(31 1/8", 40 1/8", 49", 64")

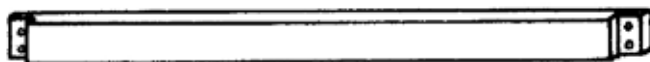

1 Front cross-member  
(34 1/4", 40 1/8", 49", 64")

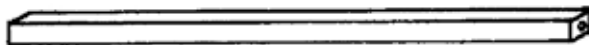

1 stabilizing post cross-member



1 apron



1 cloth take-up motion handle

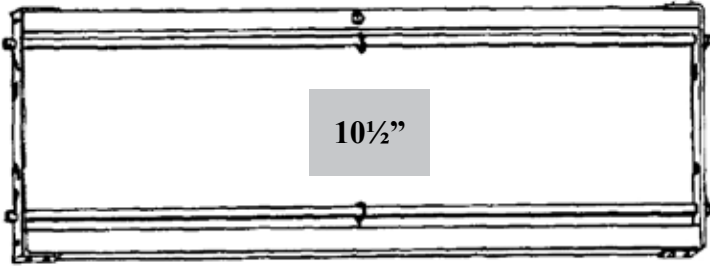

4 shafts



6 treadles with extension

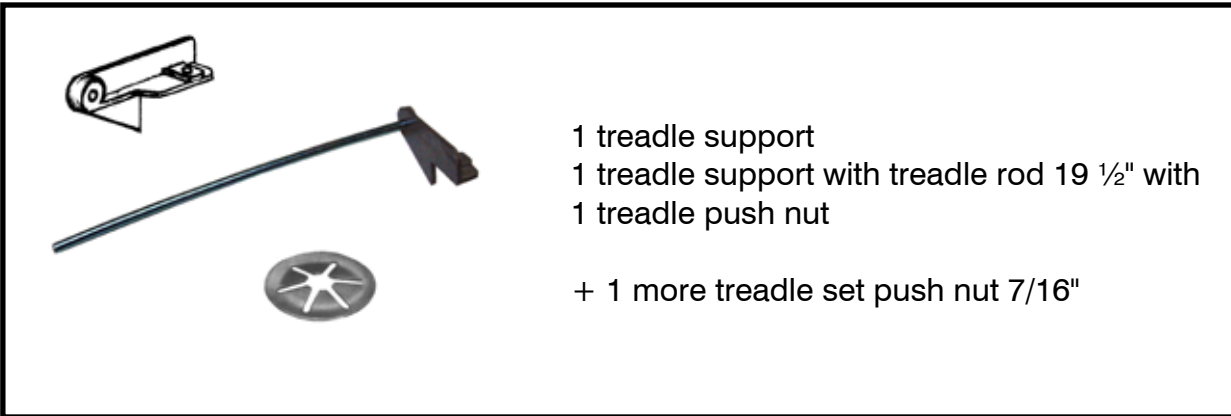

1 Crank

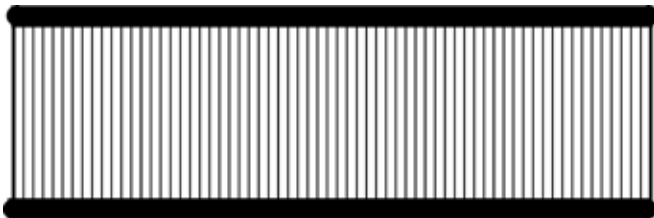

1 reed



2 lease sticks



4 warp rods



3 screwdrivers (Black, Red and Green)



1 adjustable wrench

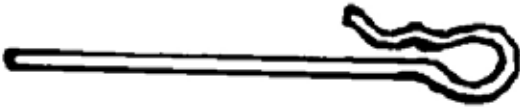

1 set of 6 treadle hooks 7" # 3000-4521



1 sets of 12 treadle cords 7" #3000-7011



1 boat shuttle (Reg.)



12 plastic bobbins 4"



1 threading hook



2 pkg of cords (5 yds each)



1000 heddles (36" loom)  
1200 heddles (45" loom)  
1500 heddles (60" loom)

10½"



4 lams

CC  
 27" = 14 9/16"  
 36" = 19 1/16"  
 45" = 23 9/16"  
 60" = 31 1/16"

OA  
 27" = 23 3/4"  
 36" = 28 1/4"  
 45" = 32 3/4"  
 60" = 40 1/4"

Note pour Leclerc:  
 Toujours vérifier si le crochet à ros passe bien dans les trous des contremarches.

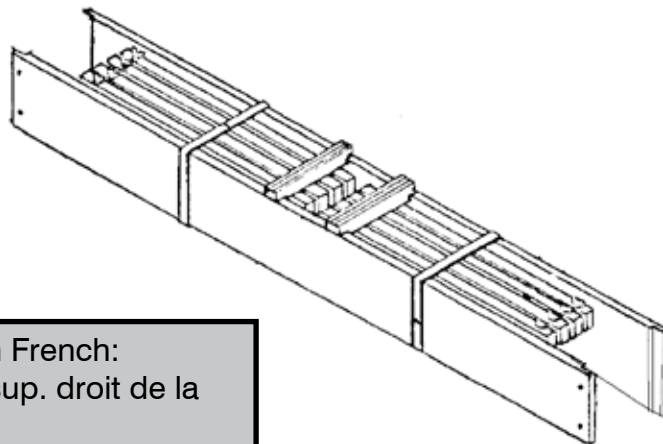

1 BOX JACKS (4)

**Do not remove saran wrap before the unit is installed on the loom.**

Note for Leclerc in French:  
 1) Refaire le trou sup. droit de la planche à angle.  
 2) Faire la tablette du 36" à partir d'une tablette 45" - 41 5/8" cc

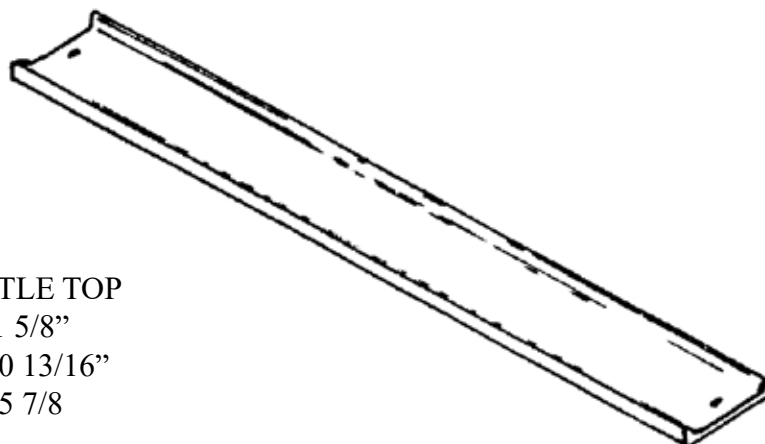

1 CASTLE TOP  
 36"=41 5/8"  
 45"= 50 13/16"  
 60"= 65 7/8"



1 warp beam advance control 3"

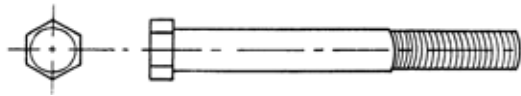

Machine bolts  
 4 X - 3/8" x 5"  
 1 X - 1/4" x 4"



Carriage Bolts  
 2 X - 1/4" x 2 1/2"  
 6 X - 5/16" x 2 1/2"  
 2 X - 5/16" x 2 1/4"



4 X - 3/8"  
 9 X - 5/16"  
 2 X - 9/16" (treadle set)  
 2 X - 1/4"



Hexagonal nuts  
 1 X - 1/4"

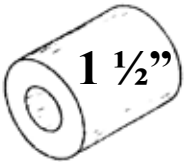

Wooden spacer  
 5 X 1 1/2"



Square nuts  
 4 X - 3/8"  
 8 X 5/16"



2 X Standard hexagonal  
 nuts 5/16"



Wing nuts

6 X - 5/16"  
 2 X - 1/4"

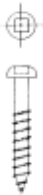

Round head screw

14 X - #12 x 1 1/2"  
 4 X - #14 x 3"

Online Video showing all stages of installation.  
 In case of differences between the video and the  
 instructions, follow the written instructions.

<https://vimeo.com/594753285/7fa105d5ac>



Tacks for canvas



2 X eye screws

1 book Warp & Weave



Nylon Spacer 1/2"

X 3



Nylon Washer 3/4"

X 2

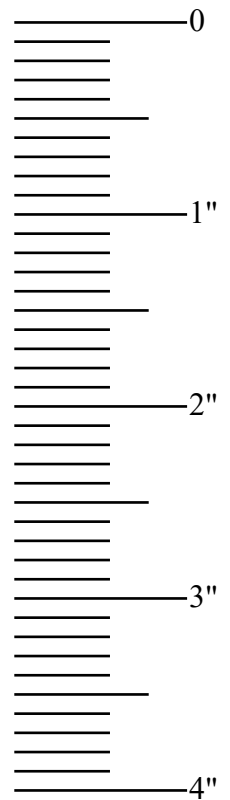

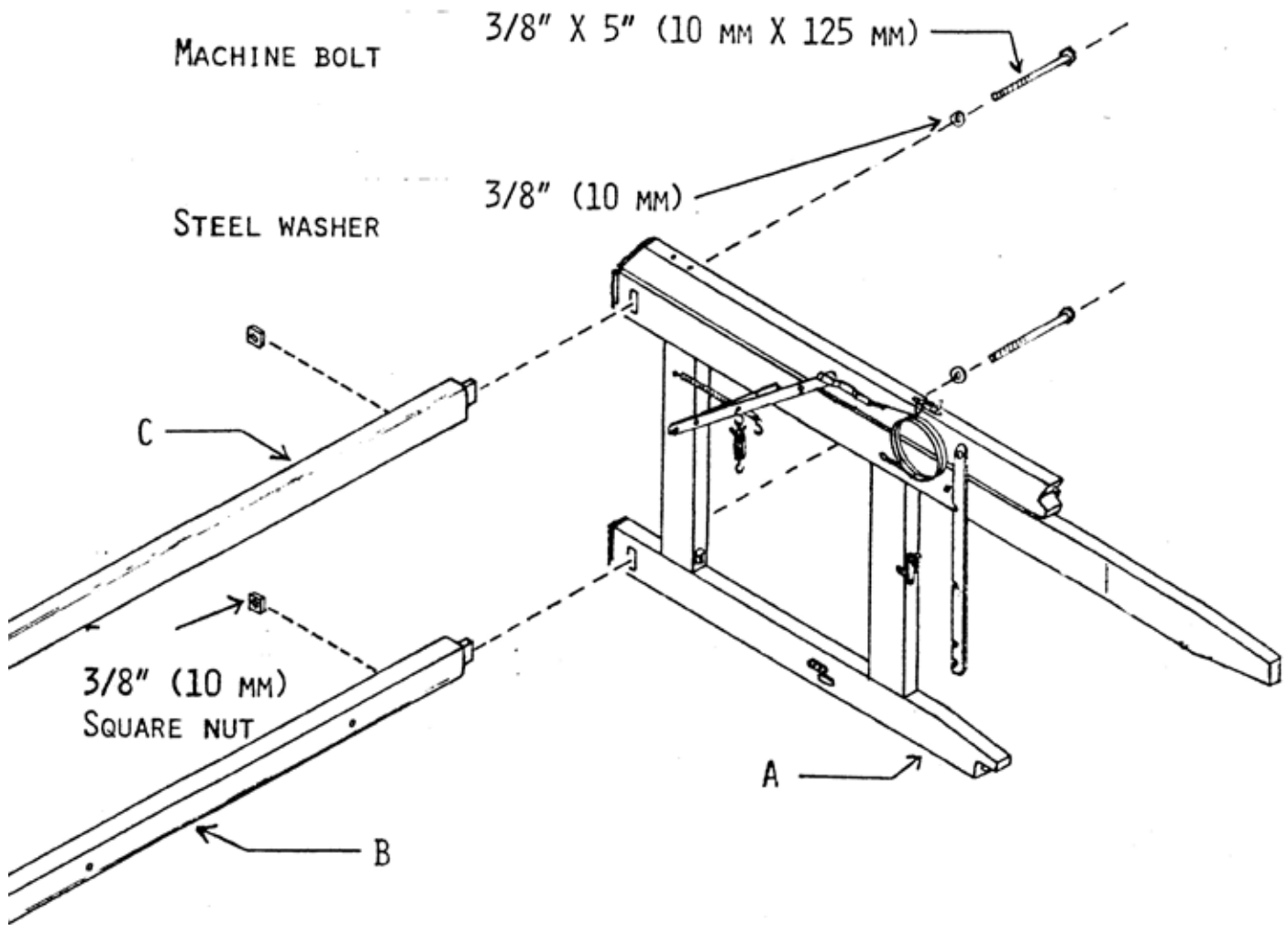

Place right-hand side A of the loom on its front.

Insert the tenon of lower cross-member B into the lower front mortise of right-hand side A.

**NOTE:**

The lower front cross-member has two holes drilled through it which are used to affix the treadle set.

Using the wrench supplied with the loom, affix cross-member B with a 3/8" x 5" machine bolt, a 3/8" steel washer and a square nut.

Repeat the sequence with cross-member C (no holes).



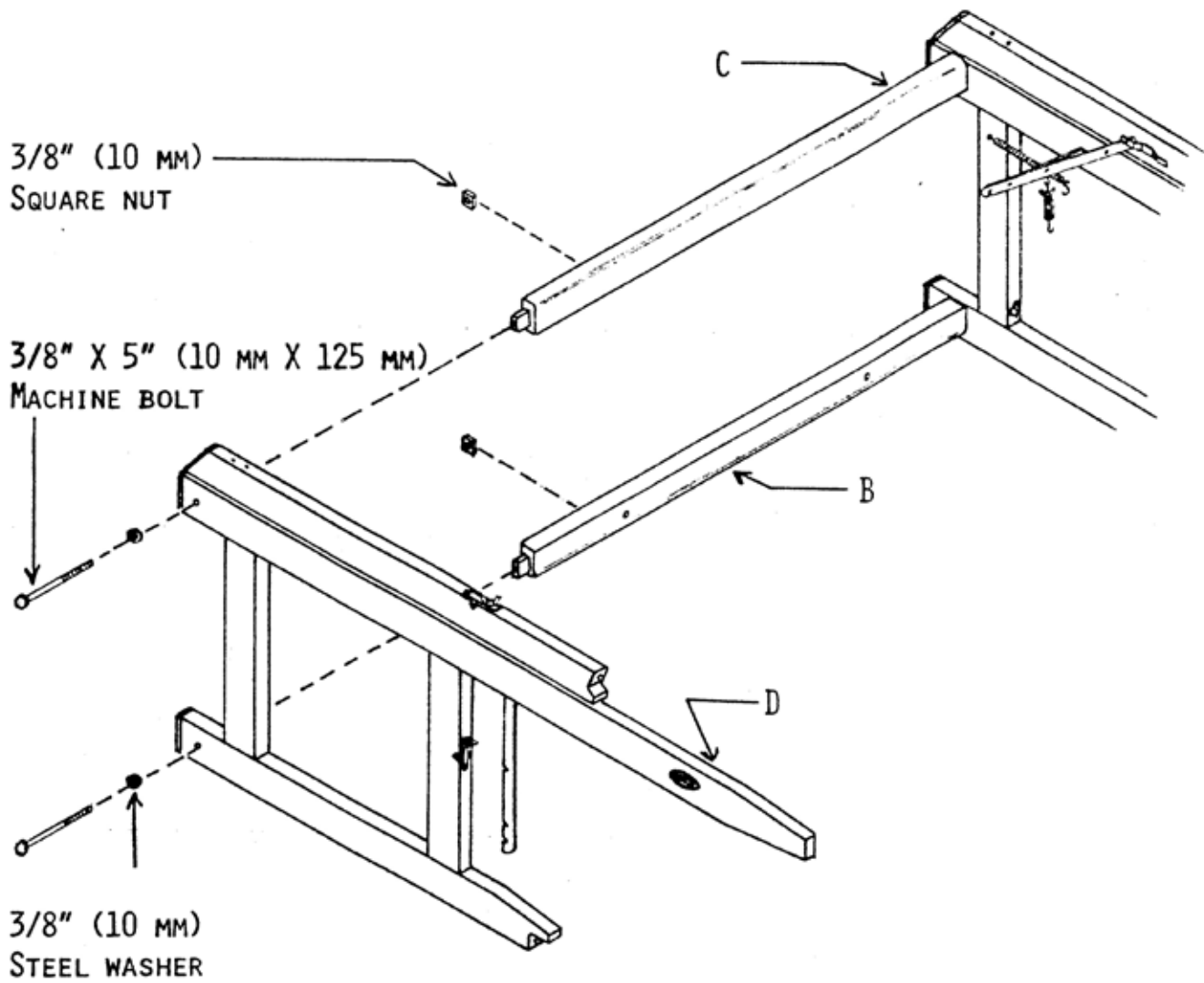

After having placed the left-hand side D of the loom on its front, repeat the previous procedure again using the same tools, same bolts, same washers and nuts.

**ATTENTION: Application of soap to the screws will make their insertion easier.**

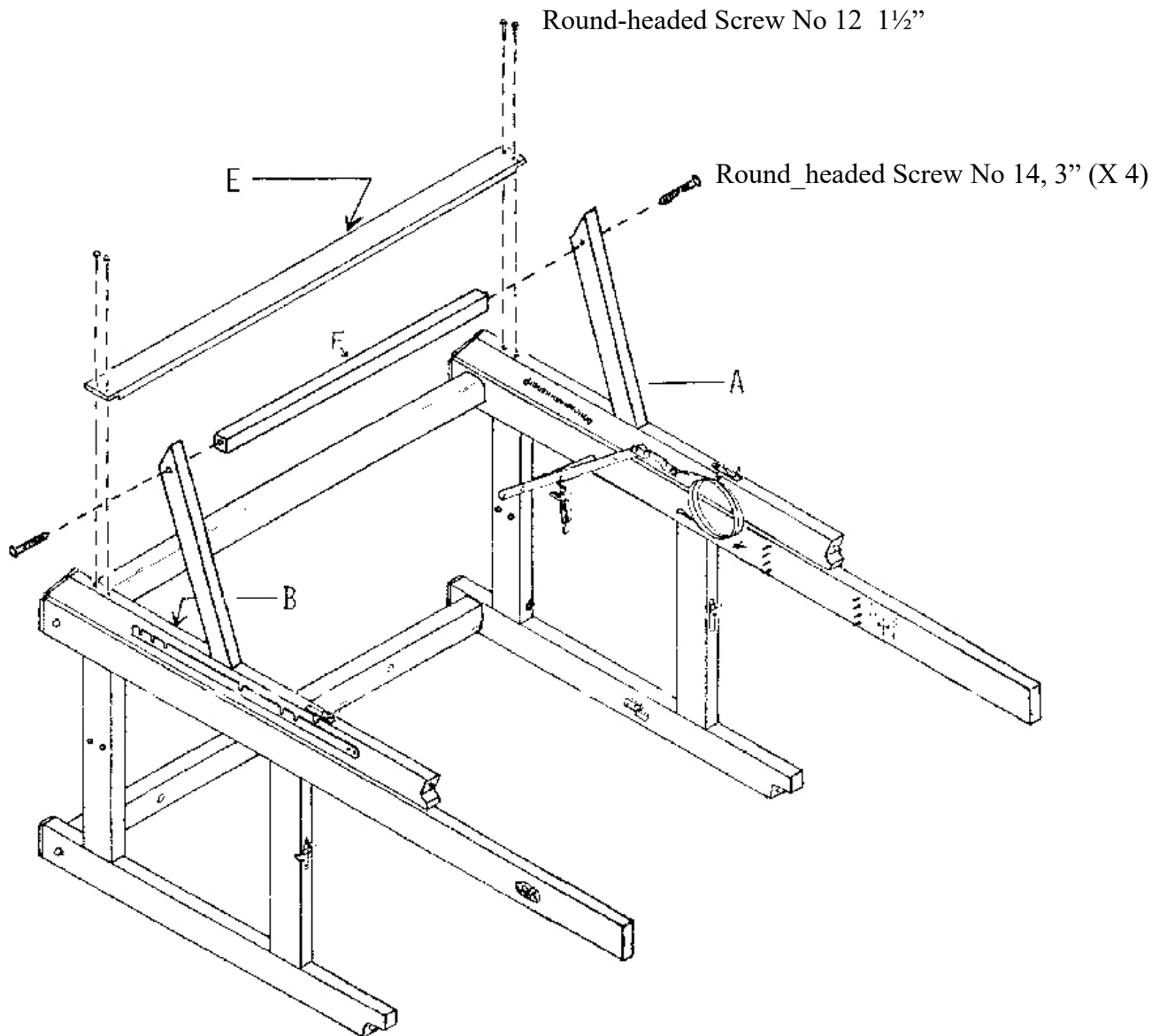

Using four 1 1/2" (40 mm) round-headed screws No 12, affix back cross-member E to back posts C and D.

**NOTE:**

If cross-member E does not fit between posts A and B, insert it higher between the posts then slide it down. Application of soap to the screws will make their insertion easier.

Using four, 4" round-headed screws No. 14, affix the cross-member F for the stabilizing posts B.

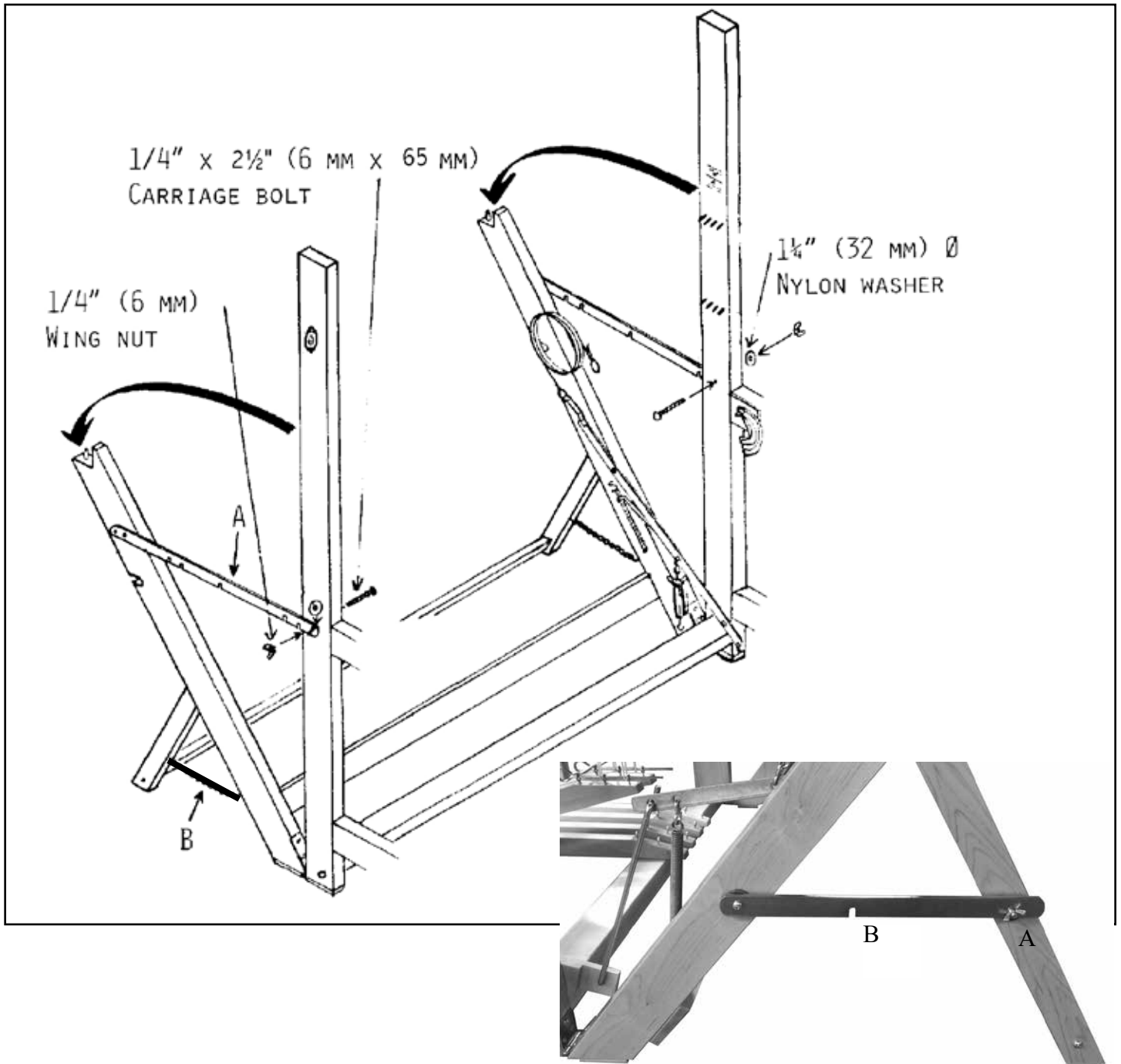

Unfold the back section of the loom and lock it in place with metal hooks A.

Insert a 1/4" x 2 1/2" carriage bolt into the holes of the uprights. The nylon washer is already installed in the upright. Fasten the bolt with a 1/4" wing nut.

Be sure that the stabilizing posts are open and flat on the floor. Insert a 1/4" x 2 1/2" carriage bolt into the holes of the stabilizing posts (A). Affix the two hooks (B) using a 1/4" wing nut.

Make sure the 2 stabilizing post (C) are flat on the floor. Insert the 1/4 "x 2 1/2" carriage bolts into the holes in the stabilizing post. Screw the 2 hooks (B) on each side and secure by tightening the 1/4 wing nuts. Complete the installation by fixing the back stabilizing cross-member (D) using the 4 X # 14 - 3" screws.

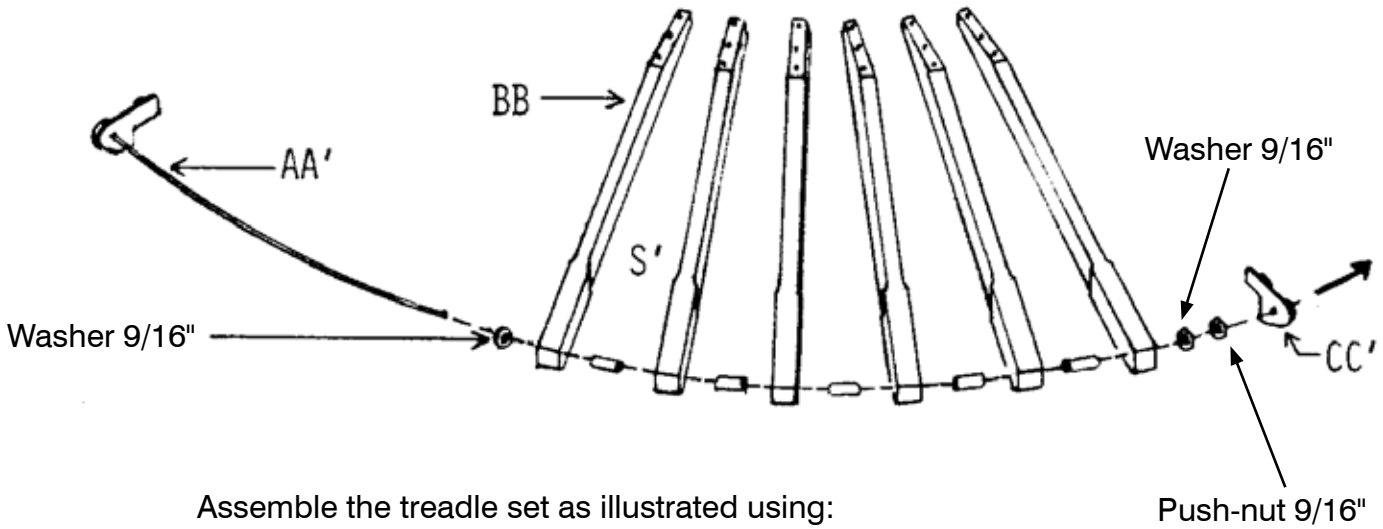
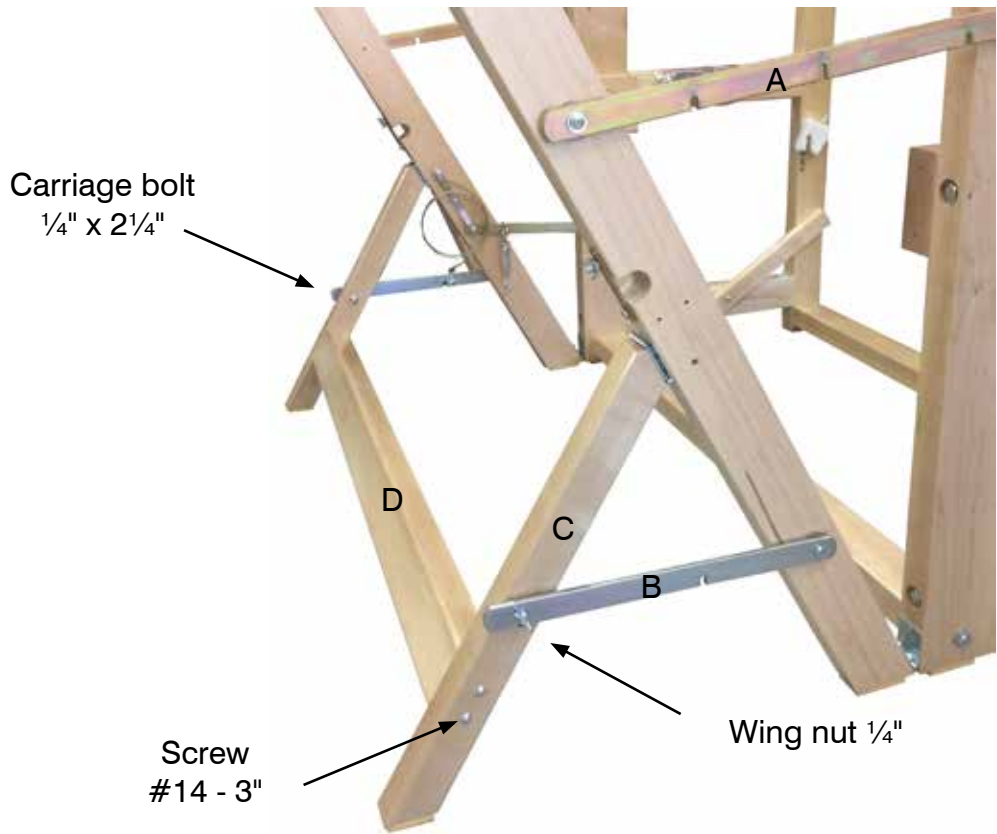

Assemble the treadle set as illustrated using:

- Treadle rod pre-assembled
- 6 x Treadles
- 5 x Wooden spacers 1 1/2"
- 2 x Steel Washers 9/16"
- 1 X Push-nut

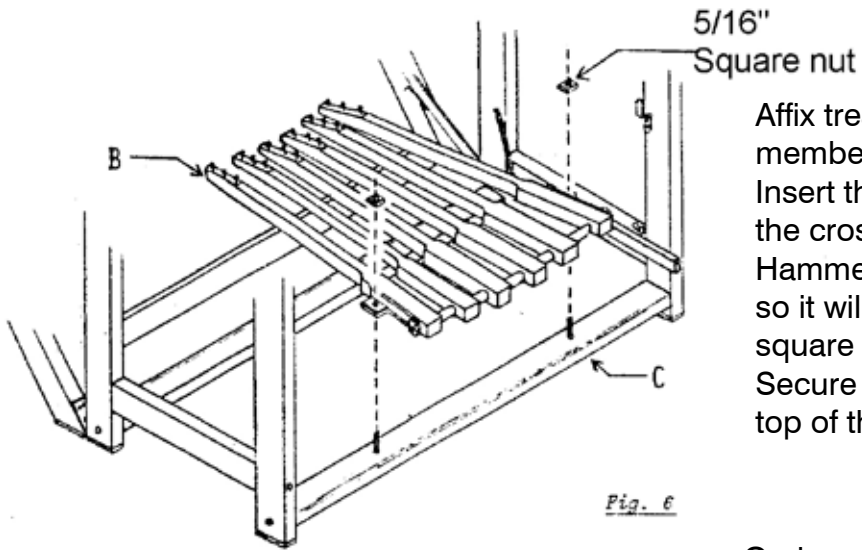

Affix treadle set B to lower front cross-member C.  
 Insert the 5/16" x 2 1/2" bolts from under the cross-member.  
 Hammer the carriage bolt inside the hole so it will lock while you will screw the square nuts.  
 Secure them with the square nuts in the top of the metal treadle support.

Fig. 6

Or; hexagonal

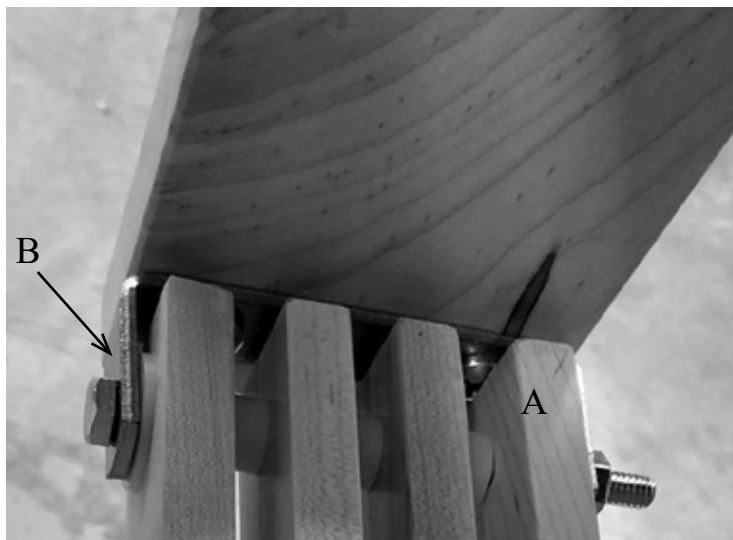

Attach the four lams (A) to the metal bracket (B) on the left center upright using a machine bolt (BO) 1/4 "X 4" and a auto-locking nut (EC) 1/4". Placed 3 nylon spacer (ES) and 2 nylon washer (RO) according to the drawing below .Tighten slightly.

NOTE: The side of the lam having a eye must be on top

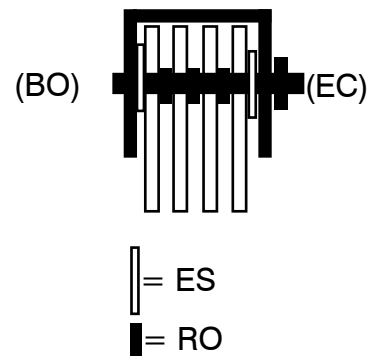
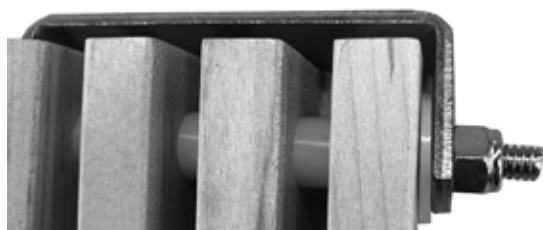

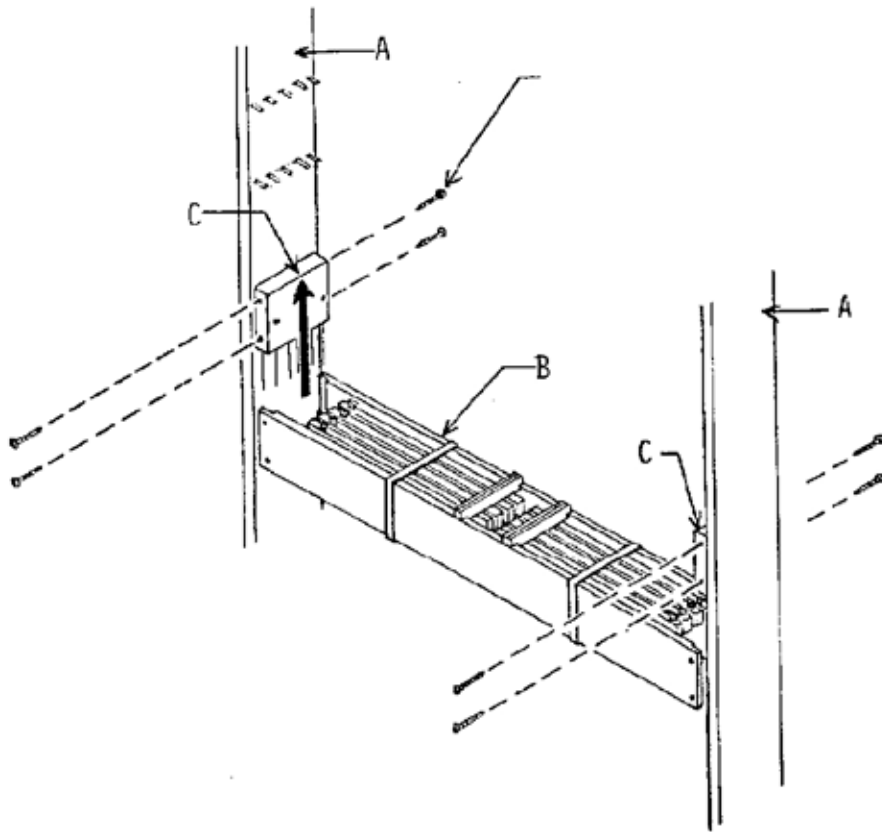

Slide jack box B along the middle posts A, from bottom to top, and affix it to blocks C using eight 1½" (40 mm) round-headed screws no. 12. (Fig. 8)

Note: the top right front hole have been drill at an angle to make the installation easier.

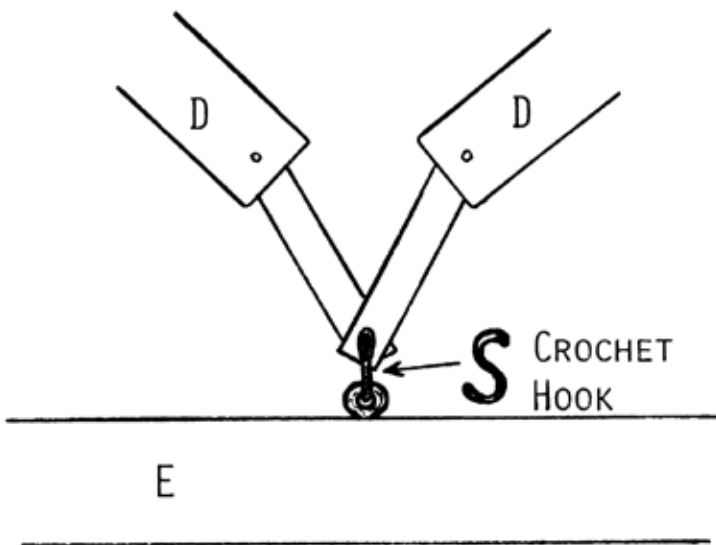

Remove Saran Wrap from the jack box and put the "S" hook of the jack D inside the eyelet of the lam E. (Fig. 9)

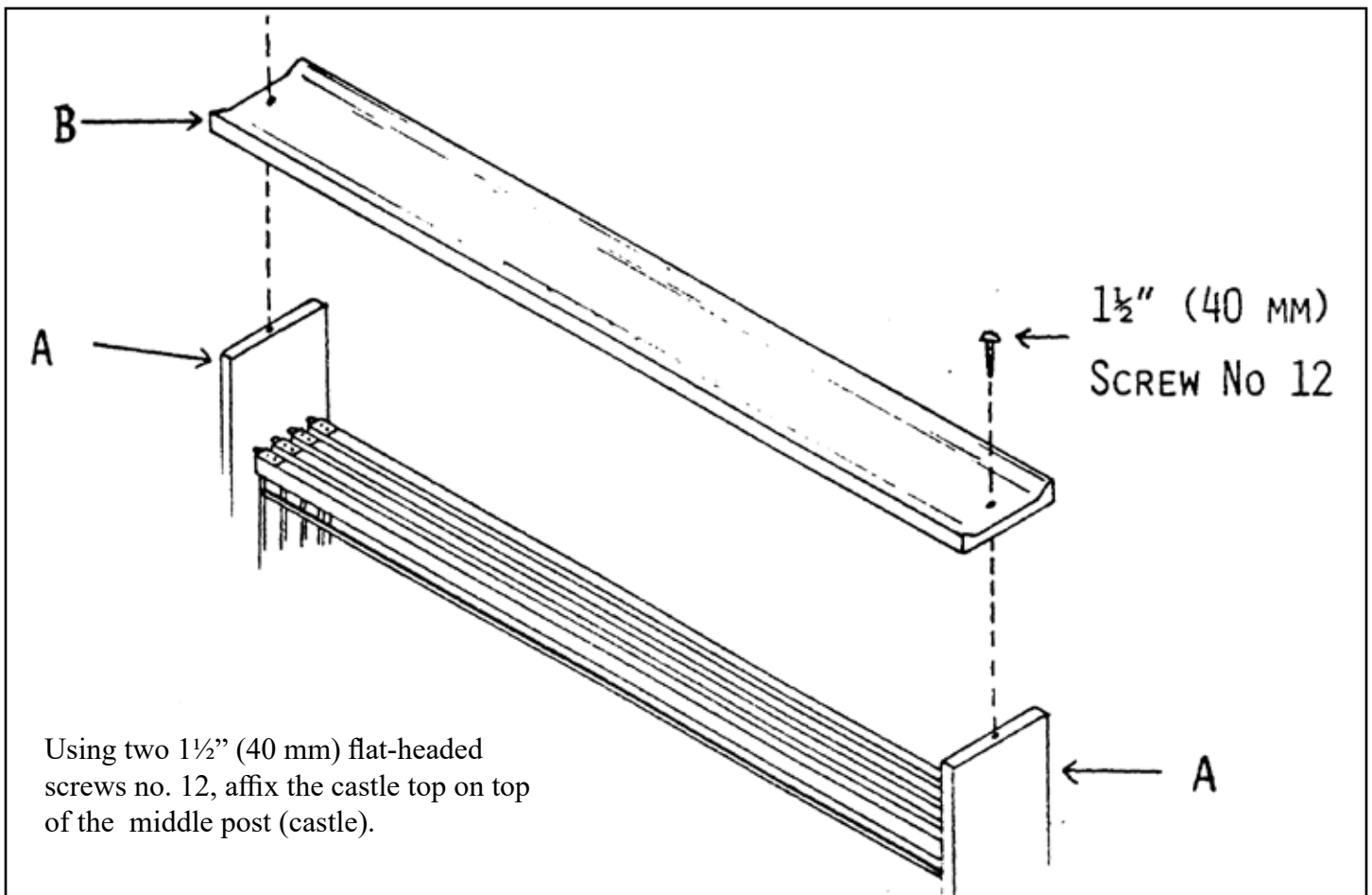
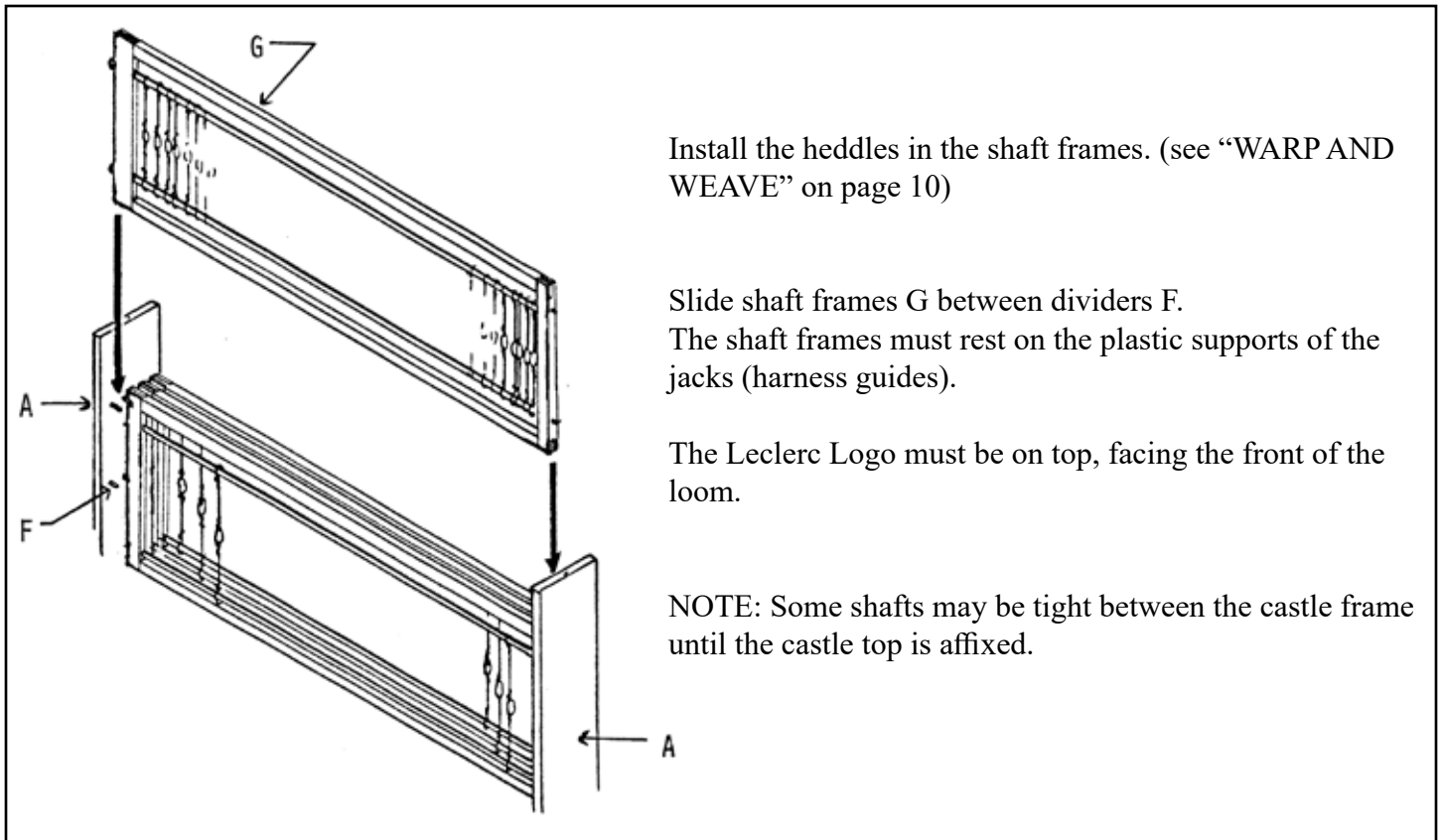

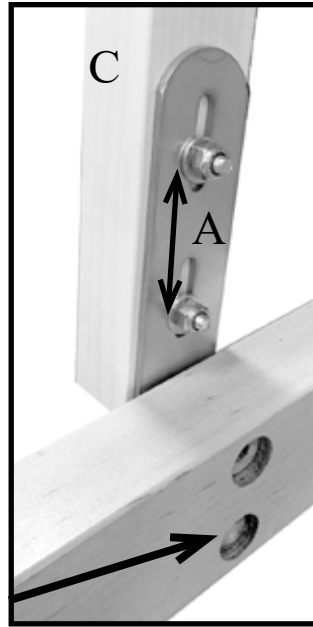
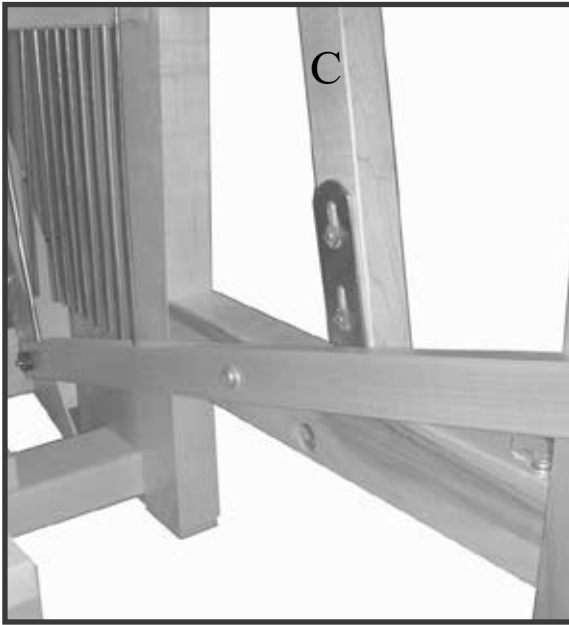

**NOTE: Hammer the head of the carriage bolt inside the hole**

Using 5/16" x 2 1/4" carriage bolts, affix swords to lower front cross-members. Insert the bolt from the inside into the **lower hole**.

- 1- Place a 5/16" steel washer between the cross-member and the sword.
- 2- Hand tight slightly the square nut 5/16"
- 3- Hand tight tighter the wing nut 5/16"

To adjust the height of the beater, loosen the autolock of the bottom of the sword (A)

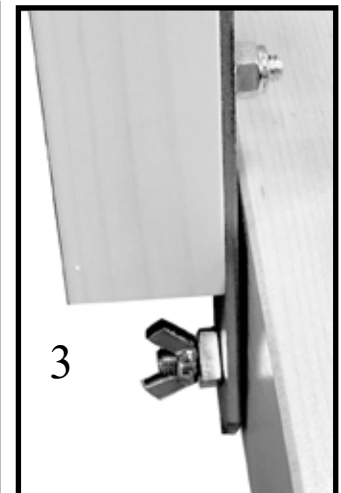
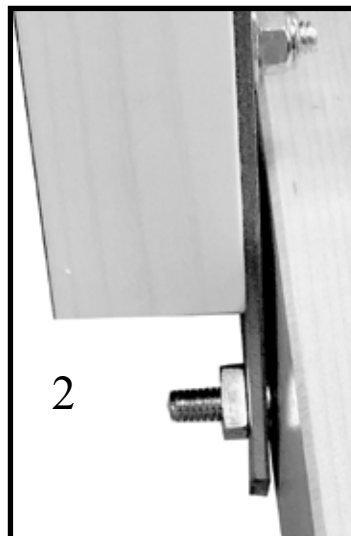



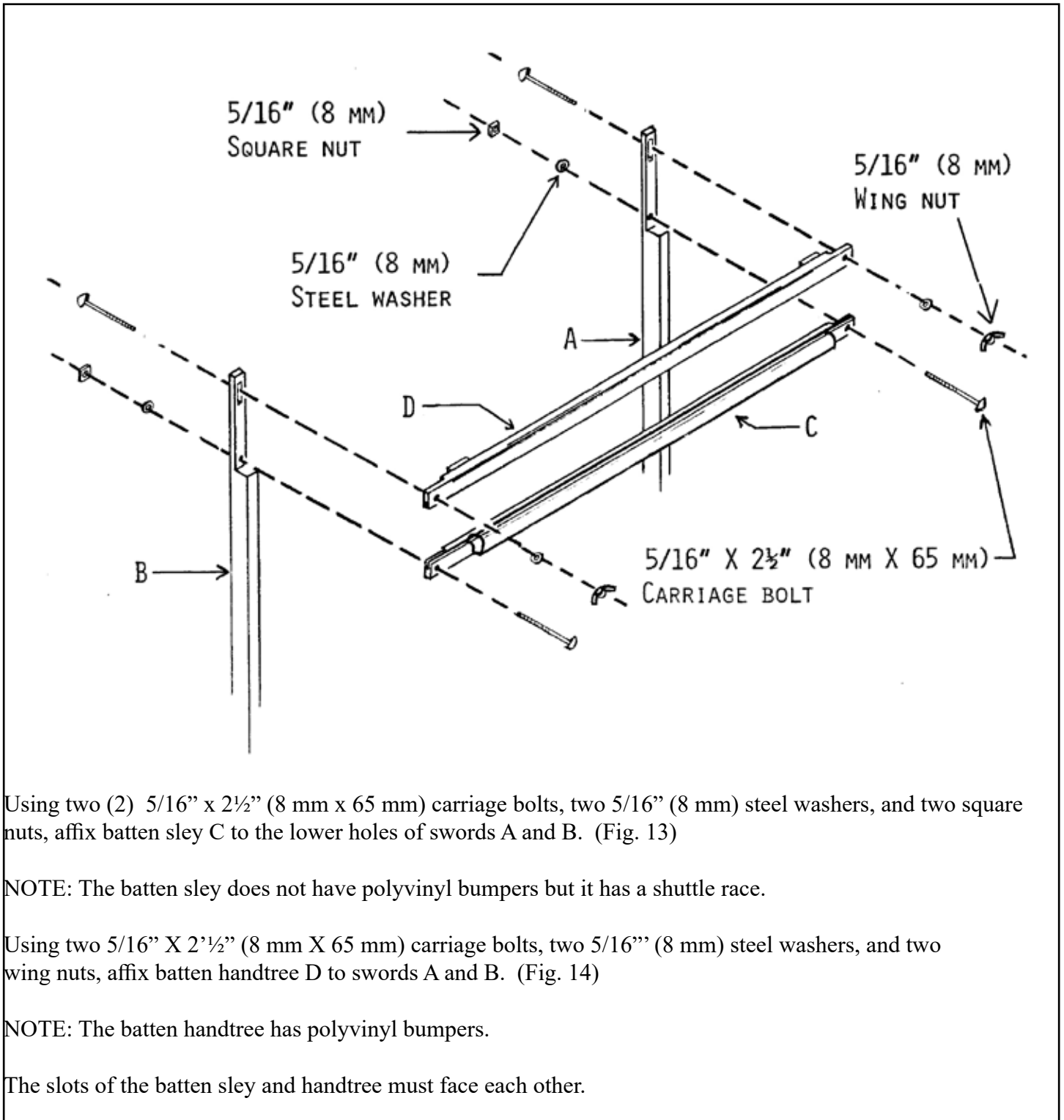

Using two (2) 5/16" x 2½" (8 mm x 65 mm) carriage bolts, two 5/16" (8 mm) steel washers, and two square nuts, affix batten sley C to the lower holes of swords A and B. (Fig. 13)

NOTE: The batten sley does not have polyvinyl bumpers but it has a shuttle race.

Using two 5/16" X 2½" (8 mm X 65 mm) carriage bolts, two 5/16" (8 mm) steel washers, and two wing nuts, affix batten handtree D to swords A and B. (Fig. 14)

NOTE: The batten handtree has polyvinyl bumpers.

The slots of the batten sley and handtree must face each other.

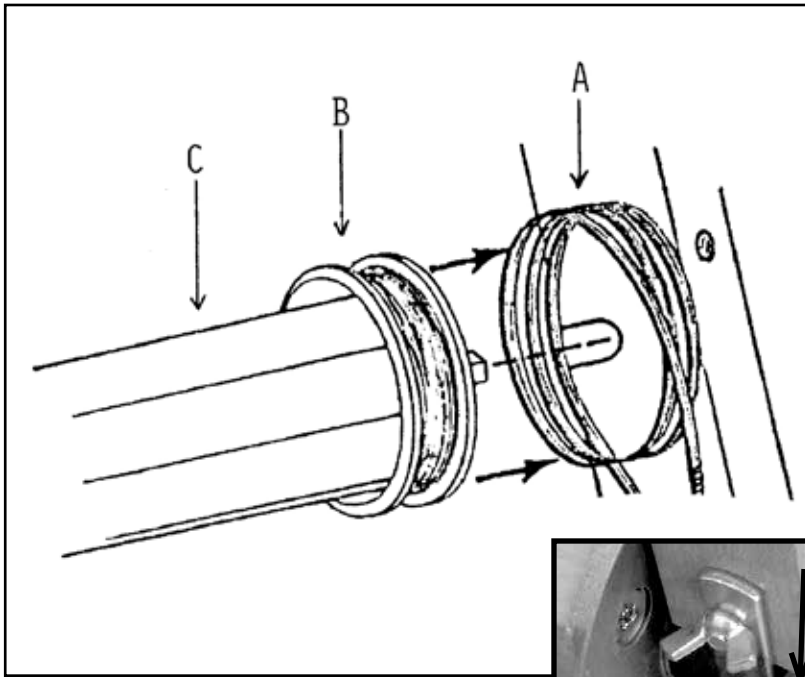

## WARP BEAM INSTALLATION

Hold the circular wire brake shoe A slightly to the rear of the loom, **but do not unroll it.**

Insert the brake drum B into the wire brake shoe A. Then, install the ends of the warp beam C into the grooves of the back posts.

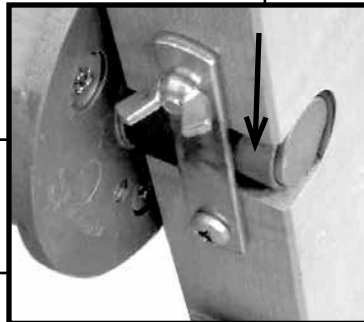

In order to improve the rotation of the warp beam, special bushings are supplied. Make sure to leave them in place when installing the warp beam on the loom.

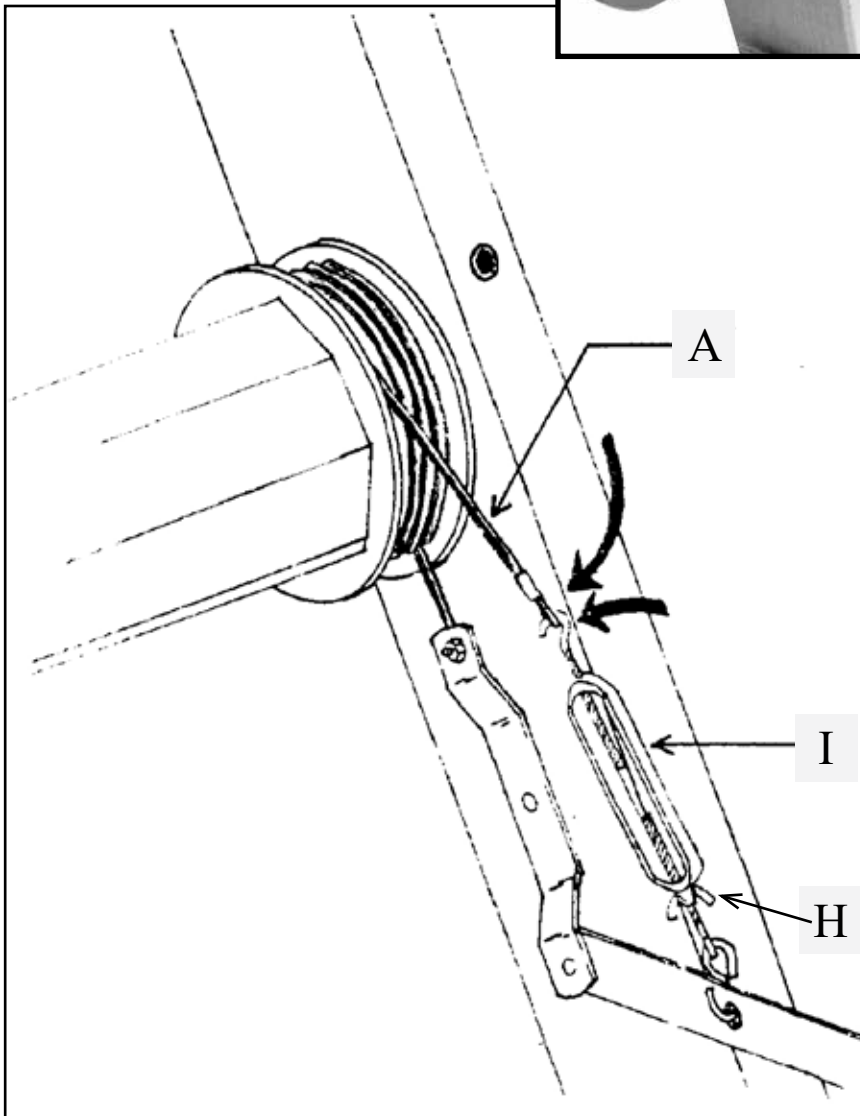

Hook turnbuckle I to flat wire circle A.

### BRAKE ADJUSTMENT:

Release the brake by depressing the brake treadle and locking it down with the catch G.

The warp beam should turn freely but the brake circle should not be too slack. If the tension is too great, unscrew the wing nut H slightly and then loosen the turnbuckle I. If the tension is too slack or the beam is turning counterclockwise (while standing on the brake side of the loom), tighten the turnbuckle I slightly and then the wing nut H.

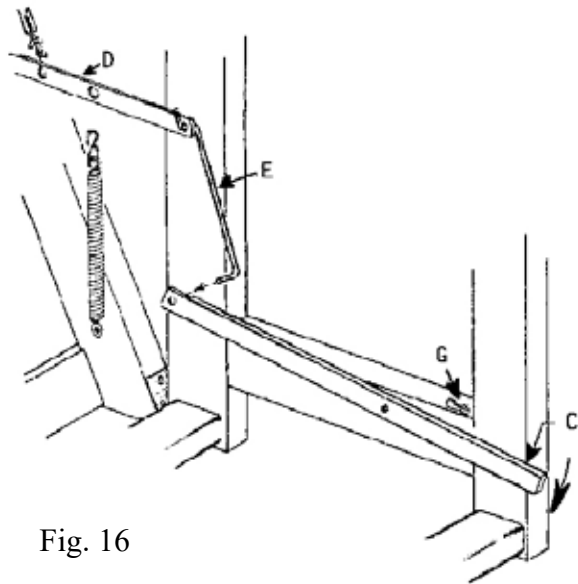

Fig. 16

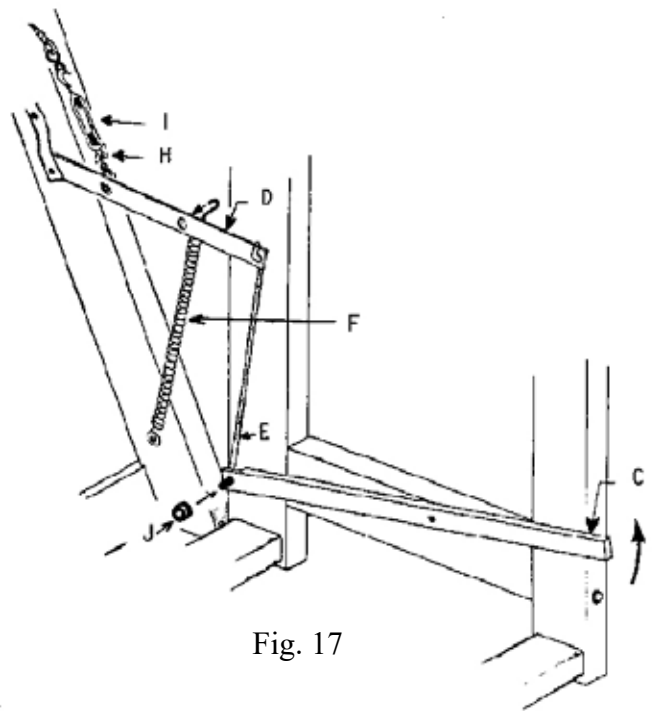

Fig. 17

Using metal rod E, join treadle C to lever D. First insert the double-cornered end of the metal rod into lever D; then insert the other end of the metal rod into treadle C while the treadle is depressed. (Fig. 16)

Raise treadle (back part) C as high as possible then hook spring F to lever D. (Fig. 17)

#### BRAKE ADJUSTMENT:

Release the brake by depressing treadle C and locking it down with the catch G. (Fig. 16) The warp beam should turn freely but the circular brake wire should not be too slack. If the tension is too great, unscrew the wing nut H slightly and then loosen the turnbuckle I. If the tension is too slack, tighten the turnbuckle I slightly and then the wing nut H. (Fig. 17)

Insert the black rubber ring J to the lower end of the rod E, to prevent the rod from slipping out. (Fig. 17)

#### **BEAMING**

*Release the brake by depressing the brake treadle (C) and locking it down with catch (G).*

#### **WEAVING**

*To advance the warp, depress brake treadle (C) and turn cloth beam (H) at the same time. Then, release brake treadle (C) (engaging the brake) and advance the cloth beam until the desired tension is achieved.*

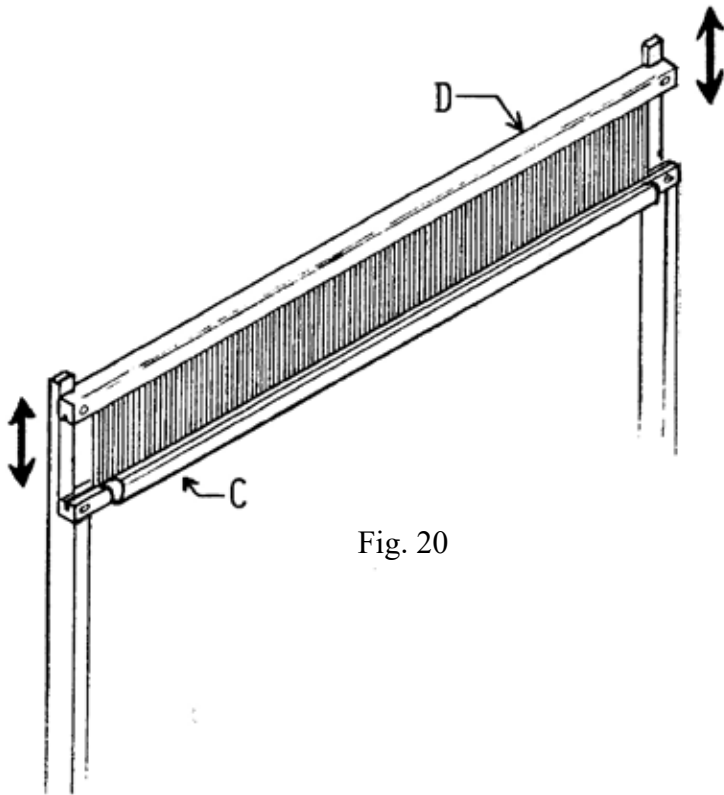
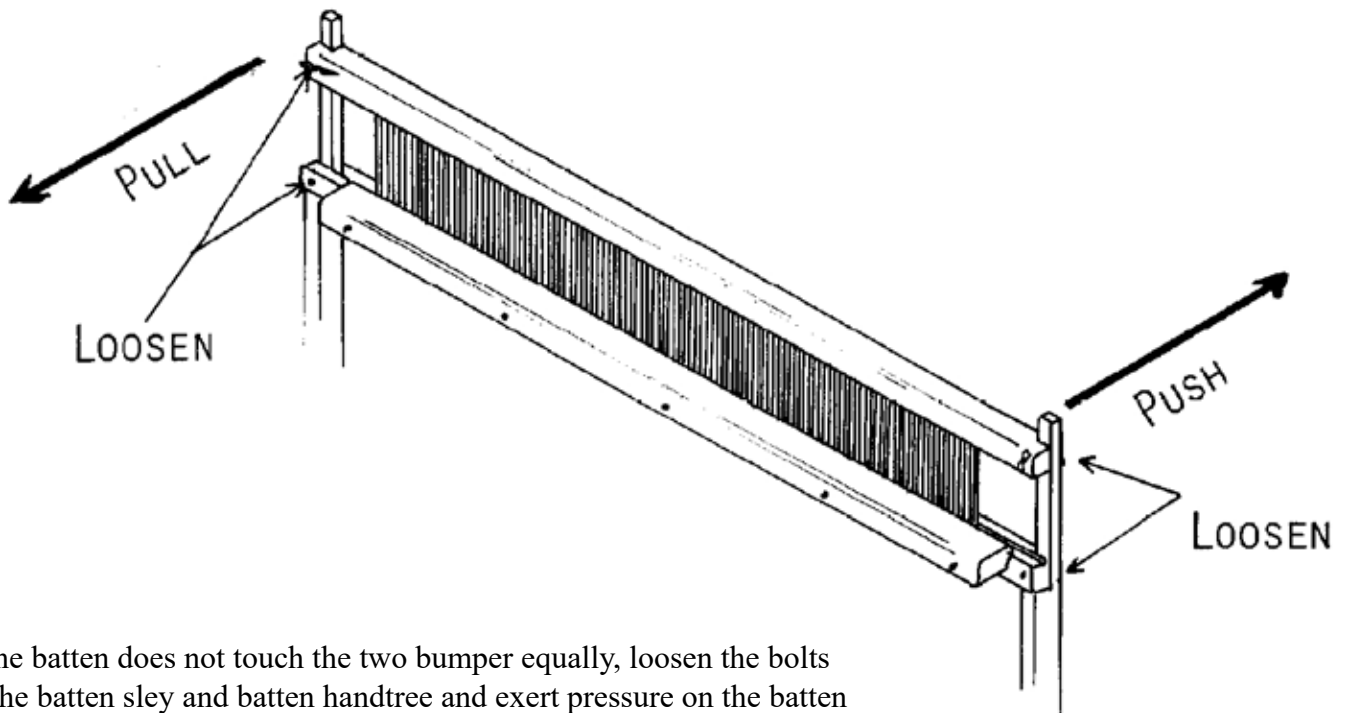

Fig. 20

Place the reed between batten sley C and handtree D. (Fig. 20)  
 When the wing nuts are loose, the batten handtree can slide vertically in the sword slots. The reed must then be secured between the batten sley and handtree by tightening the wing nuts. If the batten does not touch the two bumpers equally, loosen the bolts of the batten sley and handtree and exert pressure on the batten centering it in its proper place. Tighten the bolts again.



If the batten does not touch the two bumper equally, loosen the bolts of the batten sley and batten handtree and exert pressure on the batten centering it in its proper place. Tighten the bolts again while keeping pressure in the batten.

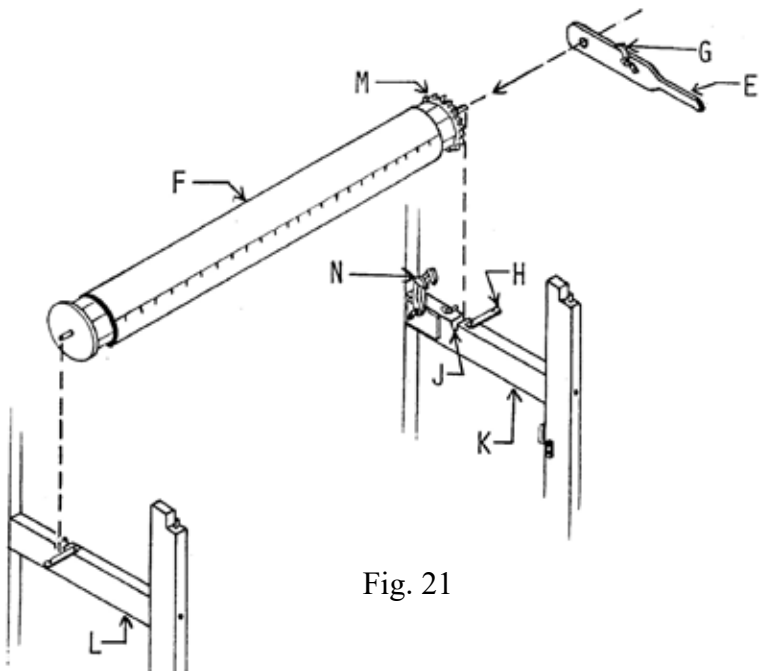
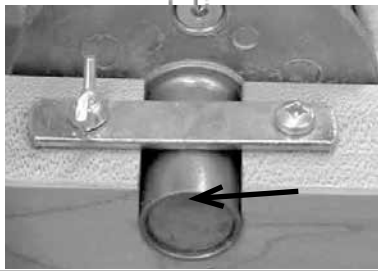

Fig. 21

Install take-up motion handle E on the axle end of cloth beam F (on the same side as the ratchet gear). Ratchet pawl G of the take-up motion handle must be lifted up. (Fig. 21)

Open beam latches H and place the beam ends in the slots J of the upper side cross-members K and L. (Fig. 21)

Note: Ratchet gear M must be on the right-hand side and ratchet pawls N must be lifted up.



In order to improve the rotation of the cloth beam, special bushings are supplied. Make sure to leave them in place when installing the cloth beam on the loom.

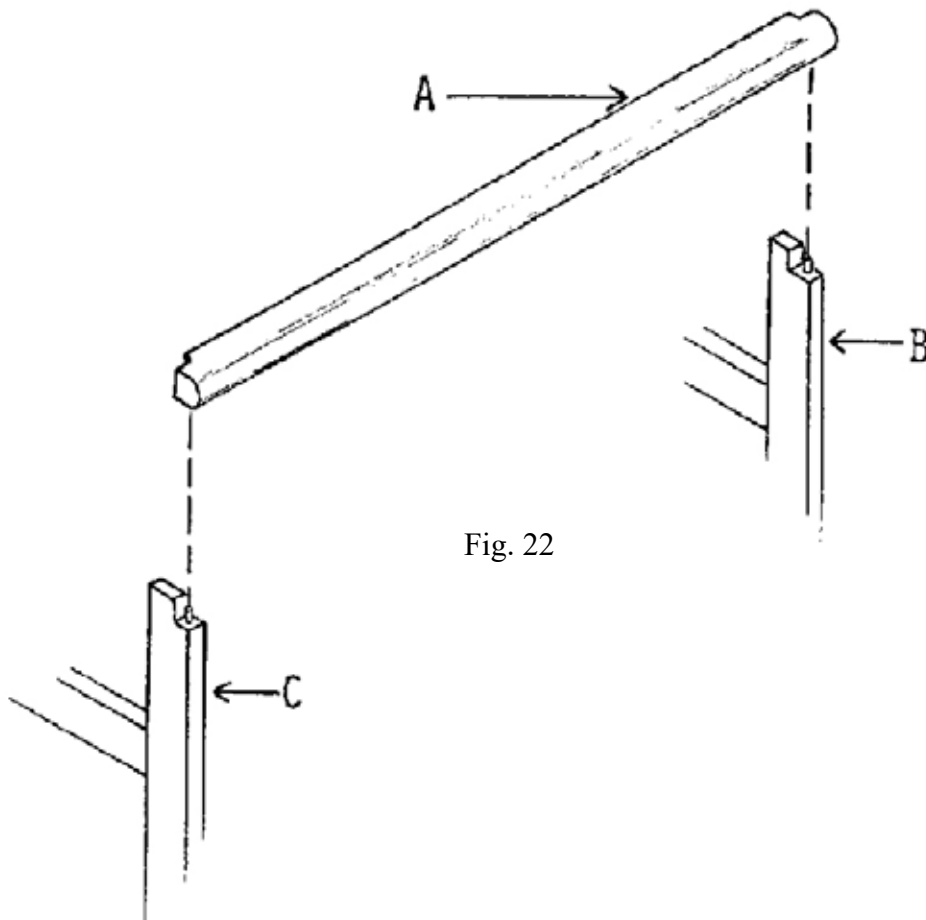

Fig. 22

Affix one of the breast beams A on the top of the front posts B and C. (Fig. 22)

Affix the other breast beam on top of the back posts.

NOTE: To avoid splitting the front posts, slightly insert the breast beam onto the metal pin. Be sure that it is in the right position before inserting it completely.

**CAUTION: Be careful when removing the front or rear breast beams of the loom. After lifting on one side, be careful not to lift it too much or move it forward or backward before lifting the opposite side. Moving it even an inch too much can cause wood to crack and it can not be repaired.**

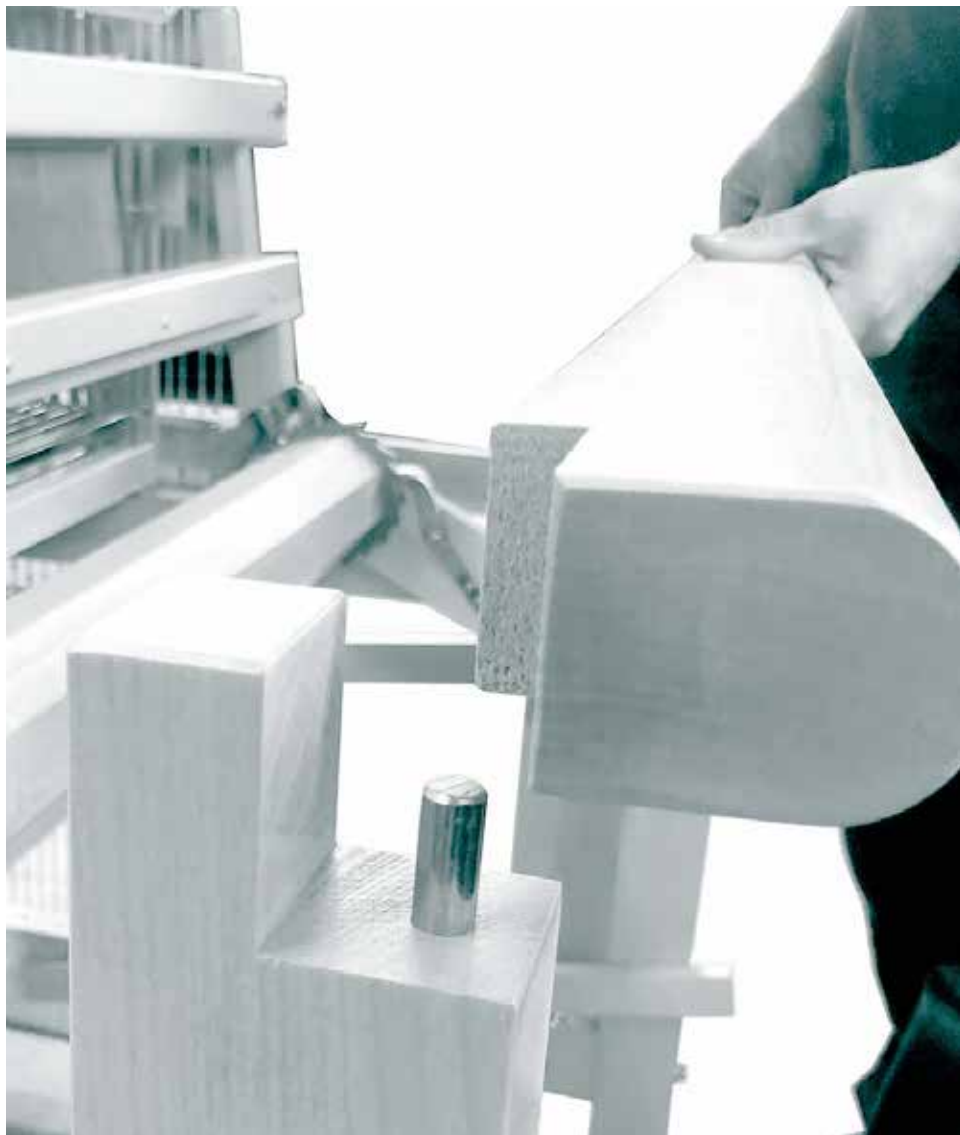

## FOLDING LOOM AND BEAMING:

Release the brake by depressing treadle C and by locking it down with catch G. Release the 4 metal hooks and fold the back of the loom.

## WEAVING:

To advance the warp, depress brake treadle C and turn cloth beam H at the same time. Then release brake treadle C and advance the cloth beam until the next notch in the ratchet gear is reached.

If this is too much tension, gently depress the brake treadle until the desired tension is obtained.

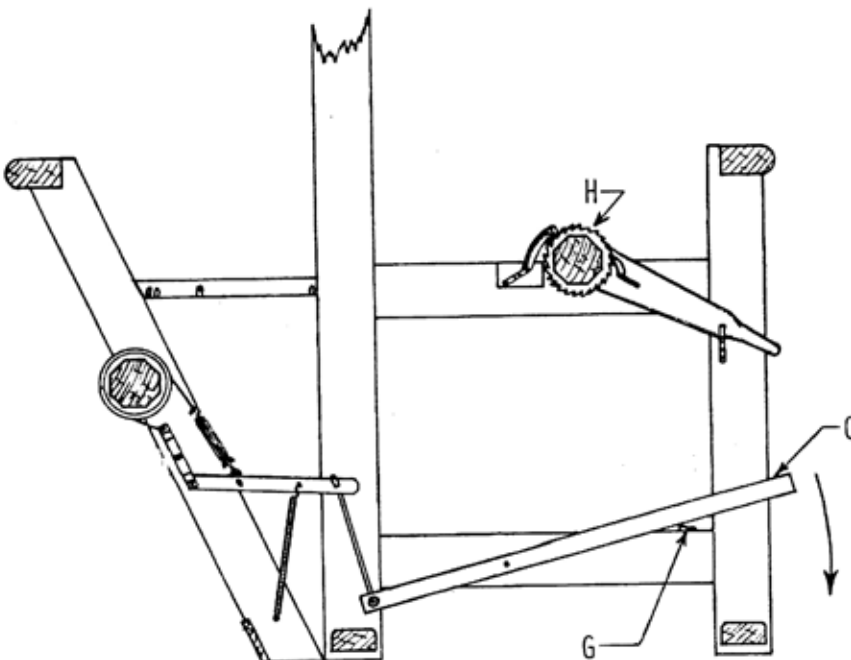

### Note while winding a warp with a Leclerc Friction Brake

To maintain proper adjustment and operation of your Friction Brake, it is recommended that the Brake be disengaged while winding the Warp.

On those looms designed with a Treadle or Lever Lock, the Brake should be locked open when winding.

### MORE INFORMATION:

See "WARP AND WEAVE"

Install the Warp beam advance control system. This system will eliminate excessive warp yarn advance when releasing the brake system at cloth take-up. This friction system is adjustable and have to be released when winding the warp on. Just screw the wing nut to increase the friction or unscrew it to release.

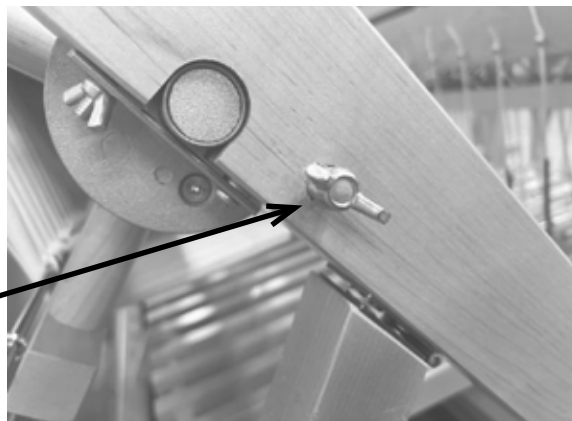

### FIRST TREADLE TIE-UP

Select any treadle and tie the Lams to the Treadles using the 7" cords supplied with the loom. Take the threading hook to help pass the cord through each hole of the lam.

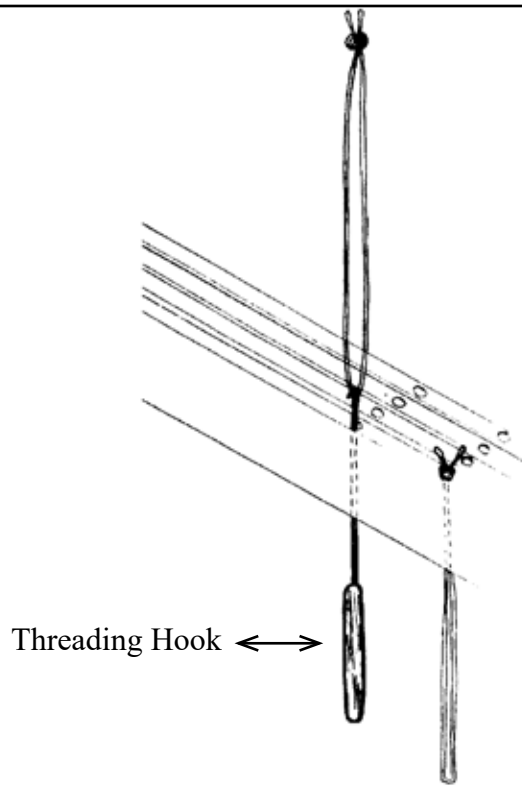

Slide the Treadle Hook through the Screw Eyes and Cord Loops.

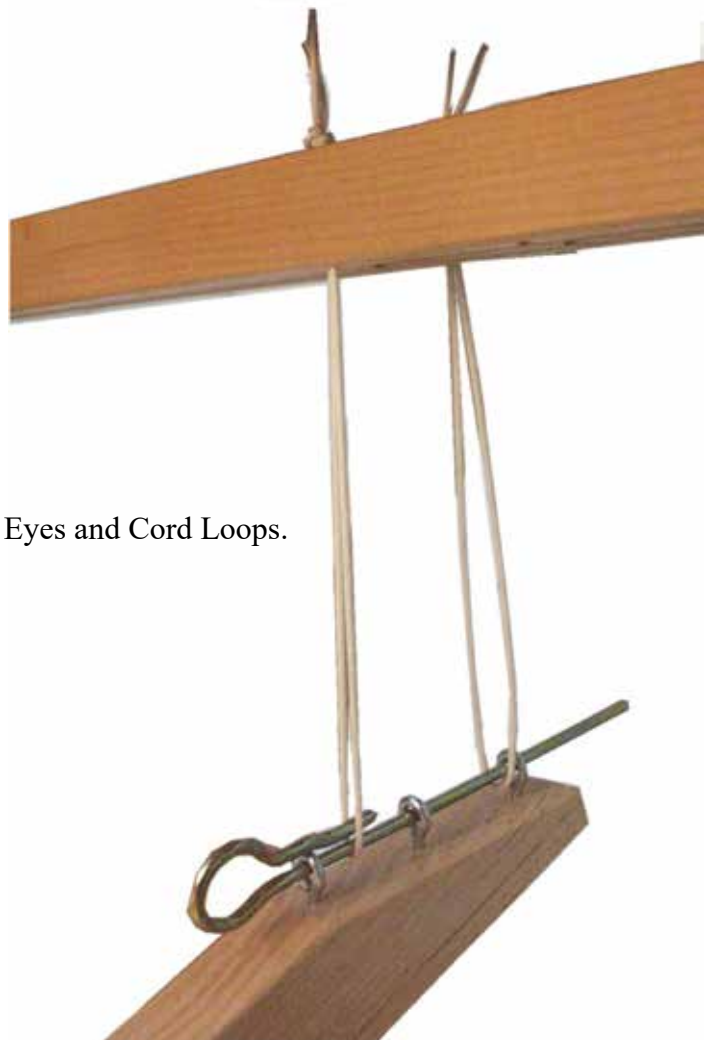
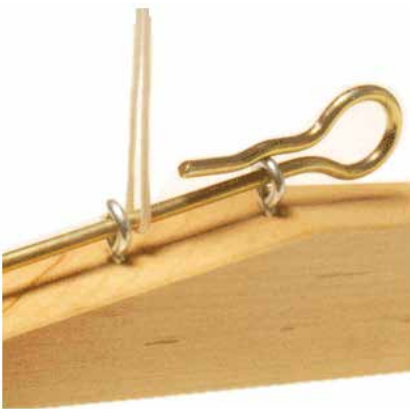



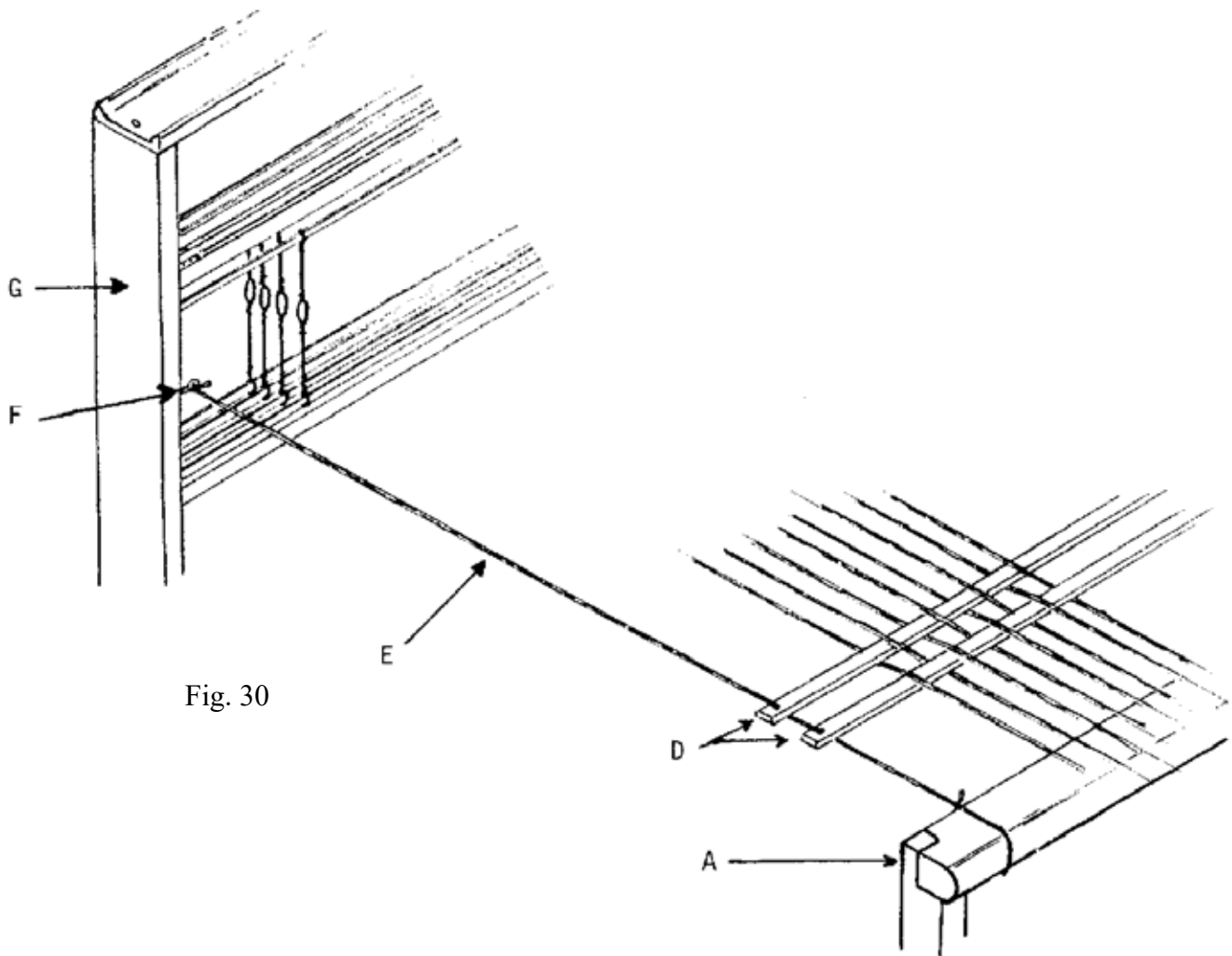
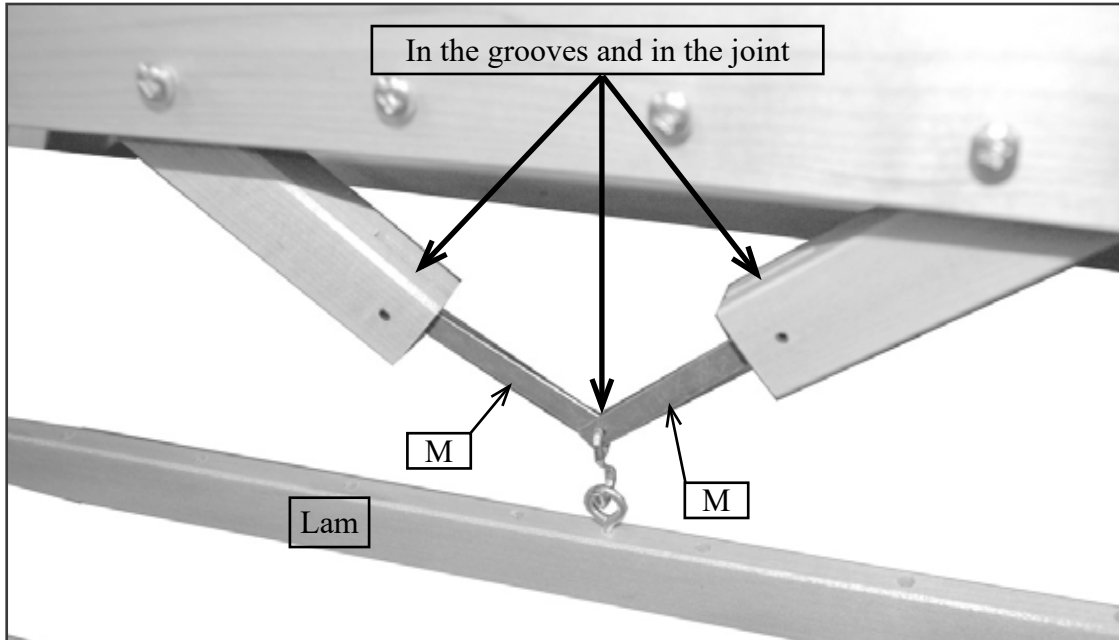

Fig. 30

Affix screw eyes F to the holes inside middle posts G.

Pass a string C through the holes at each side of the lease sticks D and tie them to the screw eyes and to the thread beam A. The lease sticks will be held at the right height and distance for easy threading. (Fig. 30)

All jack type Leclerc Looms.  
Instructions on how to keep your loom in good working condition



The friction between the metal pieces M, the spring pin of the jacks and the S Hook may produce unpleasant noise that can be eliminated by spraying silicone spray in the indicated area.

We recommend using only 100% silicone products. No oil or grease.

Suggested Silicone spray:



If the loom is equipped with a sectional warp beam, affix the rake-like pieces (following the instructions supplied with the sectional warp beam) and do the following instructions on the cloth beam only.

If the loom is not equipped with a sectional warp beam, affix the apron to the warp beam with tacks and do the following procedures on the warp and cloth beams.

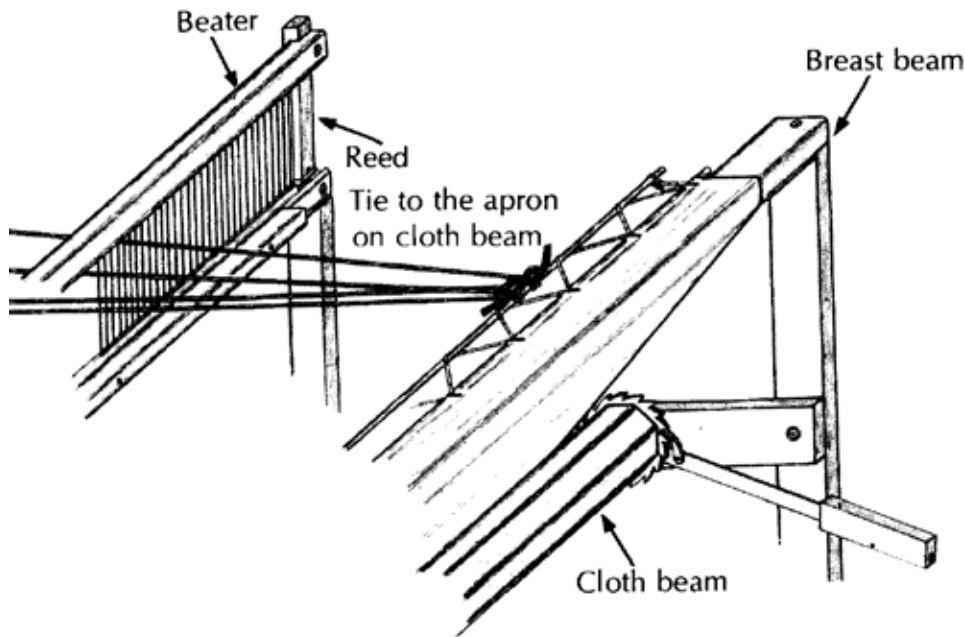

Insert a warp rod into the apron border.

For 27", 36" and 45" loom  
(70cm, 90cm and 115cm)

For 60" loom  
(150cm)

Cut the 5 yard (4.5m) cord in half.  
Use one half of the cord to lace the apron warp rod to a second warp rod. This second warp rod will be used to attach warp threads.

Use a 5 yard (4.5m) cord to lace the apron warp rod to a second warp rod. This second warp rod will be used to attach warp threads.

**We at Leclerc encourage Weaver feedback on  
this and all our products. Please  
send your comments to Leclerc Loom Co.  
[info@leclerclooms.com](mailto:info@leclerclooms.com)**

**HAPPY WEAVING**