

# Leclerc Looms

Since 1876



1573 Savoie  
C. P. 4 Plessisville, Qc.  
G6L 2Y6  
TEL: 819-362-7207  
FAX: 819-362-2045  
www.leclerclooms.com  
info@leclerclooms.com

## NILUS 8 SHAFTS JACK-TYPE LOOM WITH BACK HINGE TREADLE

36"	1025-3628
45"	1025-4528
60"	1025-6028

On receiving the loom, unpack and lay out the loom components.  
Do NOT discard any packing material until all parts are inventoried.

Check the parts received against the parts list on pages #2 to #7 of the assembly instructions. Report any discrepancies to Leclerc immediately.

To assemble this loom, a minimum of 2 people are needed but it is recommended you use 3.



Loom Prepared by: \_\_\_\_\_

Inspected by: \_\_\_\_\_

Date: \_\_\_\_\_

# PARTS LIST

1 right-hand side

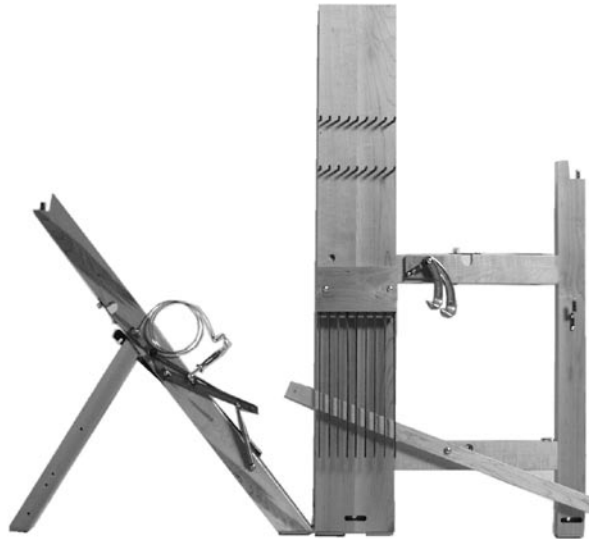

1 left-hand side

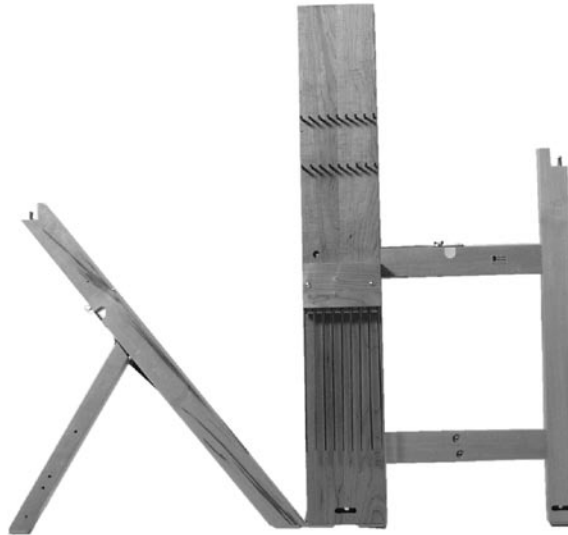

Note for Leclerc in French : Faire les petit trous dans les montants pour les baguettes d'encroix.  
Mettre les bloc de boîte à marmousets.

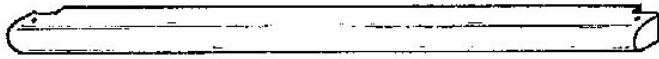

2 breast beams  
(43½", 52 5/8", 68 1/8")

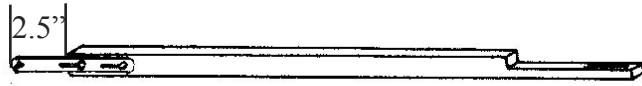

32½"

1 left sword



1 right sword

Vérifier que les bagues entre bien dans les pattes et traverses

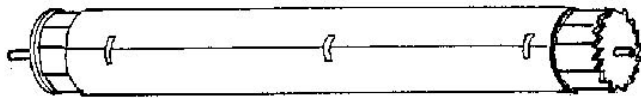

1 cloth (front) beam  
(38½", 47 5/8", 62 9/16")

Avec Bagues (Bushings)

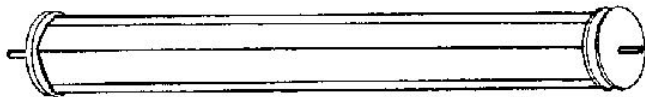

1 warp (back) beam  
(38½", 47 5/8", 62 9/16")

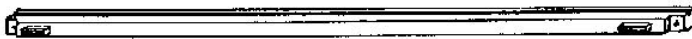

1 batten handtree  
(46¾", 55¾", 70¾")



1 batten sley with shuttle race  
(46¾", 55¾", 70¾")

No holes across

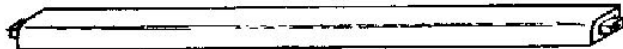

1 Front cross-member  
(40½", 49", 64")

2 small holes in the top

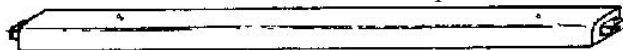

1 Middle set cross-member  
(40½", 49", 64")

3 holes for treadle set 26½" CC

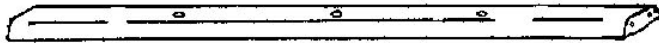

1 Back cross-member connecting  
stabilizing posts

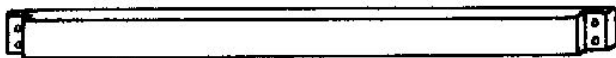

1 cross-board connecting the back  
posts (34½", 52 5/8½", 67 1/4")



1 apron

LECLERC NOTE:  
Avec la rondelle de bois



1 cloth take-up motion handle

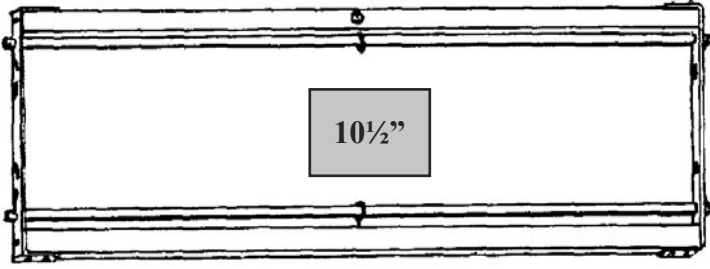

8 shaft frames

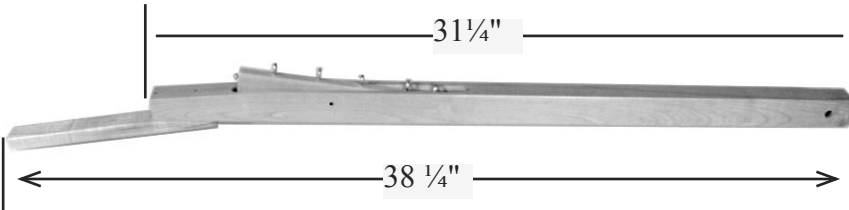

10 treadles with extension



3 treadle supports



1 treadle set rod 28 3/4" with one pushnut



1 more Treadle set Pushnut



1 treadle separator

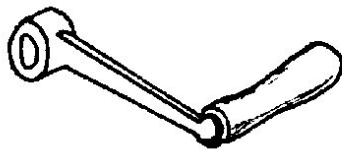

1 Crank

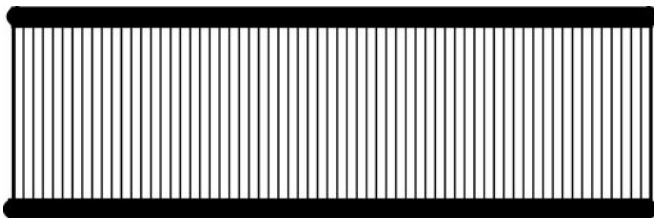

1 reed



2 lease sticks



4 warp rods  
+ 2 Heavy rods for narrow fabric 4



3 screwdrivers (Black, Red and Green)



1 aluminum wrench



1 adjustable wrench

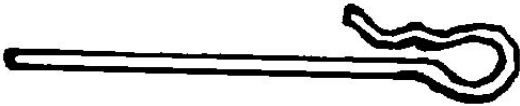

1 set of 10 treadle hooks 10" # 3500-4521



5 sets of 12 treadle cords 6"

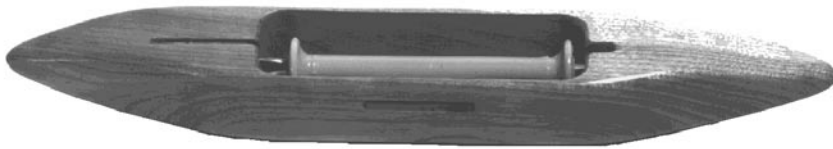

1 boat shuttle



12 plastic bobbins

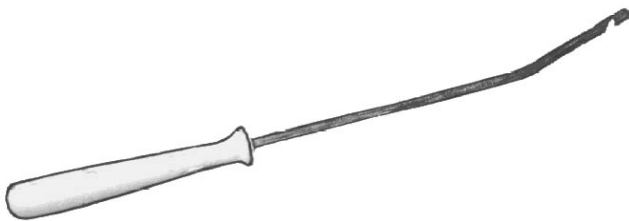

1 threading hook



2 pkg of cords (5 yds each)

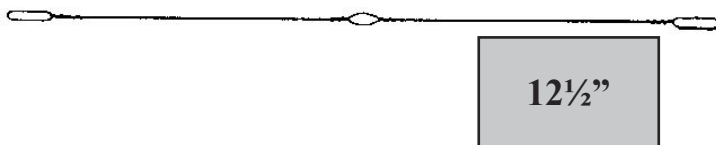

1000 heddles (36" loom)  
1200 heddles (45" loom)  
1500 heddles (60" loom)

8 FLOATING LAMS

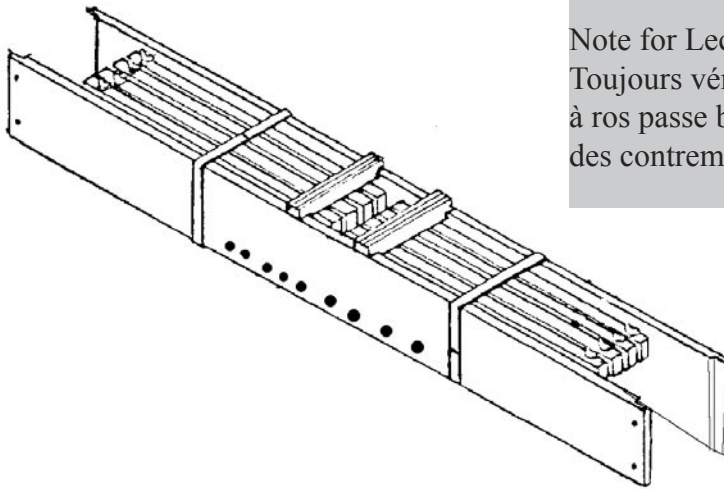
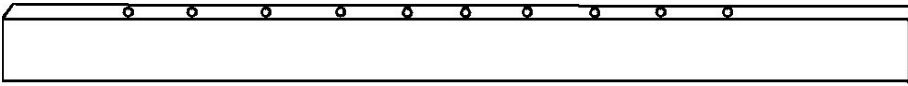

Note for Leclerc in French :  
Toujours vérifier si le crochet  
à ros passe bien dans les trous  
des contremarches.

1 BOX JACKS  
(8jacks)

**Do not remove saran wrap  
before the unit is installed  
on the loom.**

The springs and the rod is warp  
with the jack box.

NOTE: The springs and the rod are warp with the jack box



10 springs with 6½”  
loop cord  
(9½” overall)

Note for Leclerc in French:  
Emballer la tige et les ressorts avec la boîte à marmousset

-----  
*Refaire le trou sup. droit de la planche à angle.*



1 Metal rod for spring  
kit

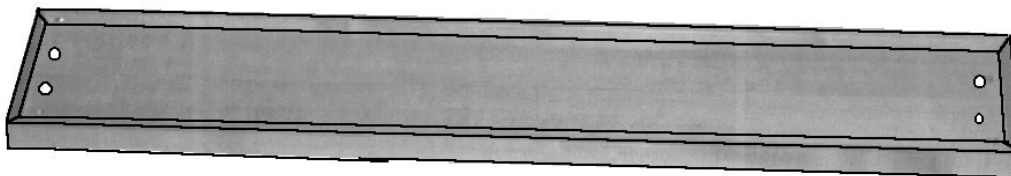

1 CASTLE TOP  
36”=41 5/8”  
45”= 50 ¾”  
60”= 65 15/16”



1 warp beam  
advance control  
system  
2 vis no 12, 1”

Note: Faire les avant trous sur la patte

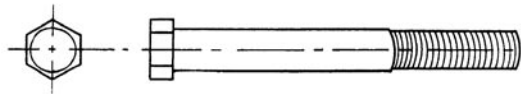

Machine bolts  
4X - 3/8" x 5"

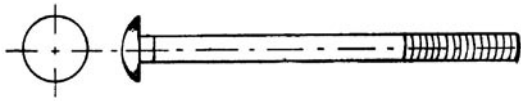

Carriage Bolts  
4X - 1/4" x 2 1/4"  
4X - 5/16 x 2 1/2" (back hooks)  
3X - 5/16" x 4"  
2X - 5/16" x 2 1/4"



11X - 5/16"  
4X - 9/16" (treadle set)  
4X - 3/8"



HEXAGON NUTS  
2X- Nylon auto lock 5/16"

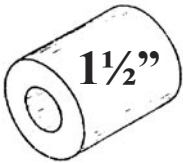

Wooden spacer  
4X for a 4 shaft loom  
8X for a 8 shaft loom



SQUARE NUTS  
4X - 3/8"  
5X 5/16"



Wing nuts  
2 X - 1/4" (6 mm)  
5X - 5/16" (8 mm)



Round head screw  
4X - #12 x 1 1/2"  
8X - #12 x 1 1/2" (jack box)  
4X - #14 x 3" (treadle set)  
2X - #8 x 1 1/2" (Treadle separator)



Flat head screw  
4X - #12 X 1 1/2" (38 mm)  
(castle top)



2X eye screws



Tacks for canvas



10 Loop cords 18 1/2" long for treadle rocker

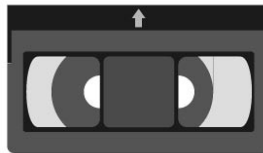

1 VHS instruction Video showing all stages of installation.

WARP AND WEAVE

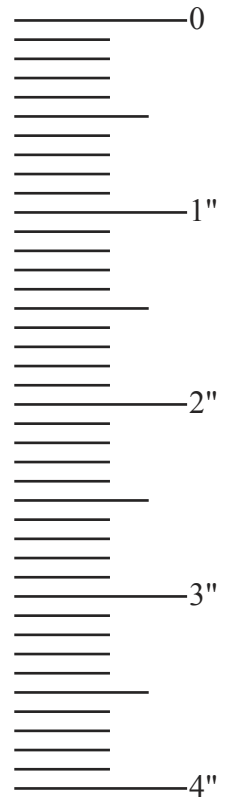

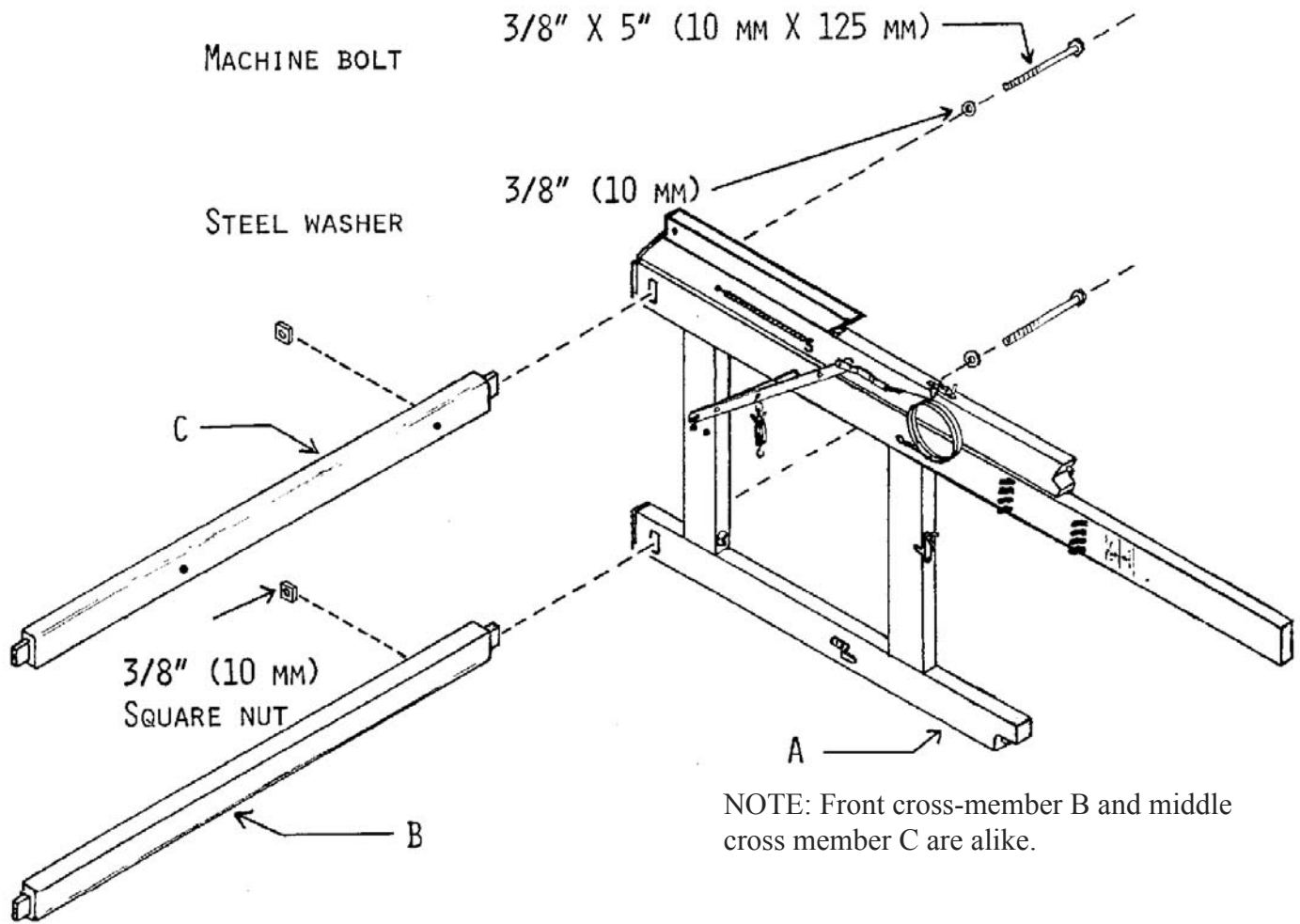

Fig. 1

Place right-hand side A of the loom on its front.

Insert a tenon of lower front cross-member B into the lower front mortise of right-hand side A. (Fig. 1)

NOTE: The lower front cross-member B does not have holes drilled through it

Using the wrench supplied with the loom, affix cross-member B with a 3/8" X 5" (10 mm X 125 mm) machine bolt, a 3/8" (10 mm) steel washer, and a square nut. (Fig. 1)

Insert a tenon of lower back cross-member C into the lower back mortise of right-hand side A. (Fig. 1)

NOTE: The lower back cross-member C does have 2 small holes drilled through it.

Affix cross-member C with a 3/8" X 5" (10 mm X 125 mm) machine bolt, a 3/8" (10 mm) steel washer, and a square nut (Fig. 1)



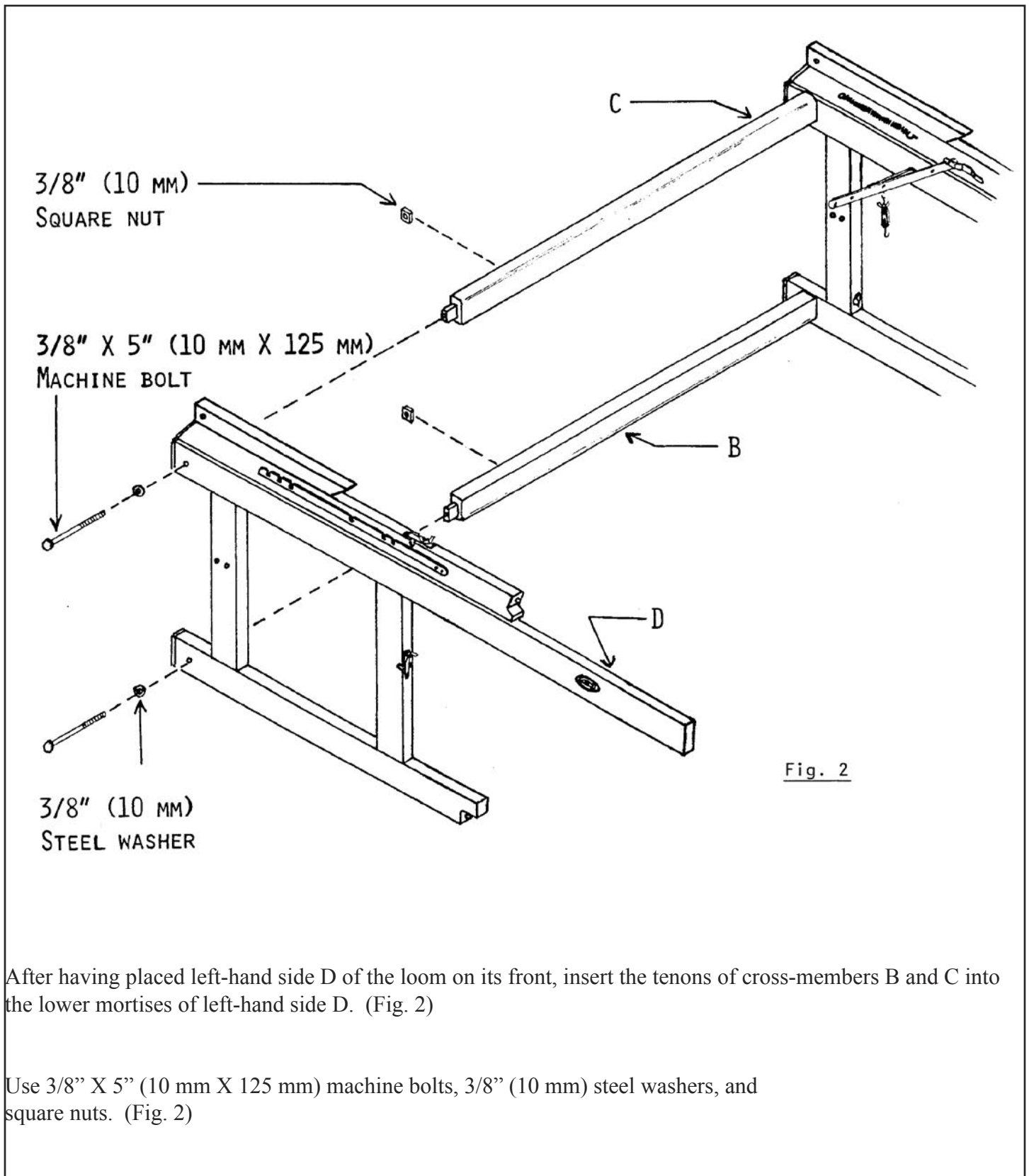

**ATTENTION: Application of soap to the screws will make their insertion easier.**

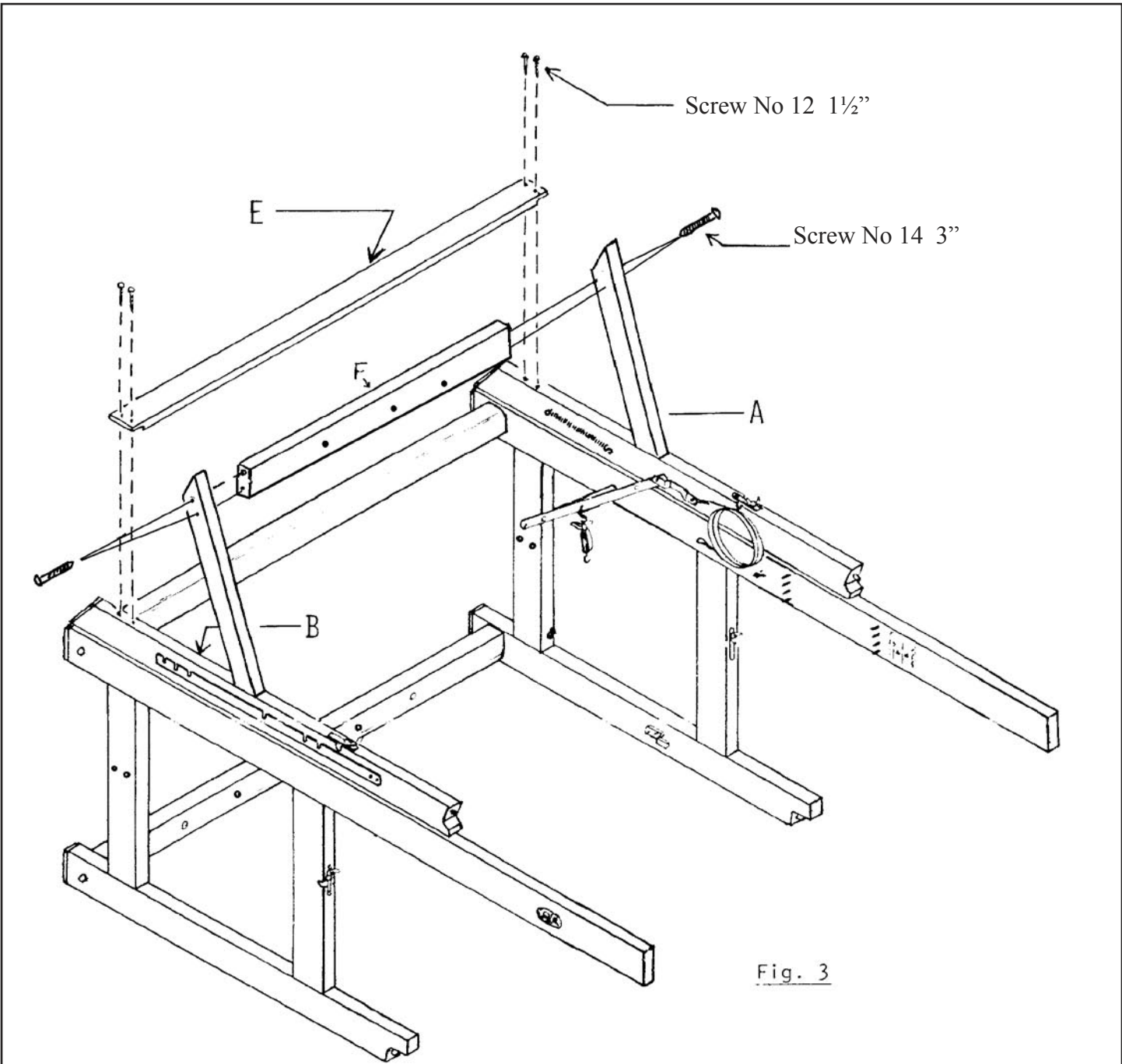

Fig. 3

Using four 1 1/2" (40 mm) round-headed screws No 12, affix back cross-member E to back posts A and B. (Fig. 3)

Using four 2 1/2" round-headed screws No. 14, affix the treadle cross-member F.

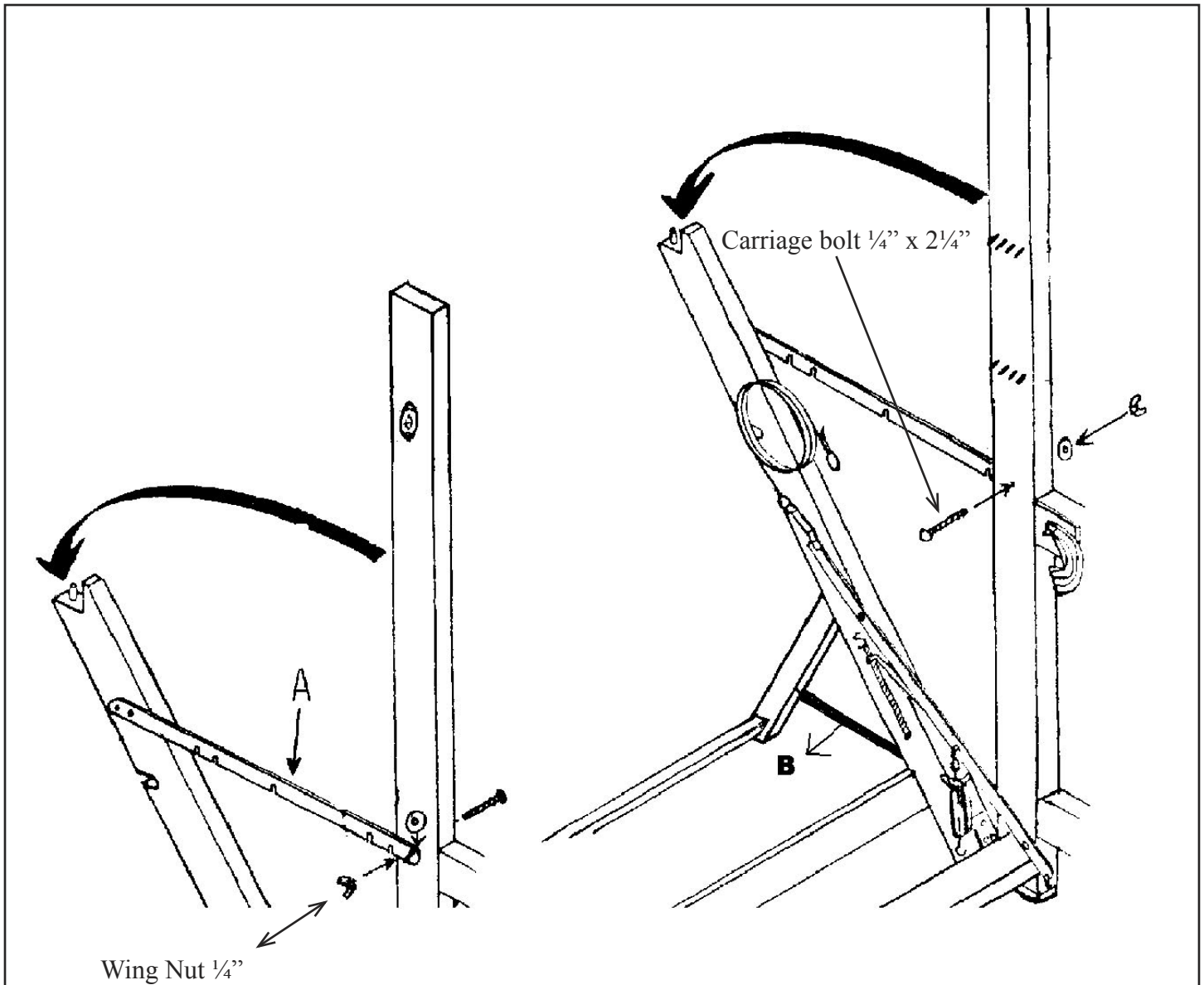

Fig. 4

Place the loom right side up.  
 Unfold the back section of the loom.

Insert a  $\frac{1}{4}$ " x  $2\frac{1}{4}$ " carriage bolt into the holes of the uprights. The nylon washer is already installed in the upright. Affix the  $\frac{1}{4}$ " wing nuts.

Lock it in place with metal hooks A at the last notch.

Insert a  $\frac{1}{4}$ " X  $2\frac{1}{4}$ " carriage bolt into the holes of the stabilizing posts (inside to outside). The nylon washer is already installed in the posts. Affix the  $\frac{1}{4}$ " wing nuts.

Unfold the back section of the loom and lock it in place with metal hooks B.

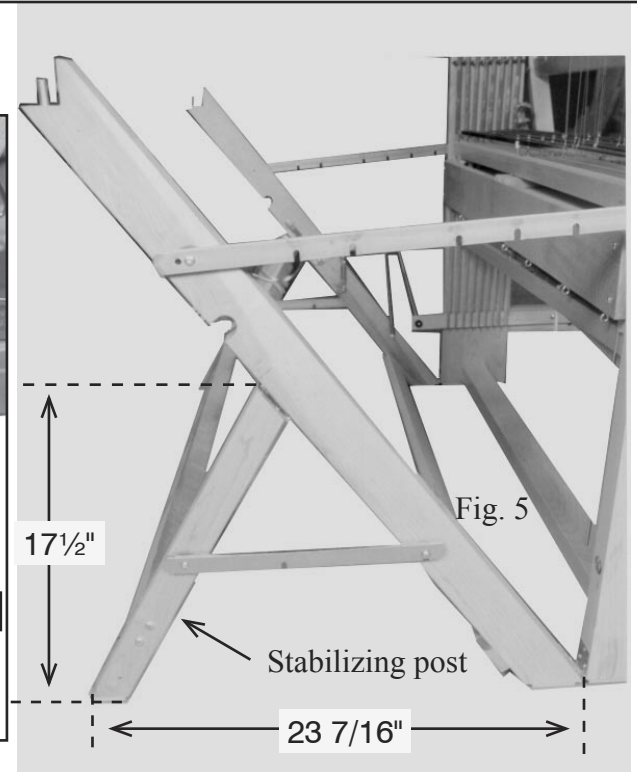
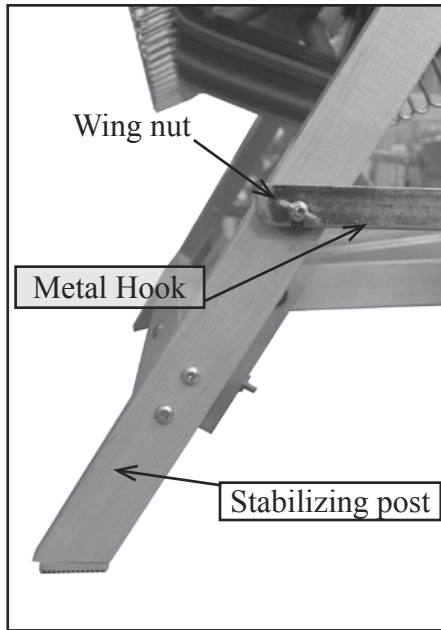

### TREADLE SET ASSEMBLY

Assemble the treadle set (in or out of the loom).

- 1 treadle rod  $28\frac{3}{4}$ " with one push nut already on one side.
- 10 treadles
- 8 wood spacers  $1\frac{1}{2}$ "
- 3 treadle blocks
- 4 x  $9/16$ " washers
- 1 push nut to be installed after the set is on the loom.

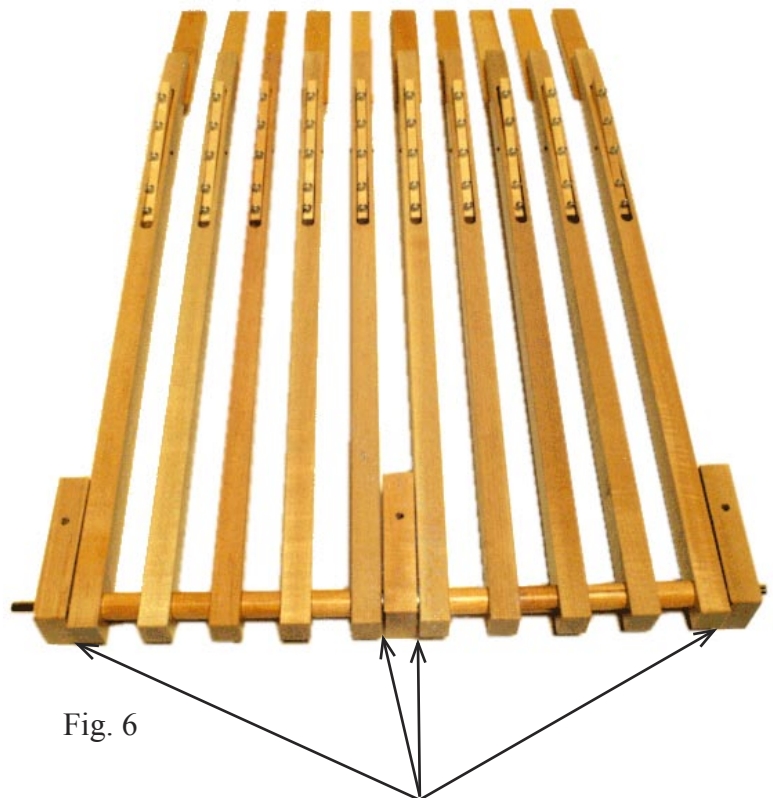

4 washers  $9/16$ " are installed between treadle and treadle block.

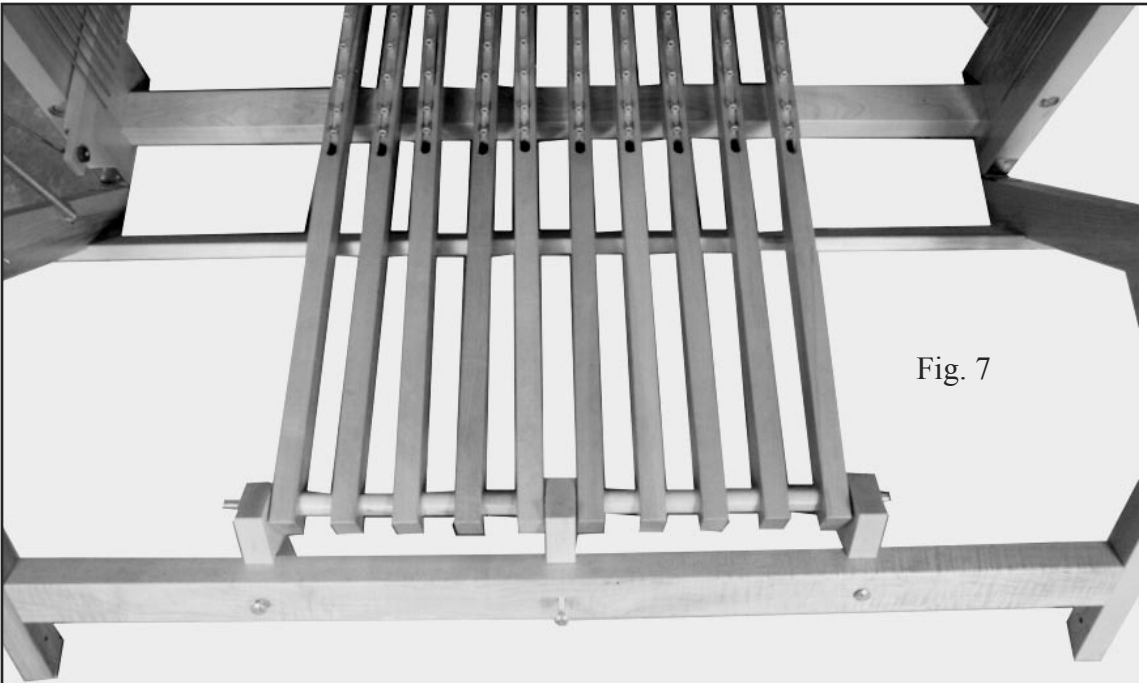

Fig. 7

Affix the treadle set to the treadle cross-member using: 3 carriage bolts 5/16" x 4"  
(from outside to inside of the loom)  
3 washers 5/16" (inside of the loom)  
3 Square nuts 5/16"



Fig. 8

### **TREADLE SEPARATOR**

Put the treadle separator in top of the loom middle cross-member and secure using 2X 1½" round-headed screws #8.

**ATTENTION: Application of soap to the screws will make their insertion easier.**

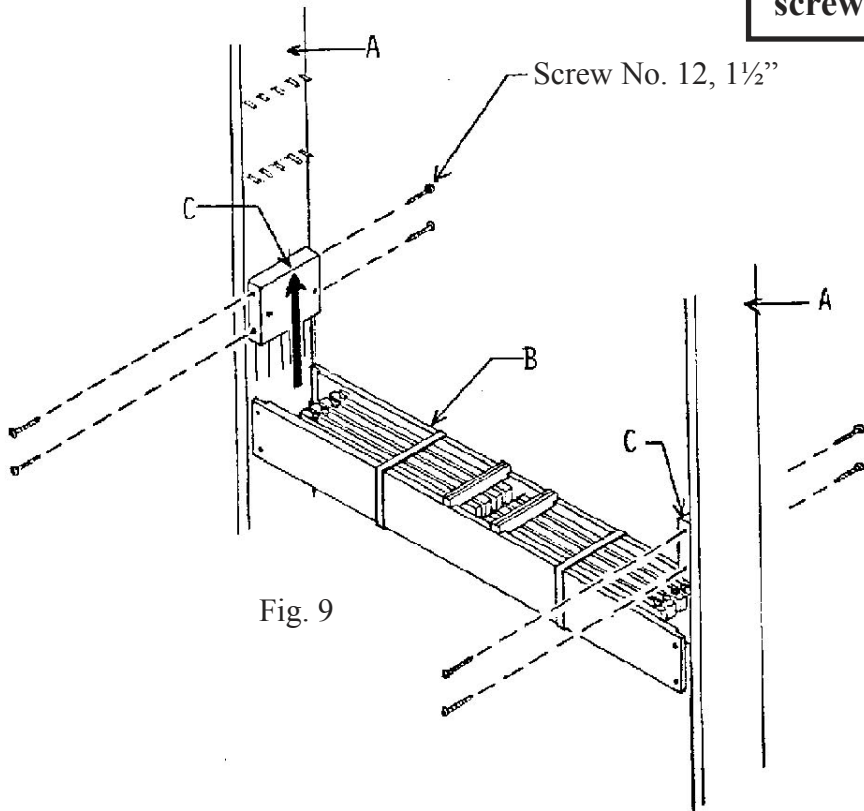

Fig. 9

Slide jack box B along the middle posts A, from bottom to top, and affix it to blocks C using eight 1 1/2" (40 mm) round-headed screws no. 12.

NOTE: The board which has 10 screws across it is the one that goes in the front, bottom of the loom.

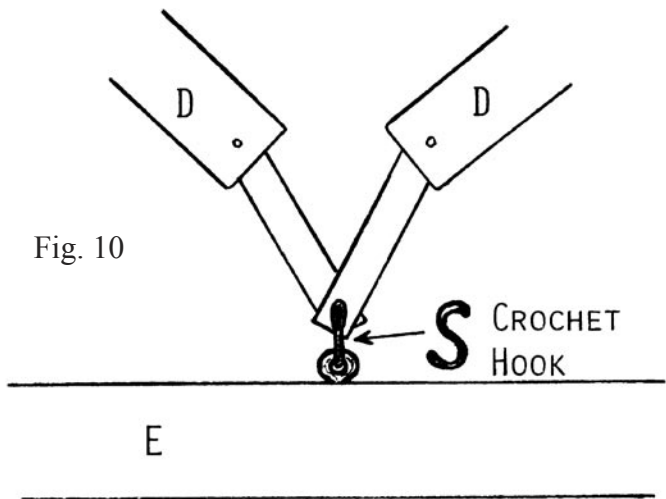

Fig. 10

Remove the saran wrap tape and put the "S" hook of the jacks D inside the eyelet of the lam E.

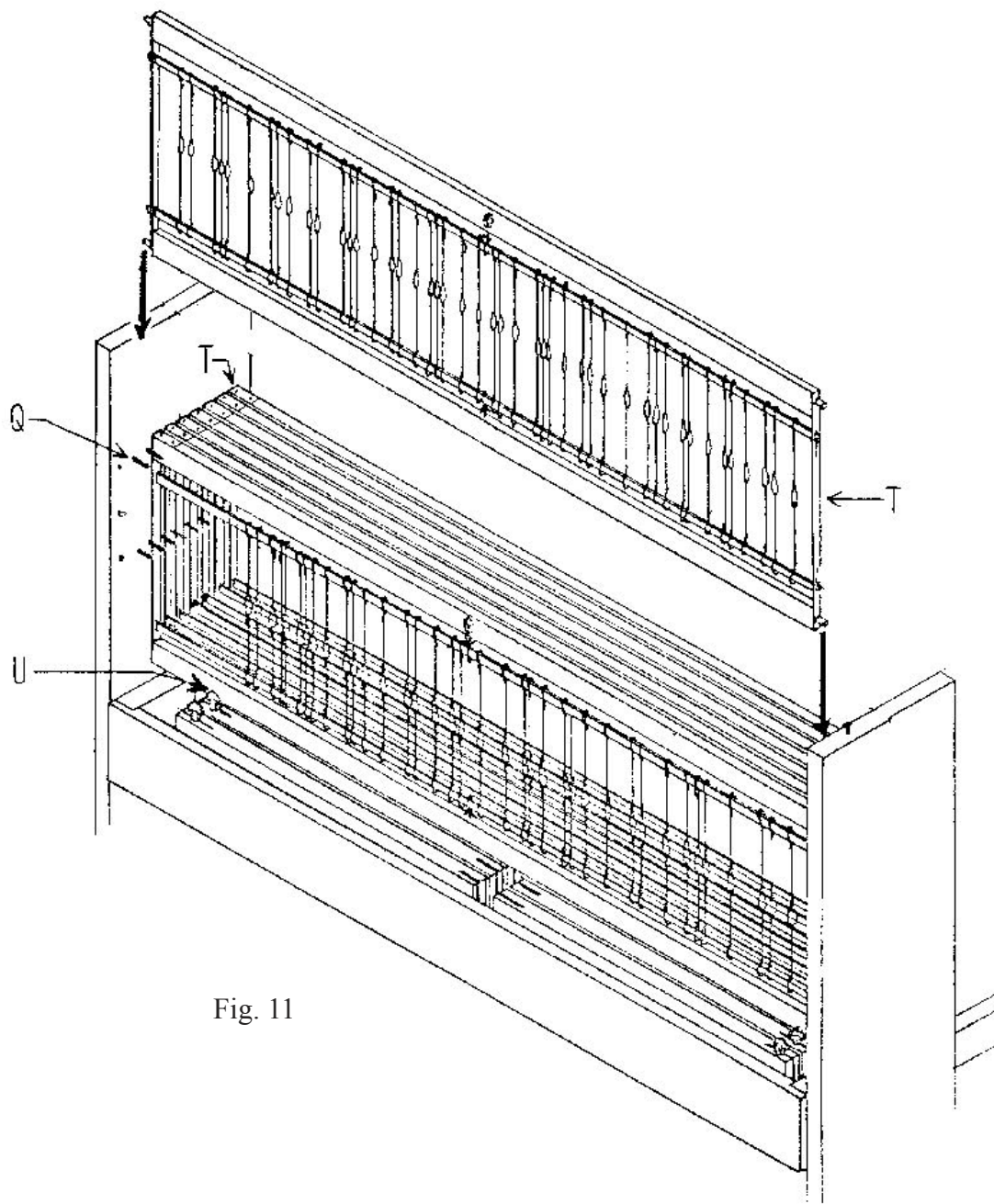

Fig. 11

Install the heddles in the shaft frames. (see "WARP AND WEAVE" on page 10)

Slide shaft frames T between dividers Q.

The shaft frames must rest on the plastic supports U of the jacks (harness guides).

The Leclerc Logo must be on top, facing the front of the loom.

NOTE: Some shafts may be tight between the castle frame until the castle top is attached.

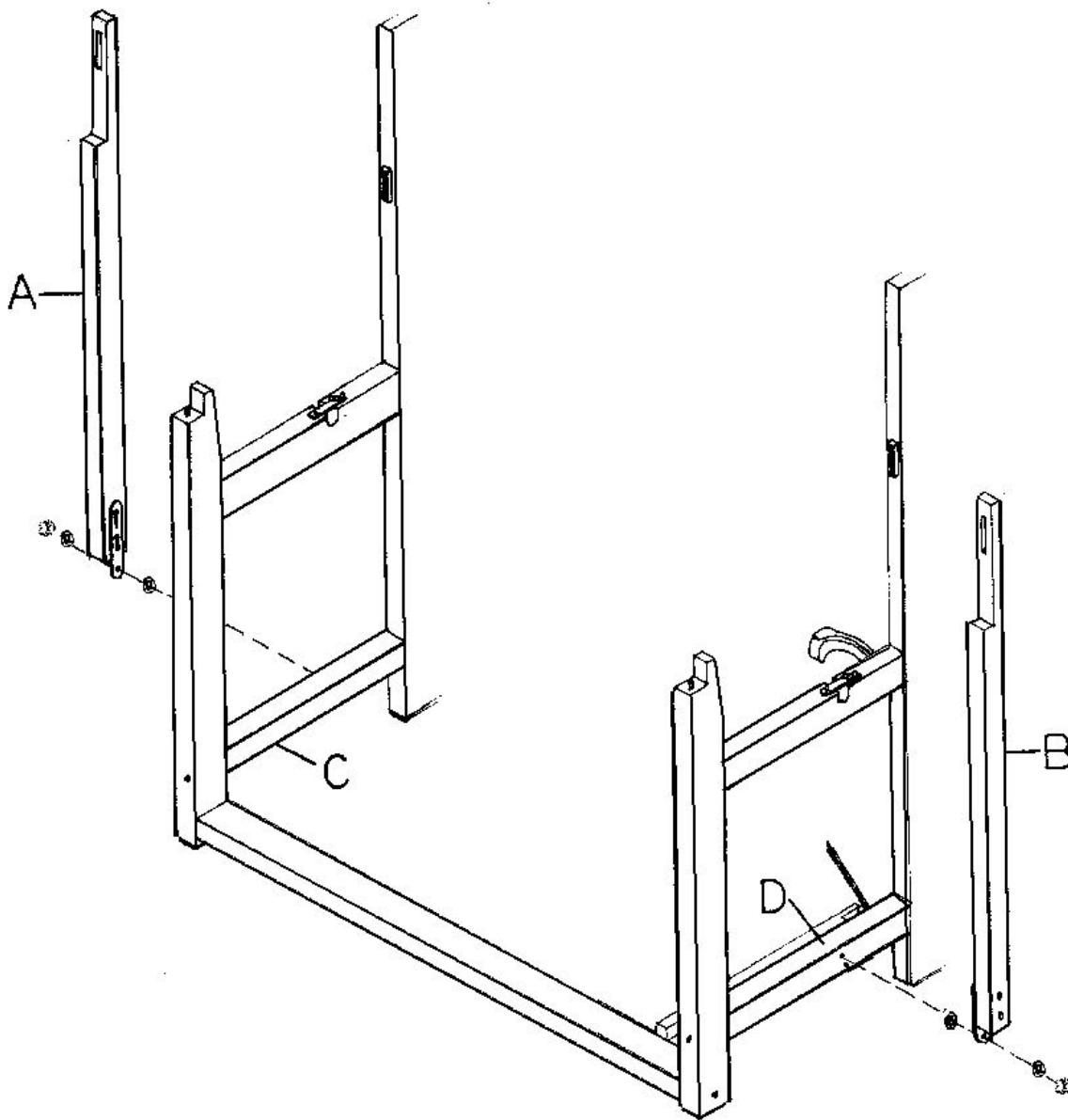

**NOTE:**

- 1) You will have to remove the brake treadle in order to be able to insert the right side carriage bolt.**
- 2) Hammer the carriage bolt inside the hole so it will lock while you will screw the auto lock nuts.**

Using 5/16" x 2¼" (8 mm x 55 mm) carriage bolts, affix swords A and B to the lower front cross-members C and D. Insert the bolt from the inside into the **upper hole** (jack type loom). Place a 5/16" (8 mm) steel washer between the cross-member and the sword and another on the outside. Then add a 5/16" (8 mm) nylon auto lock nut.

The grooves on top of the swords must be in front.



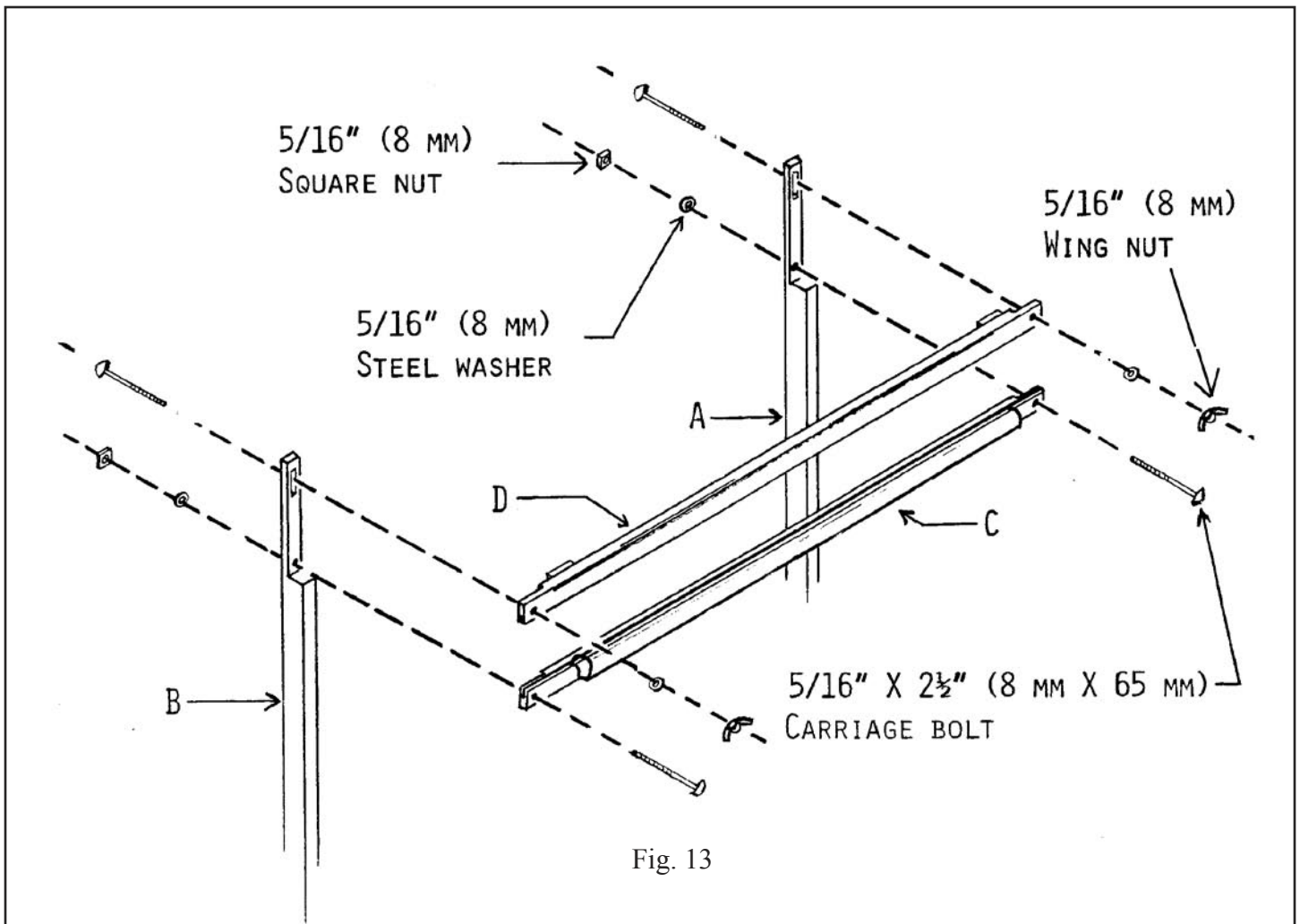

Fig. 13

Using two (2) 5/16" x 2½" (8 mm x 65 mm) carriage bolts, two 5/16" (8 mm) steel washers, and two square nuts, affix batten sley C to the lower holes of swords A and B. (Fig. 13)

NOTE: The batten sley does not have polyvinyl bumpers but it has a shuttle race.

Using two 5/16" X 2½" (8 mm X 65 mm) carriage bolts, two 5/16" (8 mm) steel washers, and two wing nuts, affix batten handtree D to swords A and B. (Fig. 14)

NOTE: The batten handtree has polyvinyl bumpers.

The slots of the batten sley and handtree must face each other.

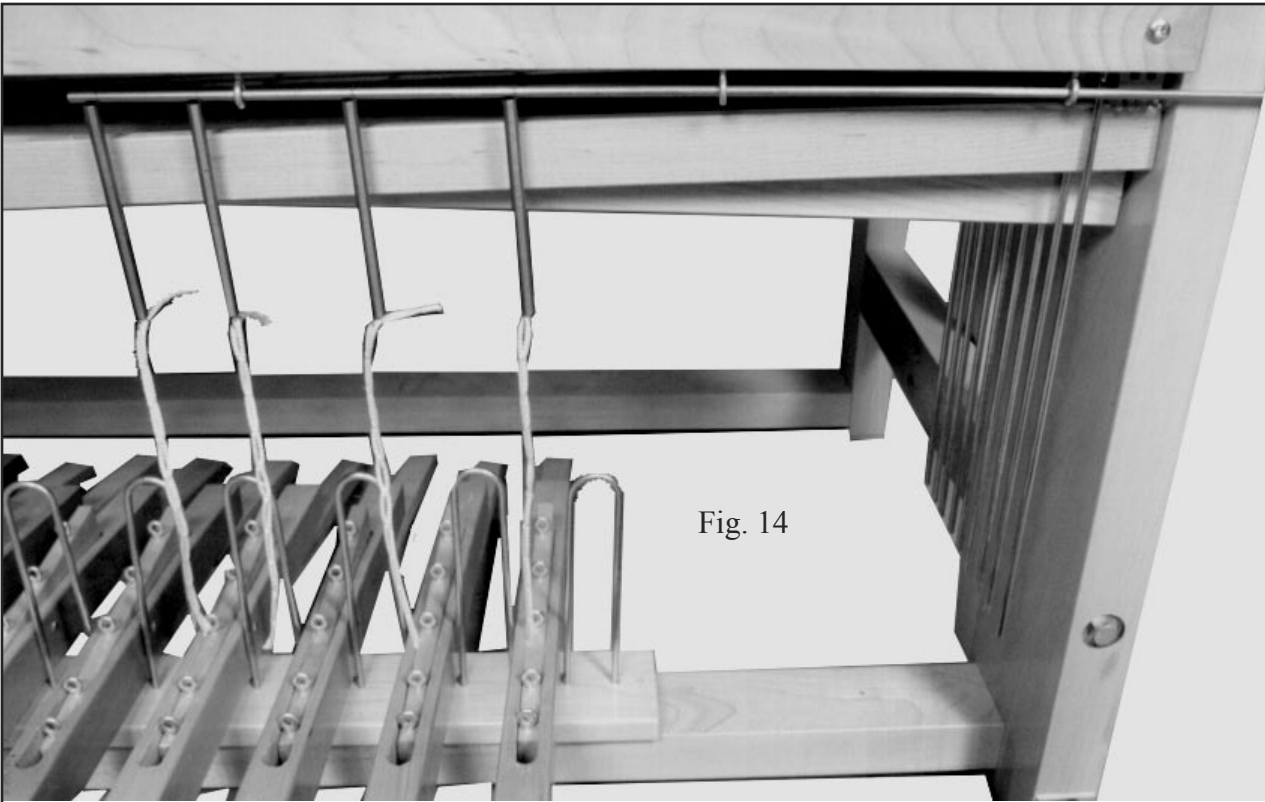

Fig. 14

### TREADLE SPRINGS

Insert the Spring Rod and Springs in the Screw Eyes below the Jack Back Board aligning one spring above each treadle.

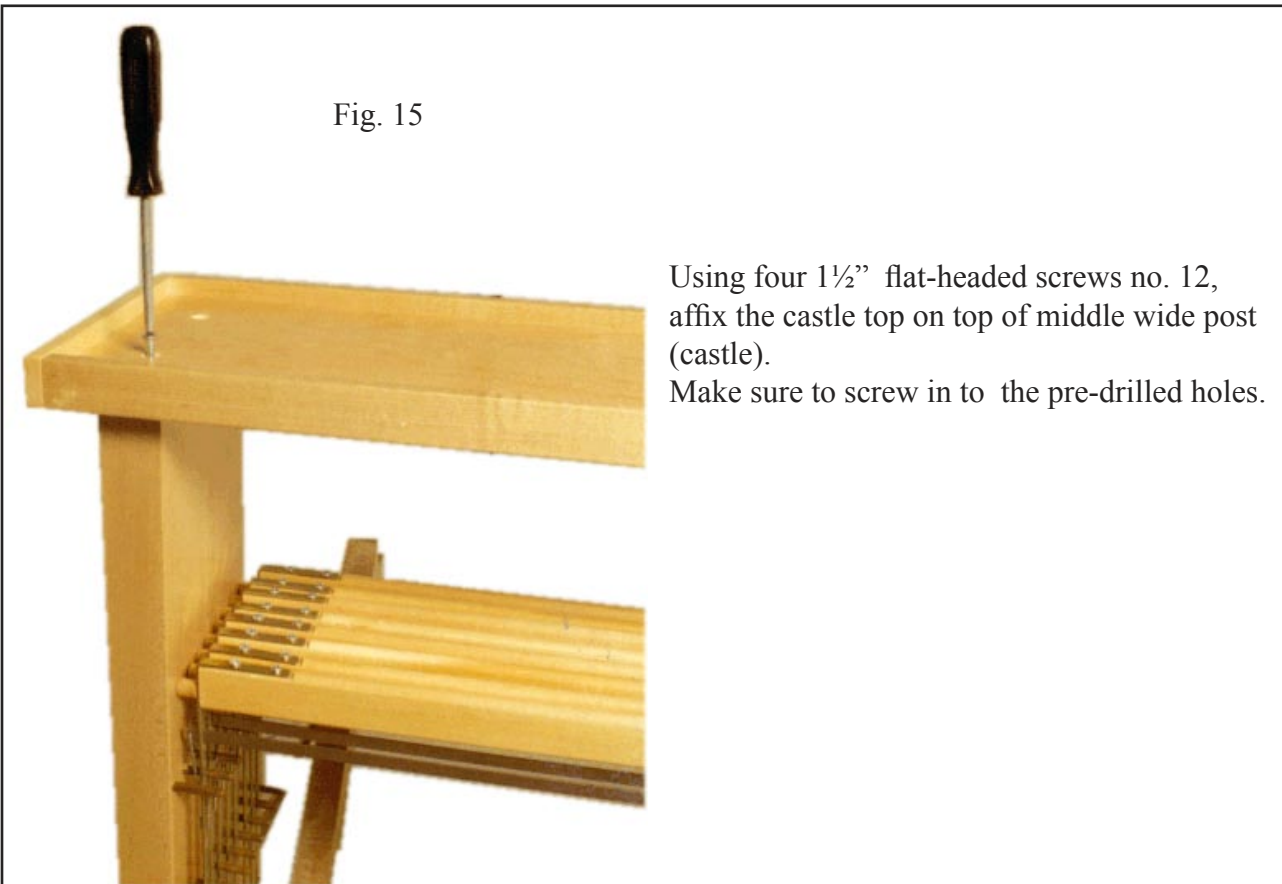

Fig. 15

Using four 1½" flat-headed screws no. 12, affix the castle top on top of middle wide post (castle).  
Make sure to screw in to the pre-drilled holes.

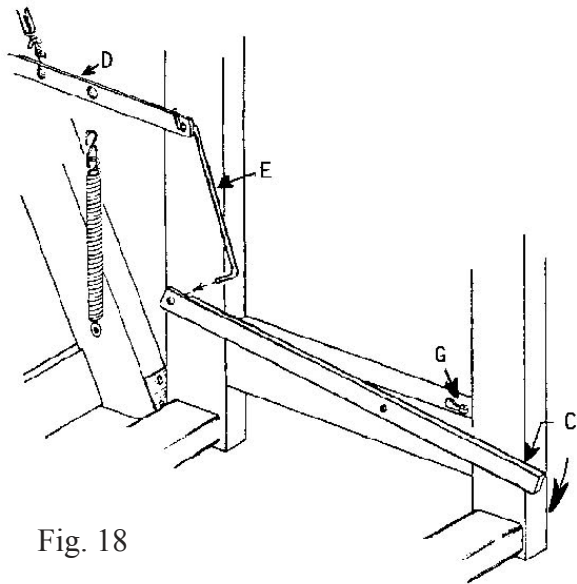

Fig. 18

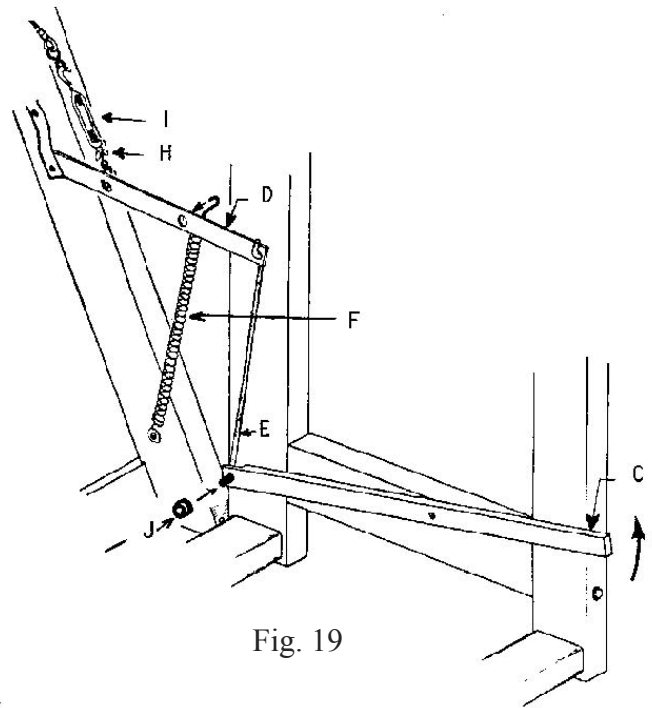

Fig. 19

Using metal rod E, join treadle C to lever D. First insert the double-cornered end of the metal rod into lever D; then insert the other end of the metal rod into treadle C while the treadle is depressed.

Raise (back part) treadle C as high as possible then hook spring F to lever D.

#### BRAKE ADJUSTMENT:

Release the brake by depressing treadle C and locking it down with the catch G. The warp beam should turn freely but the circular brake wire should not be too slack. If the tension is too great, unscrew the wing nut H slightly and then loosen the turnbuckle I. If the tension is too slack, tighten the turnbuckle I slightly and then the wing nut H.

Insert the black rubber ring J to the lower end of the rod E, to prevent the rod from slipping out.

#### **BEAMING**

*Release the brake by depressing the brake treadle (C) and locking it down with catch (G).*

#### **WEAVING**

*To advance the warp, depress brake treadle (C) and turn cloth beam (H) at the same time. Then, release brake treadle (C) (engaging the brake) and advance the cloth beam until the desired tension is achieved.*

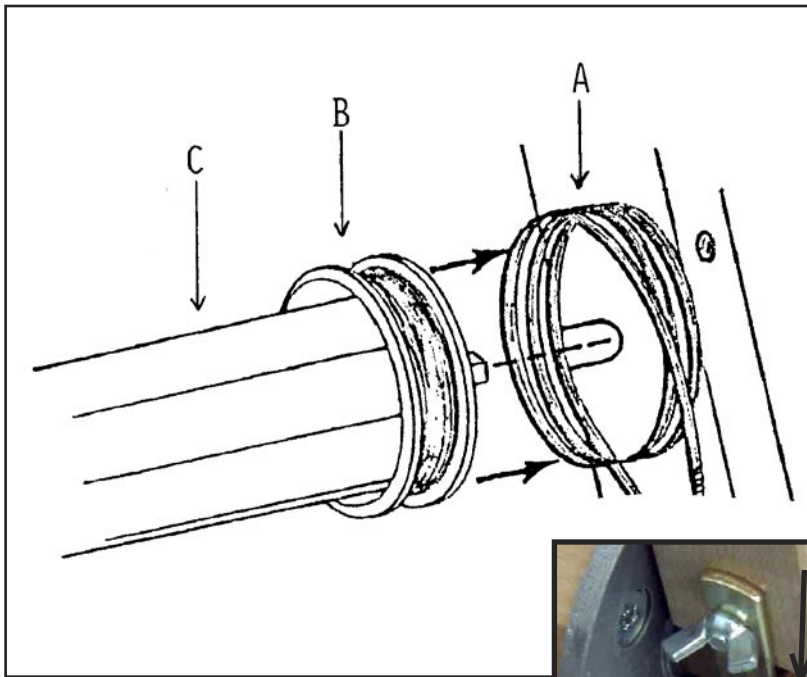

## WARP BEAM INSTALLATION

Hold the circular wire brake shoe A slightly to the rear of the loom, **but do not unroll it.**

Insert the brake drum B into the wire brake shoe A. Then, install the ends of the warp beam C into the grooves of the back posts.



In order to improve the rotation of the warp beam, special bushings are supplied. Make sure to leave them in place when installing the warp beam on the loom.

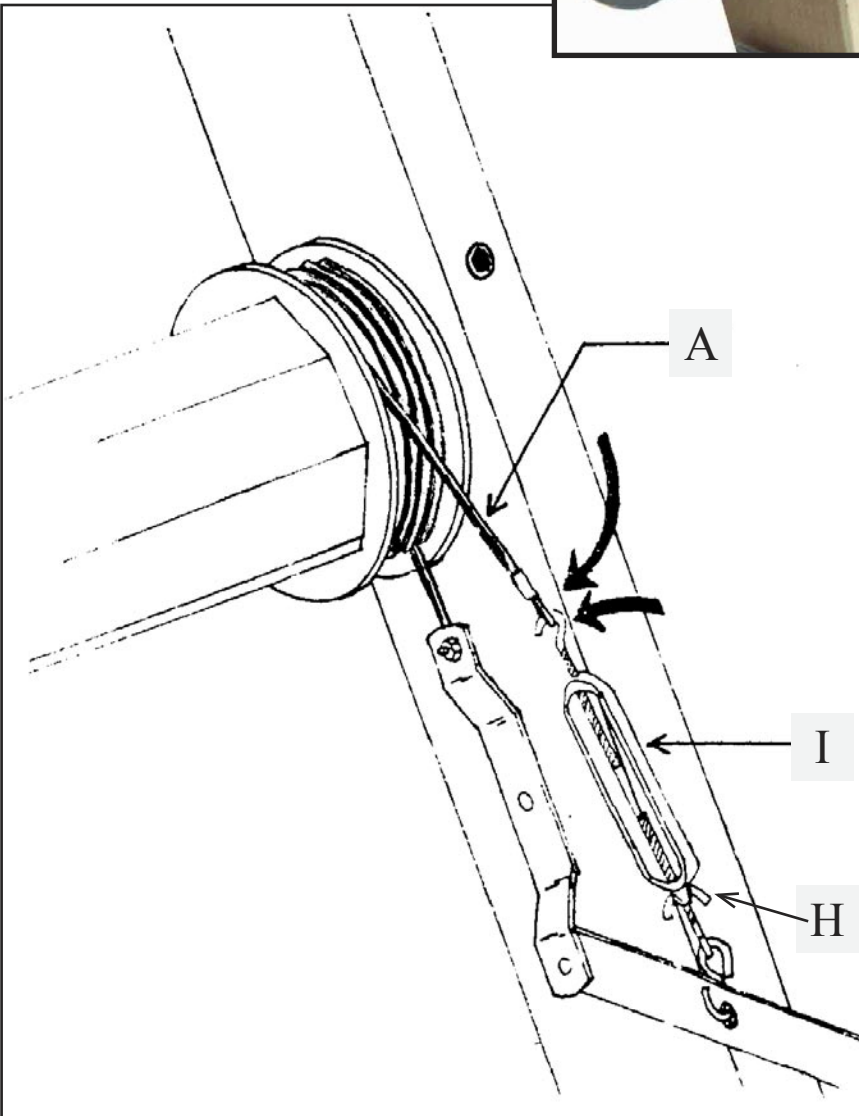

Hook turnbuckle I to flat wire circle A.

### BRAKE ADJUSTMENT:

Release the brake by depressing the brake treadle and locking it down with the catch G.

The warp beam should turn freely but the brake circle should not be too slack. If the tension is too great, unscrew the wing nut H slightly and then loosen the turnbuckle I. If the tension is too slack or the beam is turning counterclockwise (while standing on the brake side of the loom), tighten the turnbuckle I slightly and then the wing nut H.

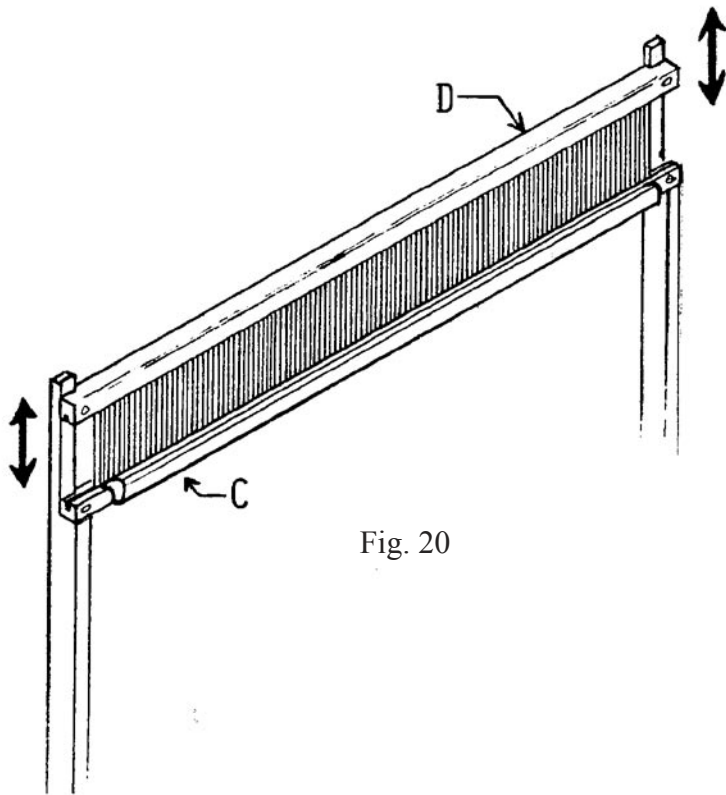
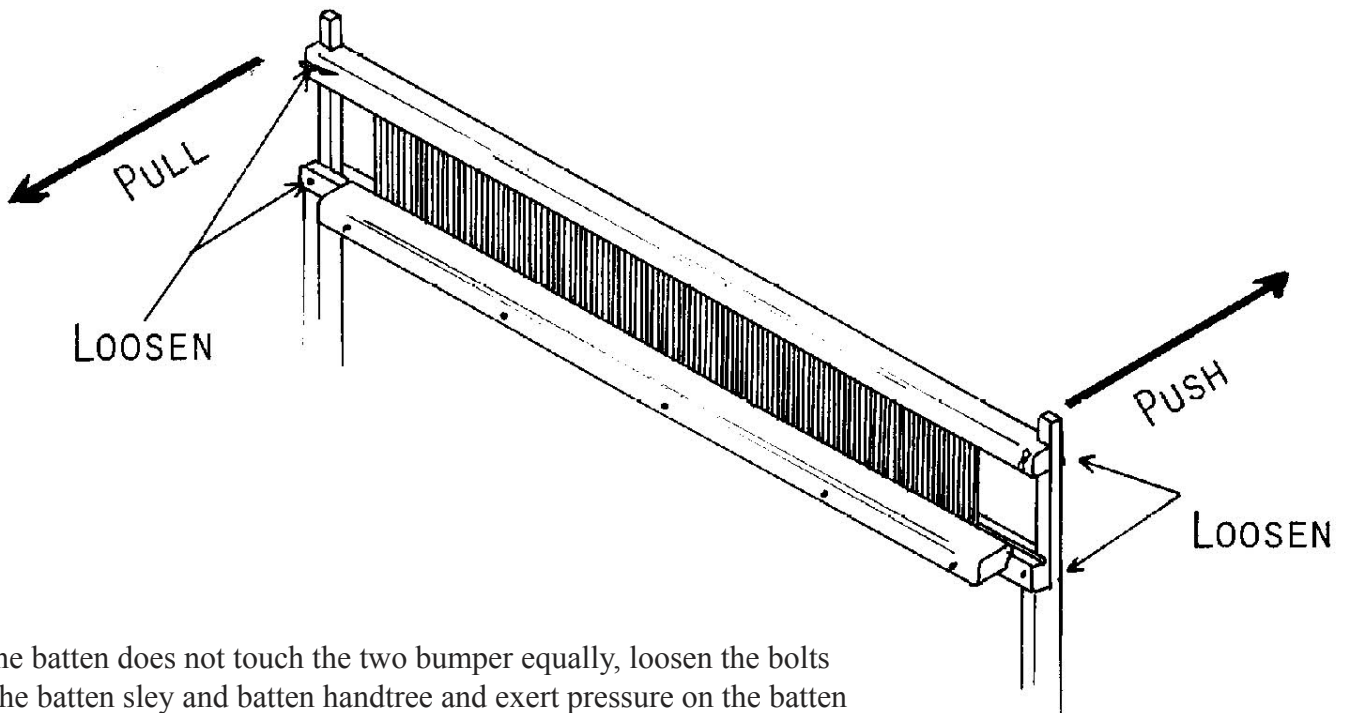
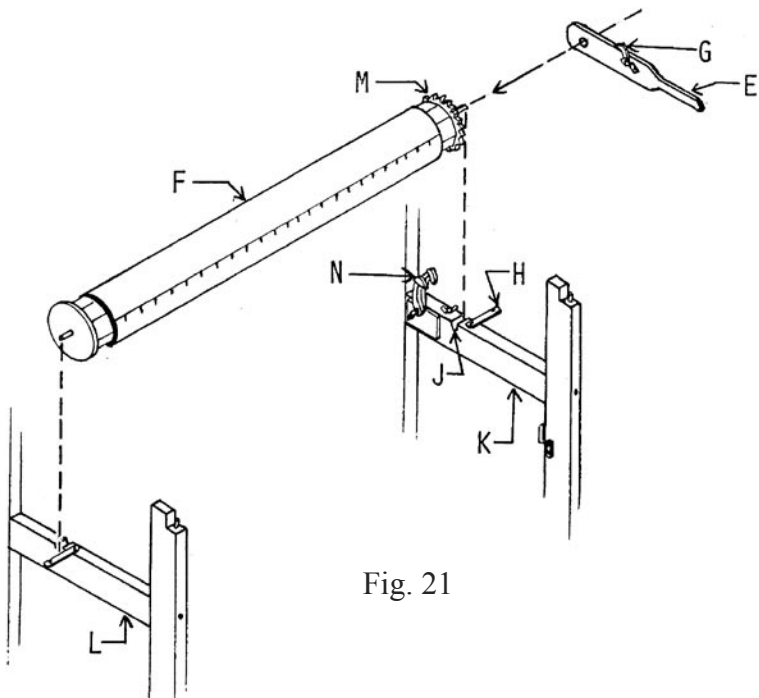

Fig. 20

Place the reed between batten sley C and handtree D. (Fig. 20)  
 When the wing nuts are loose, the batten handtree can slide vertically in the sword slots. The reed must then be secured between the batten sley and handtree by tightening the wing nuts. If the batten does not touch the two bumpers equally, loosen the bolts of the batten sley and handtree and exert pressure on the batten centering it in its proper place. Tighten the bolts again.



If the batten does not touch the two bumper equally, loosen the bolts of the batten sley and batten handtree and exert pressure on the batten centering it in its proper place. Tighten the bolts again while keeping pressure in the batten.



Install take-up motion handle E on the axle end of cloth beam F (on the same side as the ratchet gear). Ratchet pawl G of the take-up motion handle must be lifted up. (Fig. 21)

Open beam latches H and place the beam ends in the slots J of the upper side cross-members K and L. (Fig. 21)

Note: Ratchet gear M must be on the right-hand side and ratchet pawls N must be lifted up.

Fig. 21

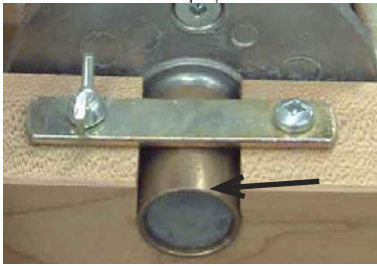

In order to improve the rotation of the cloth beam, special bushings are supplied. Make sure to leave them in place when installing the cloth beam on the loom.

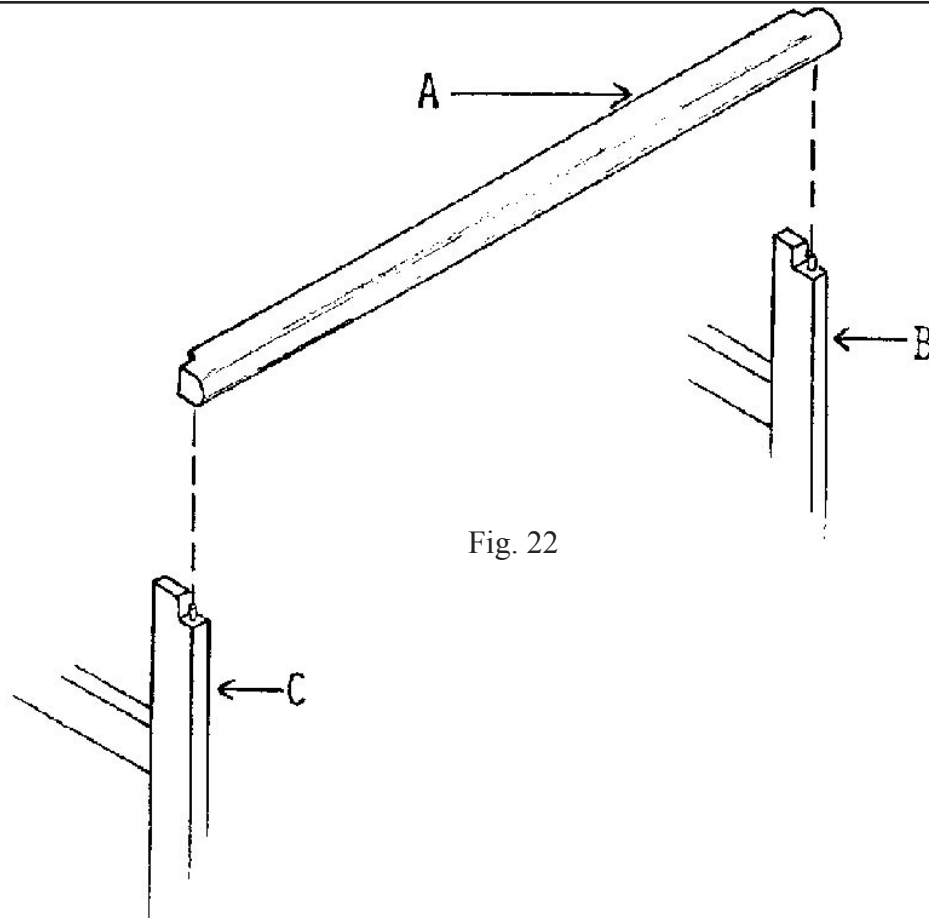

Affix one of the breast beams A on the top of the front posts B and C. (Fig. 22)

Affix the other breast beam on top of the back posts.

NOTE: To avoid splitting the front posts, slightly insert the breast beam onto the metal pin. Be sure that it is in the right position before inserting it completely.

Fig. 22

## FOLDING LOOM AND BEAMING:

Release the brake by depressing treadle C and by locking it down with catch G. Release the 4 metal hooks and fold the back of the loom.

## WEAVING:

To advance the warp, depress brake treadle C and turn cloth beam H at the same time. Then release brake treadle C and advance the cloth beam until the next notch in the ratchet gear is reached.

If this is too much tension, gently depress the brake treadle until the desired tension is obtained. (Fig. 23)

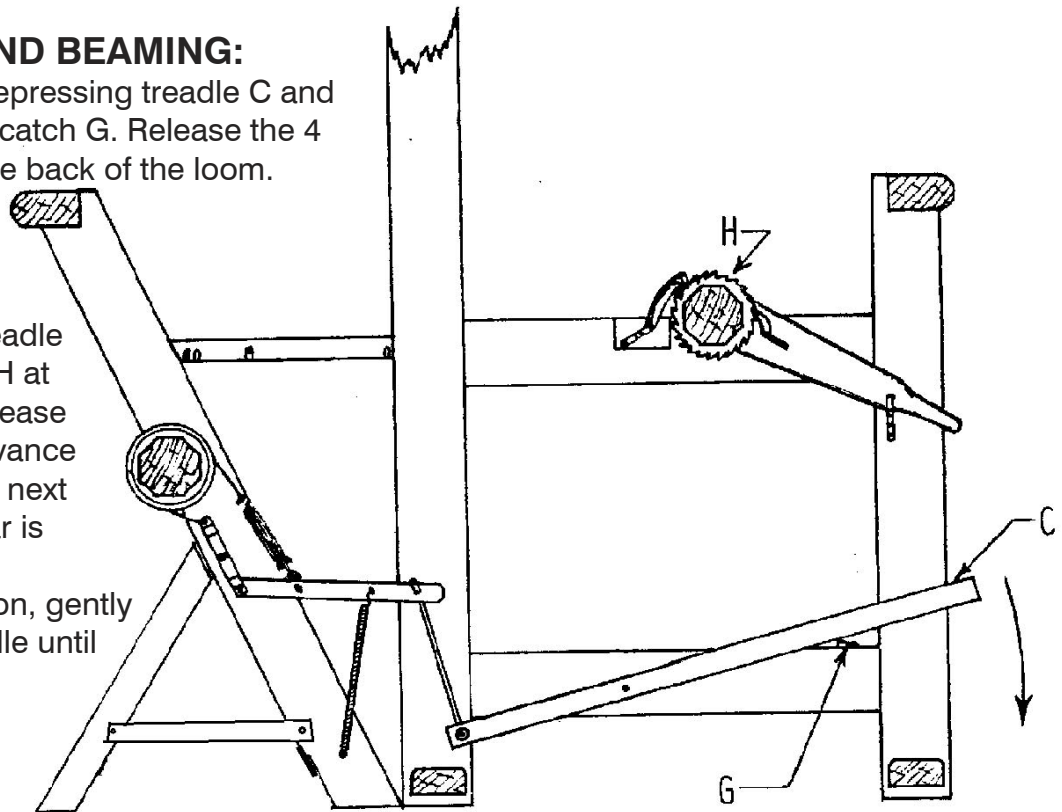

## Note while winding a warp with a Leclerc Friction Brake

To maintain proper adjustment and operation of your Friction Brake, it is recommended that the Brake be disengaged while winding the Warp.

On those looms designed with a Treadle or Lever Lock, the Brake should be locked open when winding.

## MORE INFORMATION:

See "WARP AND WEAVE"

Install the Warp beam advance control system. This system will eliminate excessive warp yarn advance when releasing the brake system at cloth take-up. This friction system is adjustable and have to be released when winding the warp on. Just screw the handle in to increase the friction or unscrew it to release. Affix it to the back left side of the loom using 2 round head screws no 12 - 1" to the pre-drill holes.

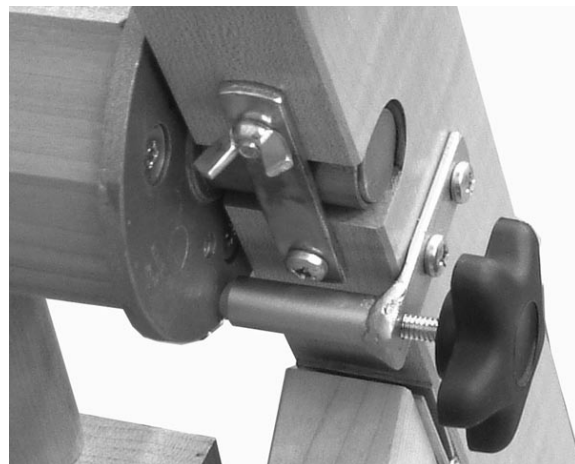

### FIRST TREADLE TIE-UP

Select any treadle and tie the Lams to the Treadles using the 7" cords supplied with the loom. Take the threading hook to help pass the cord through each hole of the lam.

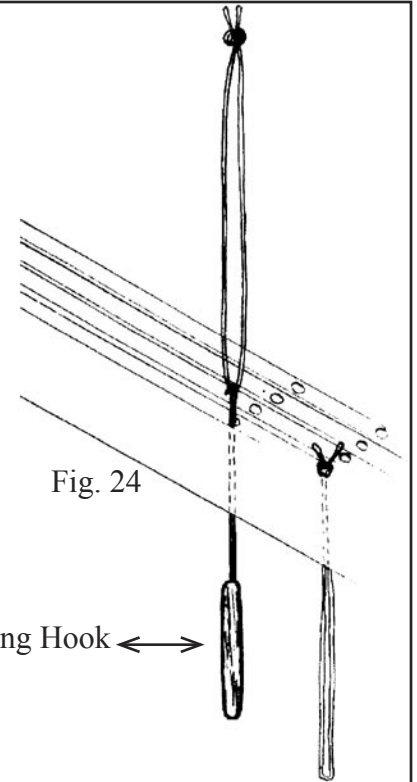

### TREADLE HOOK AND ROCKER LOOP CORD

Slide the Treadle Hook through the Screw Eyes and Cord Loops. Before the last Screw Eye, insert the Hook through the Treadle Spring and secure. In the Treadle rest position (up) there should be no or very little tension on the Spring. However, slack on those cords is not desirable. When all treadles are tied up, they should be at the same height.

Install the Treadle Rocker Loop Cord on the Anchors (Screw Heads) using the marked points at the Anchor. (see diagram)

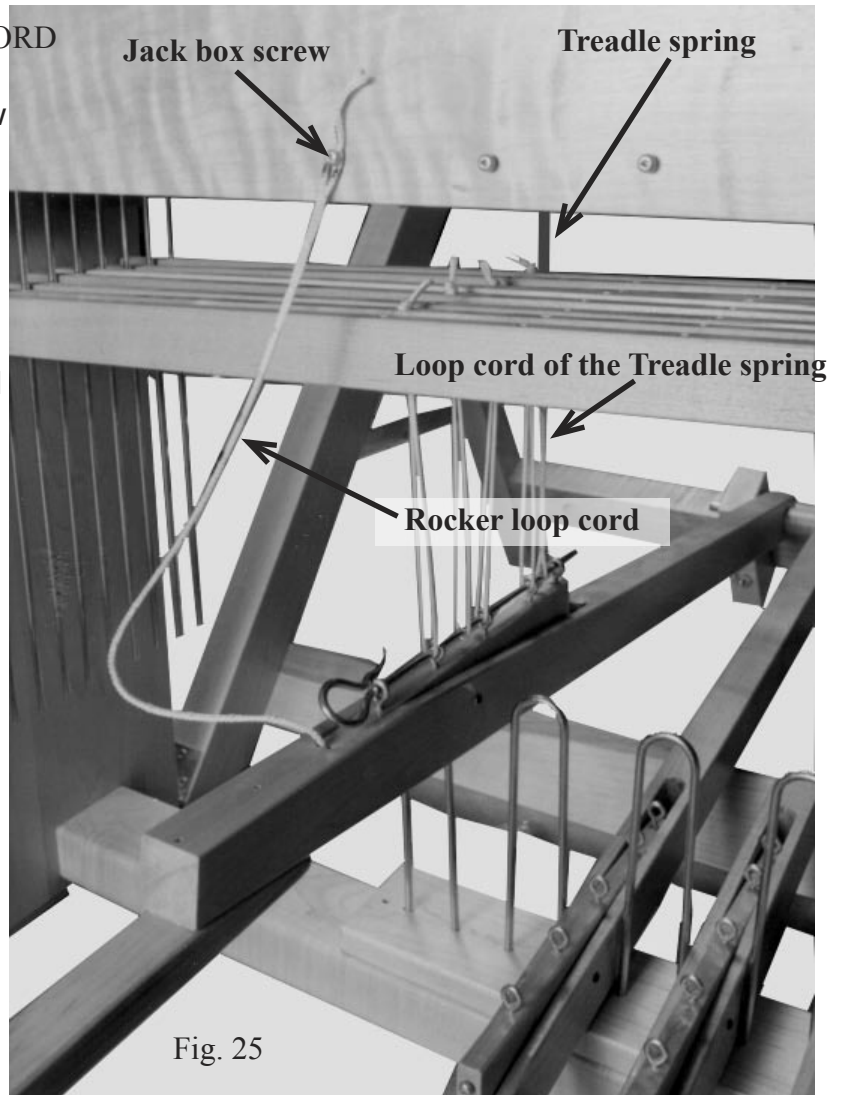



**FIRST SHED**

When you depress the Treadle, the Rocker Loop Cord raises the front of the Rocker setting the Shafts at the correct Level.

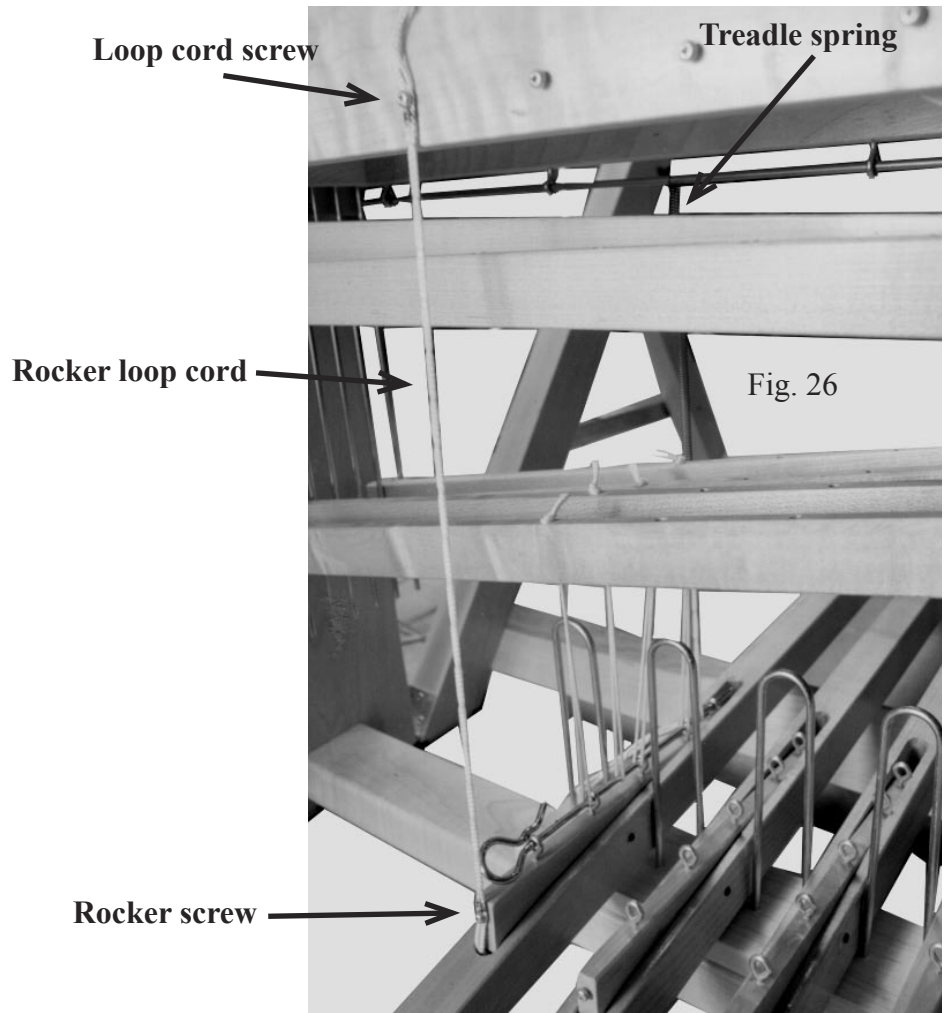

**VIEW FROM THE BACK OF THE LOOM SHOWING THE TREADLE AT REST POSITION AND DEPRESSED.**

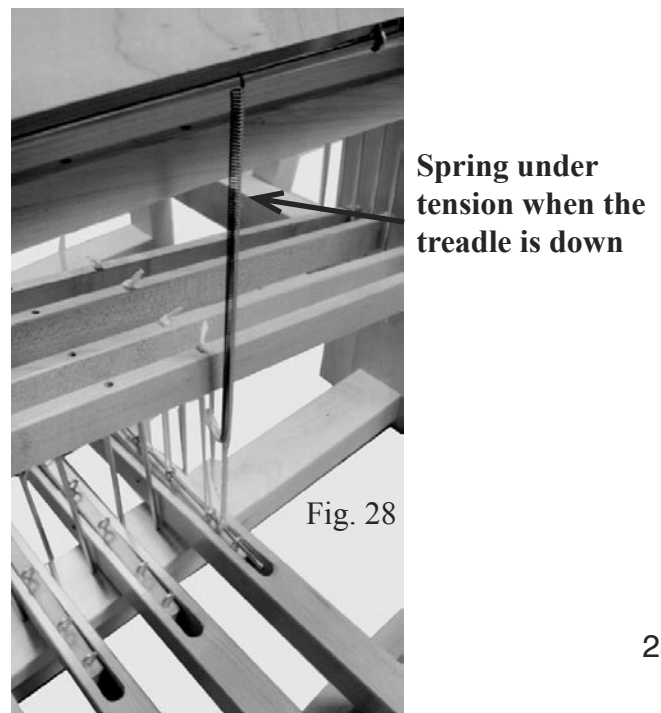
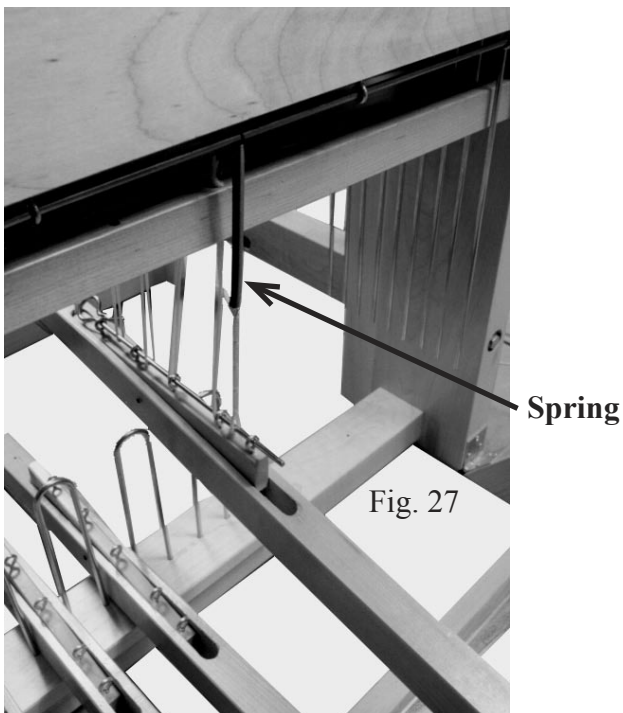

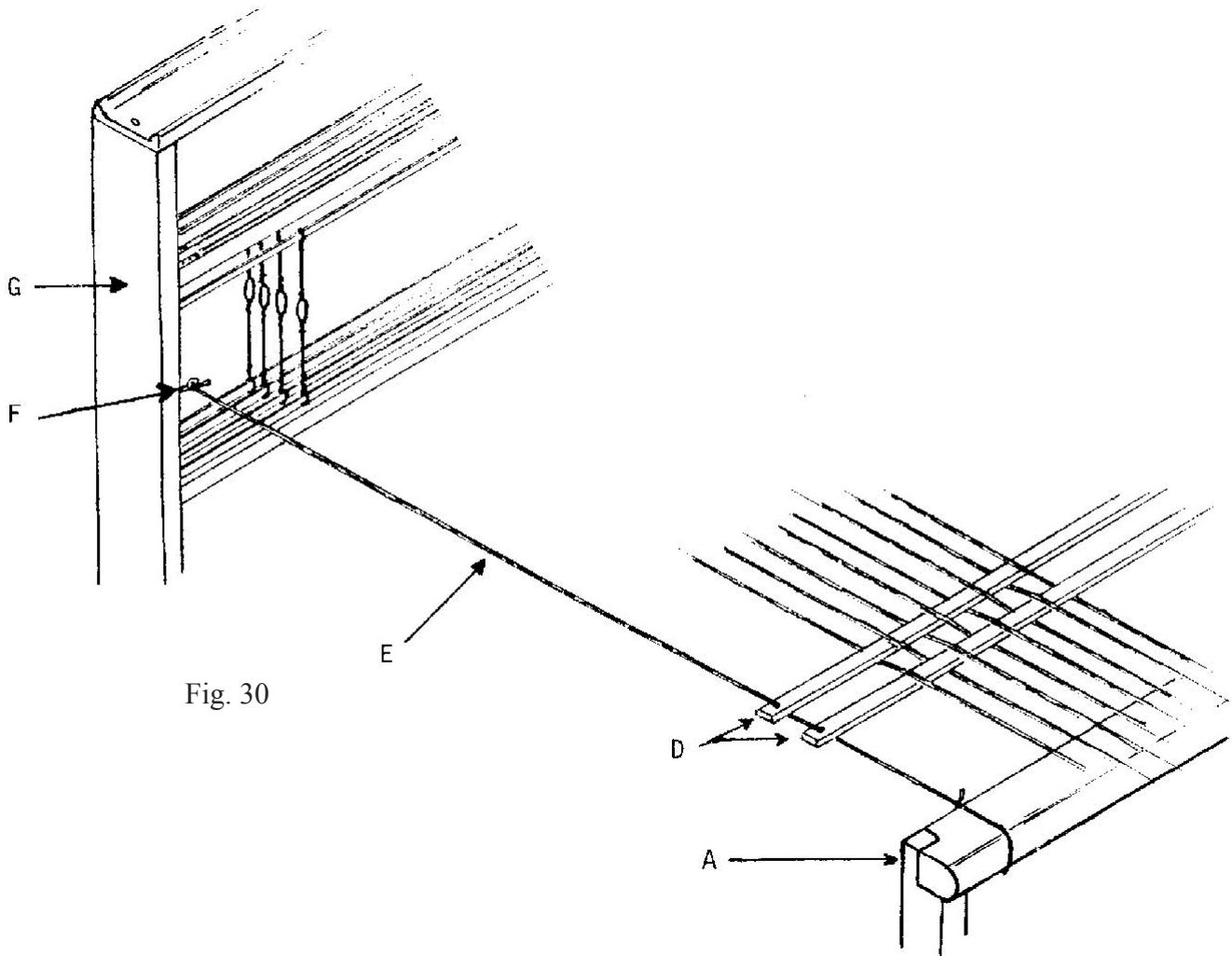

Fig. 30

Affix screw eyes F to the holes inside middle posts G.

Pass a string C through the holes at each side of the lease sticks D and tie them to the screw eyes and to the thread beam A. The lease sticks will be held at the right height and distance for easy threading. (Fig. 30)

If the loom is equipped with a sectional warp beam, affix the rake-like pieces (following the instructions supplied with the sectional warp beam) and do the following instructions on the cloth beam only.

If the loom is not equipped with a sectional warp beam, affix the apron to the warp beam with tacks and do the following procedures on the warp and cloth beams.

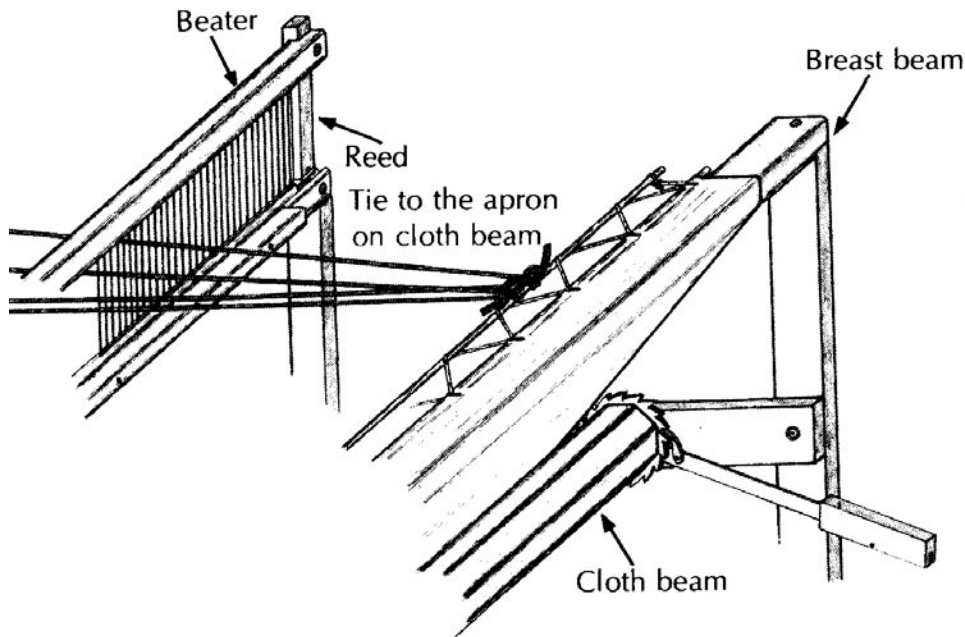

Insert a warp rod into the apron border.

For 27", 36" and 45" loom  
(70cm, 90cm and 115cm)

For 60" loom  
(150cm)

Cut the 5 yard (4.5m) cord in half.  
Use one half of the cord to lace the apron warp rod to a second warp rod. This second warp rod will be used to attach warp threads.

Use a 5 yard (4.5m) cord to lace the apron warp rod to a second warp rod. This second warp rod will be used to attach warp threads.

**We at Leclerc encourage Weaver feedback on  
this and all our products. Please  
send your comments to Leclerc Loom Co.  
[info@leclerclooms.com](mailto:info@leclerclooms.com)**

**HAPPY WEAVING**

## ADJUSTING THE SHED

The key to a wide clean shed is the proper adjustment of the Rocker Loop Cord. Once you have completed the hookup of the Cords and Springs, start at one end of the Treadle Set and depress each Treadle one at a time noting the position of the bottom Shed. Adjust each Shed by shortening or lengthening the Loop Cord. When properly adjusted, the bottom Shed of each Treadle should just kiss the Race Plate and the top Shed should be uniform across the width of the Loom. (see diagrams for examples)

Picture #32 shows an uneven Shed caused by Rocker Loop Cords being out of adjustment.

Picture #33 shows properly adjusted Rocker Loop Cords with the bottom Shed just kissing the Race Plate and the Top Shed uniformly even across the width.

It is very important to maintain a reasonable amount of tension on the Warp when making adjustments and while weaving in order to keep a wide, clean Shed.

The design of the system provides a greater lifting force on the Shafts with considerably less leg pressure required to depress the Treadles. With a few Picks on each new project, the Weaver will find the correct Warp tension required to produce the desired PPI (Picks per Inch) in the Cloth, while maintaining a wide, clean Shed.

