

NILUS II COUNTER-BALANCED

36"	1026-0000
45"	1027-0000
60"	1028-0000



On receiving the loom, unpack and lay out the loom components. Do NOT discard any packing material until all parts are inventoried.

Check the parts received against the parts list on pages #2 to #7 of the assembly instructions. Report any discrepancies to Leclerc or your dealer immediately.

To assemble this loom, a minimum of 2 people are needed but it is recommended you use 3.

Leclerc Looms

Since 1876



1573 Savoie
C. P. 4
Plessisville, Qc.
G6L 2Y6

TEL: 819-362-7207
FAX: 819-362-2045
www.leclerclooms.com
leclerc@leclerclooms.com

PARTS LIST

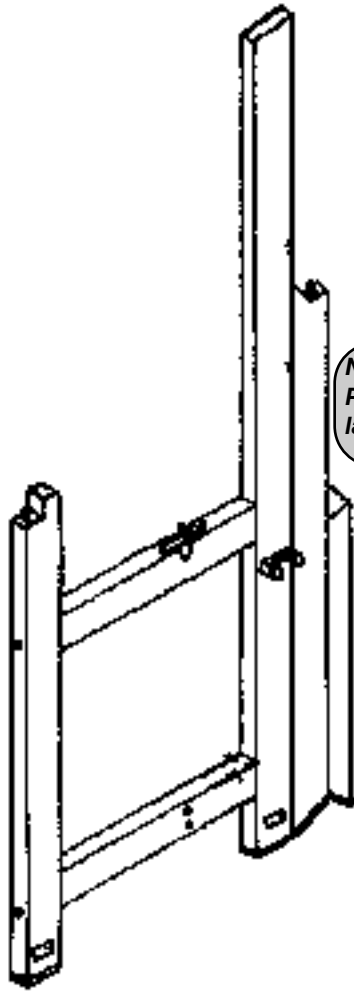

1 left-hand side of loom

*Note for Leclerc in French:
Pas de guide de cadre de
lames.*

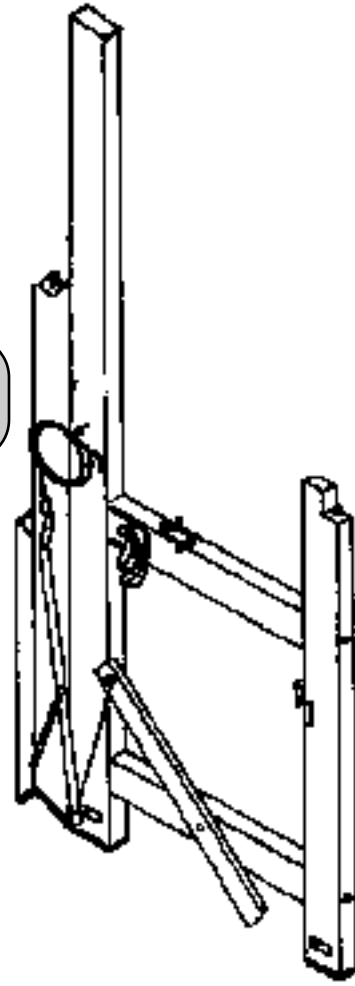

1 right-hand side of loom

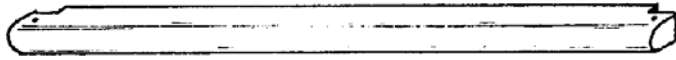

2 breast beams (43½", 52 5/8")

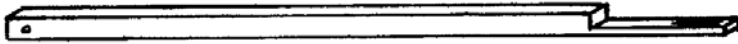

1 left sword (34 5/8")

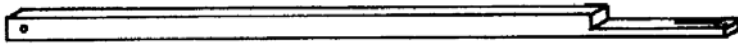

1 right sword (34 5/8")

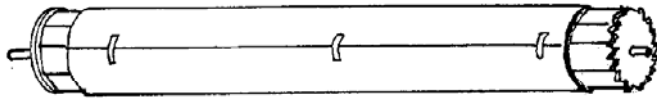

1 cloth (front) beam
(38½" , 47 4/8")

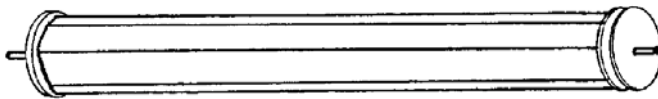

1 warp (back) beam
(38½" , 47 5/8")

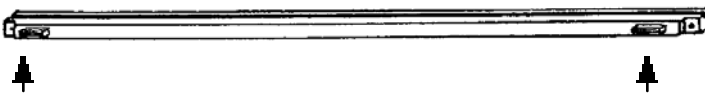

1 batten handtree with bumpers
(46¾", 55¾")



1 batten sley with **shuttle race**
(46¾", 55¾")

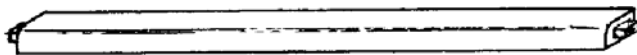

1 lower-middle cross-member
(40 1/8", 49")

15 7/8" CC

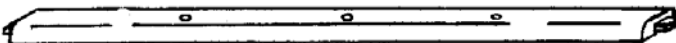

1 treadle set cross-member
(40 1/8", 49")

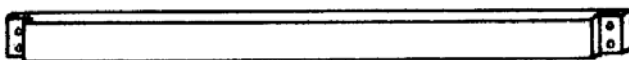

1 lower cross-member
connecting back posts
(34½", 52 5/8")

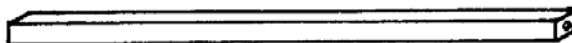

1 cross-member connecting the
stabilizing posts



1 apron



1 cloth take-up motion handle



1 shed regulator roller

Note for Leclerc in French: Ne pas oublier les petits trous sur la poulie , sur les rouleaux de tête et octogonale.

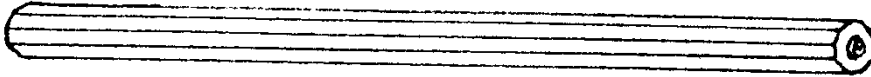

1 octagonal roller

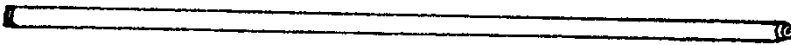

2 small rollers



1 left roller support



1 right roller support

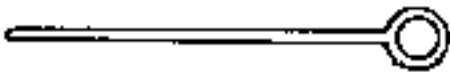

1 metal pin to lock shed reg. roller



1 open eyehook

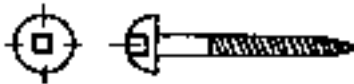

4 round-headed screws No 12, 1 1/2"



9 round-headed screws No 6, 1/2"



9 steel washers 3/16"



1 shed regulator spring

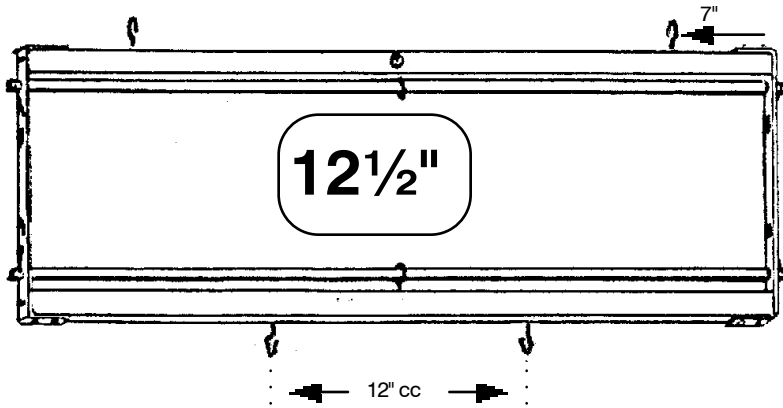

4 shaft frames

6 treadles (25 1/2")

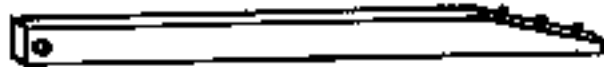

3 treadle support with



1 18" treadle set rod with
1 Push nut 7/16"



1 more treadle set
push nut 7/16"

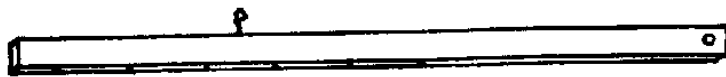

cc holes = 2 3/4"

4 lams 36" = 27 5/8"
45" = 32 1/8"
60" = 39 5/8"



1 crank

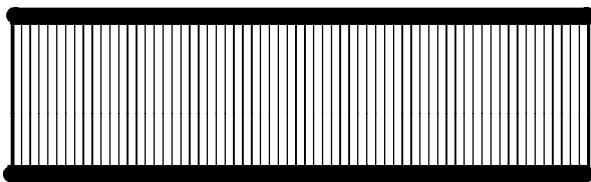

1 reed



2 lease sticks



4 rods

PARTS LIST



3 Screwdrivers (black, red and green)



1 wrench

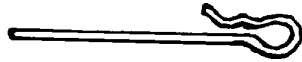

1 set of 6 treadle hooks 7" # 3500-4521



1 set of 12 treadle cords 9" #3000-7011



1 boat shuttle regular size



12 plastic bobbins 4"



1 threading hook with plastic handle



2 pk cord 5 yd each

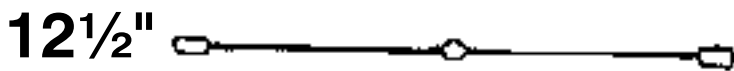

1000 heddles (36" loom)

1200 heddles (45" loom)

1500 heddles (60" loom)



2 loop cords 17"

4 loop cords 18"

4 loop cords 20"

2 loop cords 30"

1 loop cord 40"

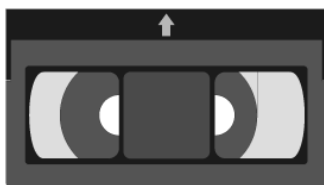

1 VHS instruction Video showing all stages of the installation.

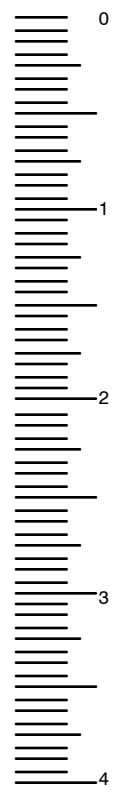

Machine bolts

4X - 3/8" x 5"
1X - 1/4" x 3"

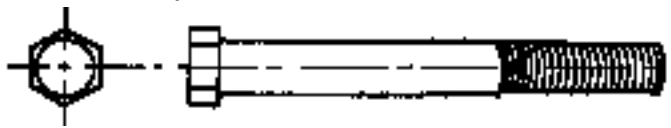

Carriage Bolts

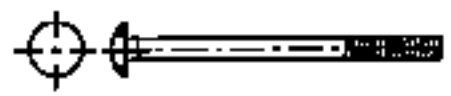

4X - 5/16" x 2 1/2" (8 mm x 65 mm)
3X - 5/16" x 4" (8mm x 10 cm)
2X - 1/4" x 2 1/4" (6mm x 56mm)
2X - 5/16" x 3 1/2" (8mm x 89mm)

HEXAGON NUTS



2X- Nylon auto lock
5/16"

Wooden spacer

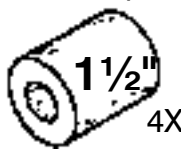

Washers

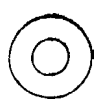

11X - 5/16"
4X - 9/16"
4X - 3/8"

Wing nuts

5X - 5/16" (8 mm)
2X - 1/4" (6mm)

Square nuts



4X - 3/8"
5X - 5/16"
1X - 1/4"



4 screw eyes R6 for back post



2X eye screws

Round head screw



4X - #12 x 1 1/2"
2X - #14 x 2 1/2"



Tacks for canvas

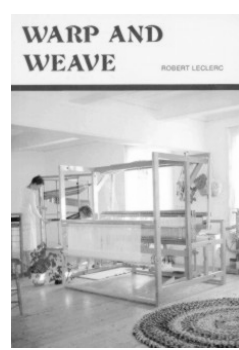

1 book Warp&Weave



2 Loop cord 20" (stabilizing post)

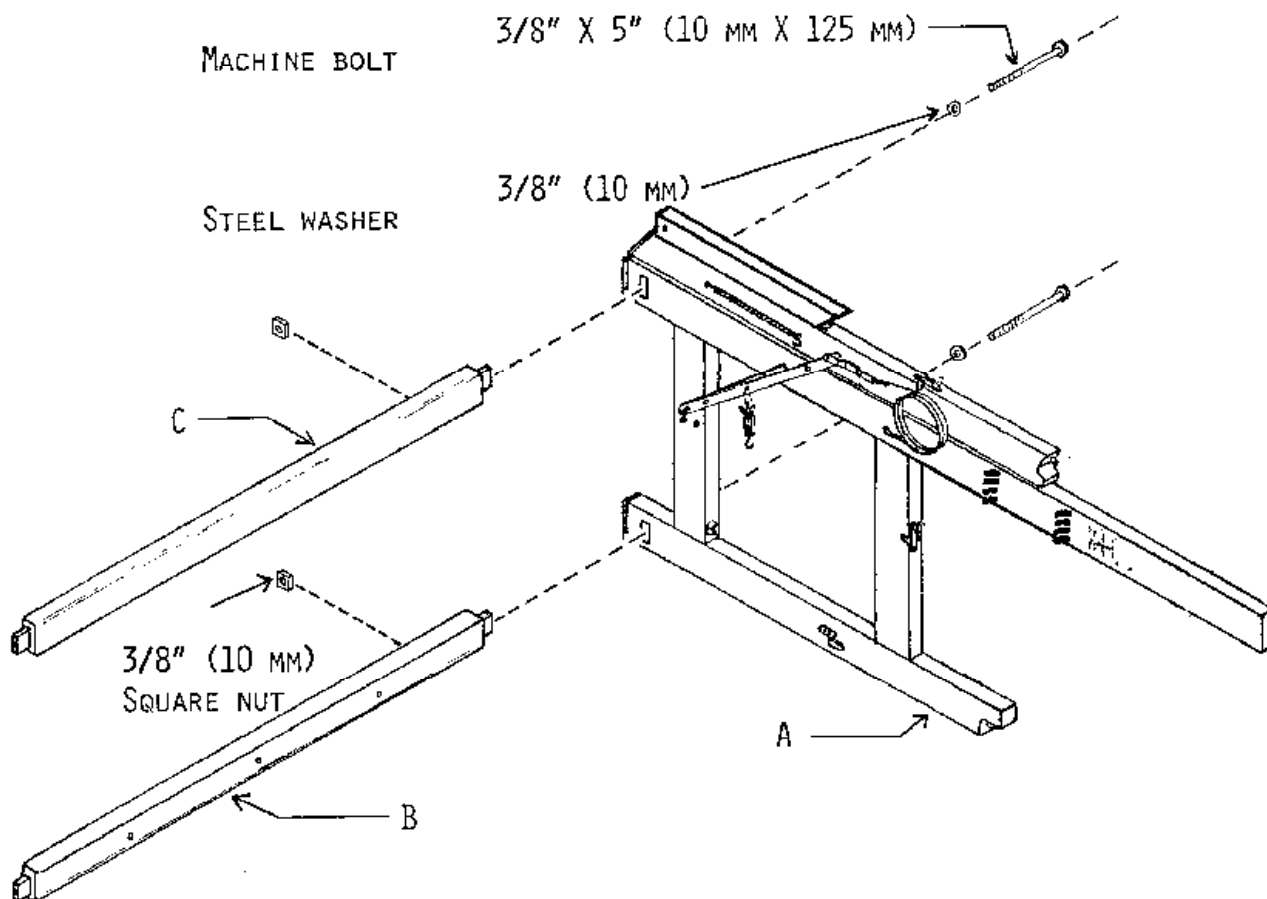

Fig. 1

Place right-hand side A of the loom on its front.

Insert the tenon of lower front cross-member B into the lower front mortise of right-hand side A. (Fig. 1)

NOTE: The lower front cross-member has 3 holes drilled through it.

Using the wrench supplied with the loom, affix cross-member B with a 3/8" X 5" (10 mm X 125 mm) machine bolt, a 3/8" (10 mm) steel washer, and a square nut. (Fig. 1)

Insert a tenon of lower back cross-member C into the lower back mortise of right-hand side A. (Fig. 1)

NOTE: The lower back cross-member C has 2 holes drilled through it.

Affix cross-member C with a 3/8" X 5" (10 mm X 125 mm) machine bolt, a 3/8" (10 mm) steel washer, and a square nut (Fig. 1)

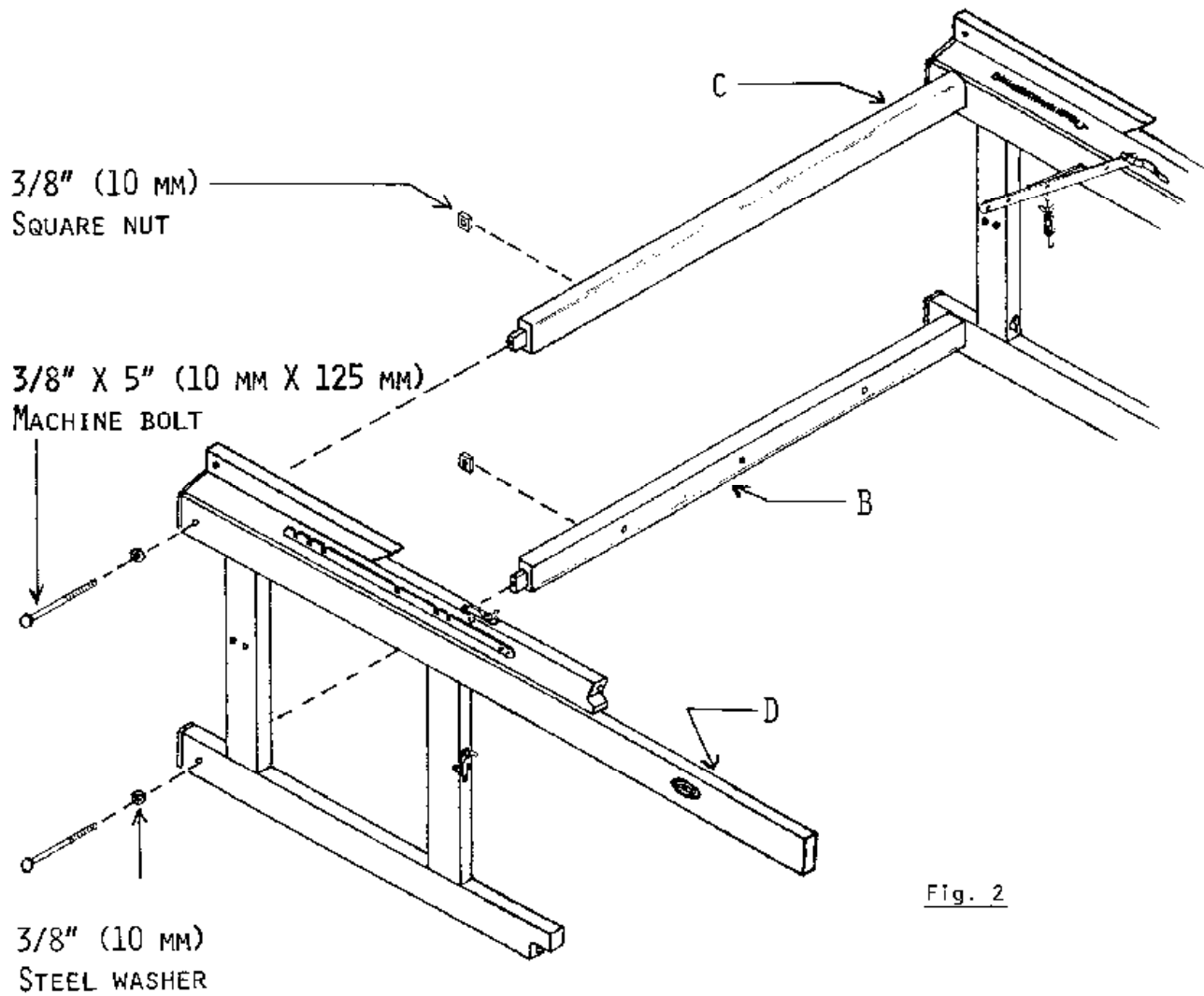

After having placed left-hand side D of the loom on its front, insert the tenons of cross-members B and C into the lower mortises of left-hand side D. (Fig. 2)

Use 3/8" X 5" (10 mm X 125 mm) machine bolts, 3/8" (10 mm) steel washers, and square nuts. (Fig. 2)

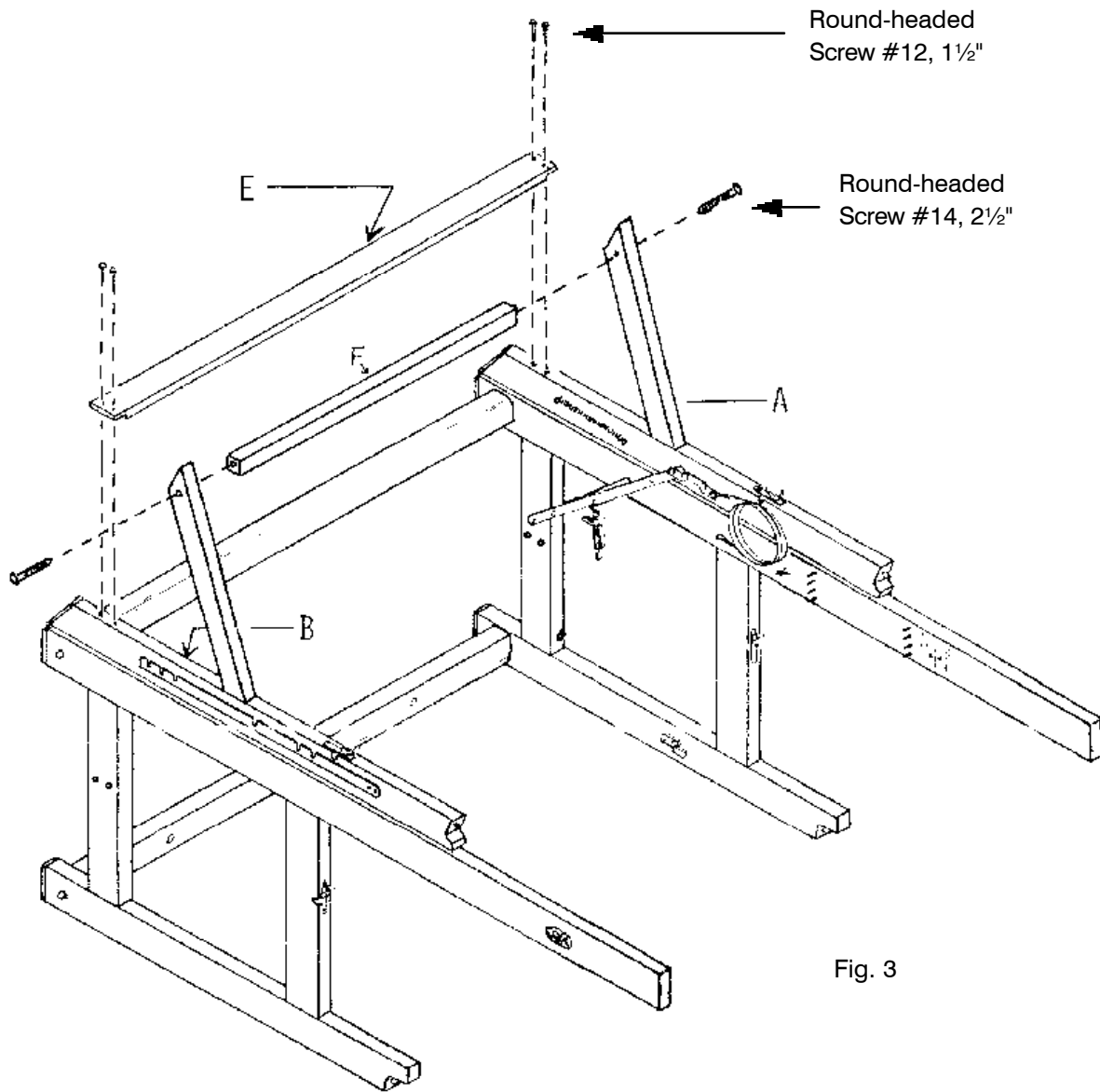

Fig. 3

Using four 1½" (40 mm) round-headed screws No 12, affix back cross-member E to back posts A and B. (Fig. 3)

NOTE:

If cross-member E does not fit between posts A and B, insert it higher between the posts then slide it down. Application of soap to the screws will make their insertion easier.

Using two, 2½" (65 mm) round-headed screws No. 14, affix the cross-member for the stabilizing posts F.

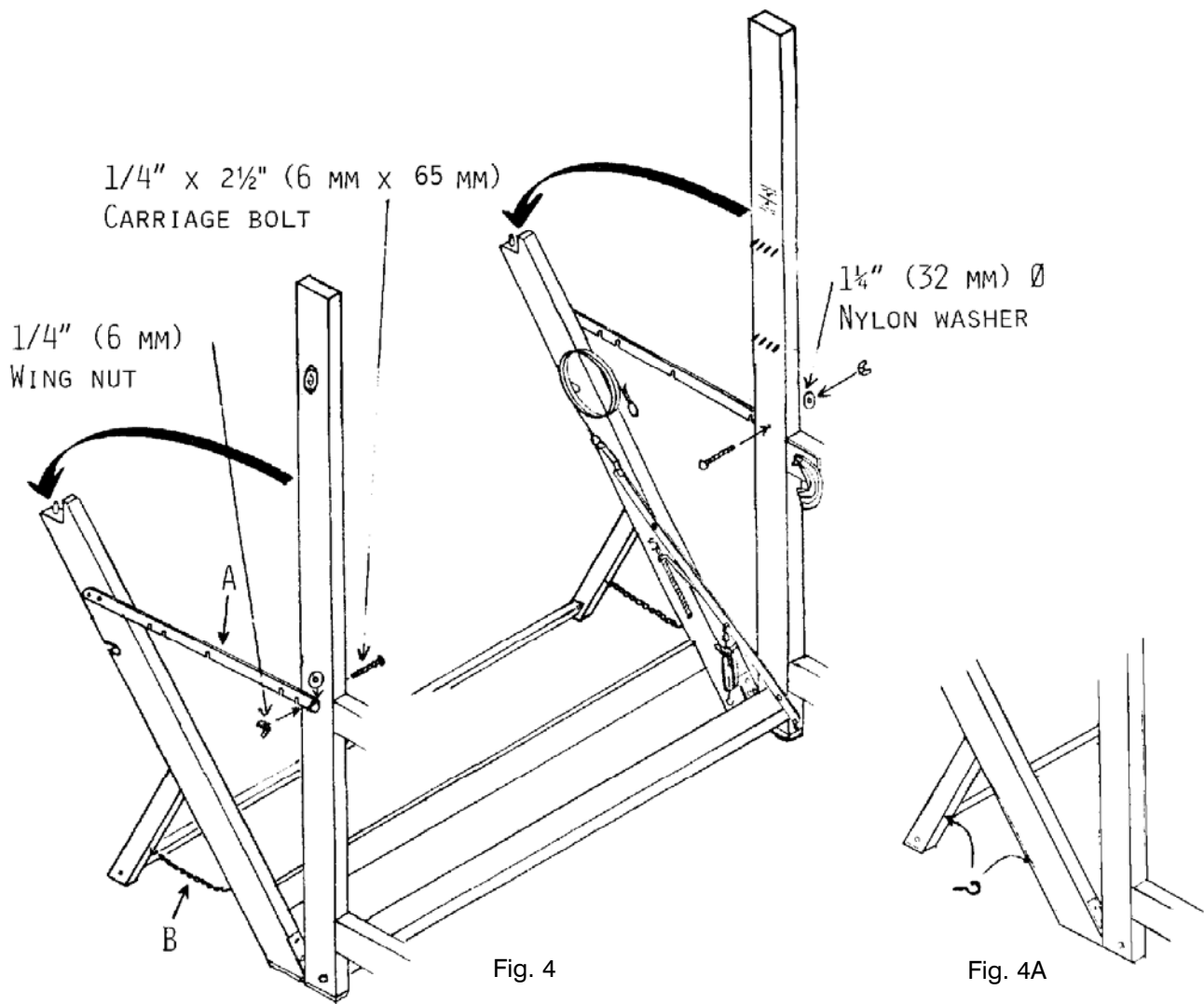

Unfold the back section of the loom and lock it in place with metal hooks A. (Fig. 4)

Insert a 1/4" x 2 1/2" carriage bolt into the holes of the uprights. The nylon washer is already installed in the upright. Fasten the bolt with a 1/4" wing nut.

Be sure that the stabilizing posts are open and flat on the floor. Affix two hooks into the predrilled holes.

(Fig. 4A)

Put loop cord B in place. These cords need to be tight, so they will secure the stabilizing posts. (Fig. 4)

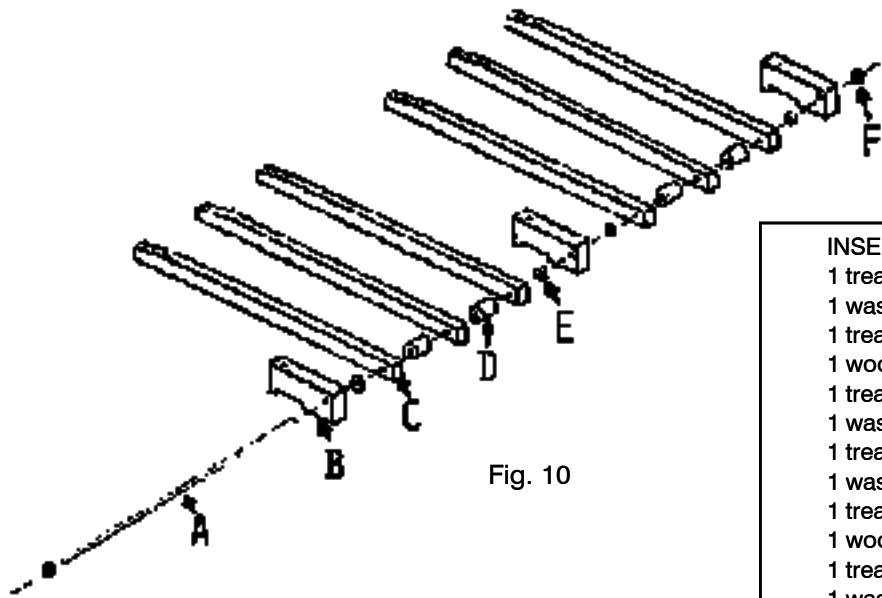

Fig. 10

- INSERT NEXT TO THE PUSH NUT:
- 1 treadle block
 - 1 washer 1/2"
 - 1 treadle
 - 1 wood spacer X2
 - 1 treadle
 - 1 washer 1/2"
 - 1 treadle block
 - 1 washer 1/2"
 - 1 treadle
 - 1 wood spacer X2
 - 1 treadle
 - 1 washer 1/2"
 - 1 treadle block
 - 1 PUSH NUT

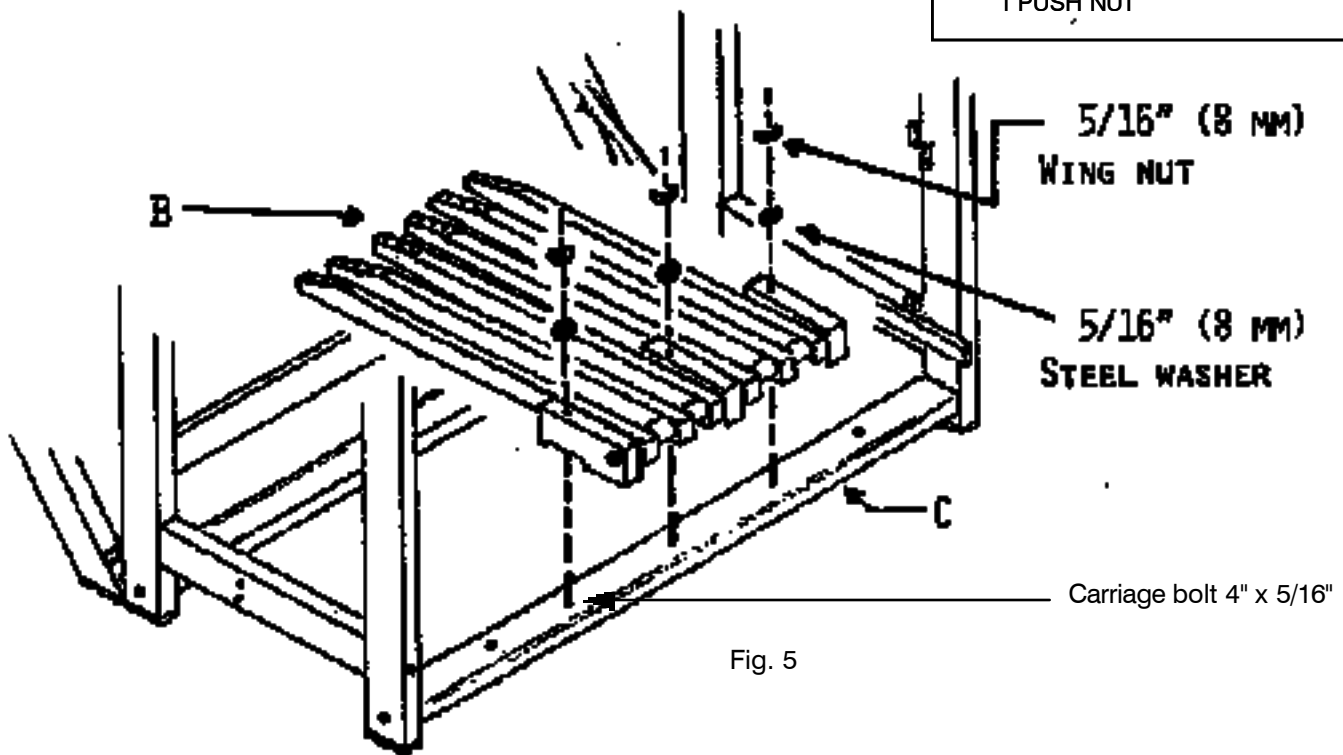

Fig. 5

Assemble the treadle set as illustrated. (Fig. 5)



If you do not want to have the wing nuts on the top of the treadle set, insert the carriage bolts 4" x 5/16" (from the top) into the treadle set supports and the treadle cross-member. Affix them using 3 x 5/16" square nuts and 3 x 5/16" steel washers.

For more information see the Video.

NOTE: Install the second side push nut only after the set is affixed to the loom.

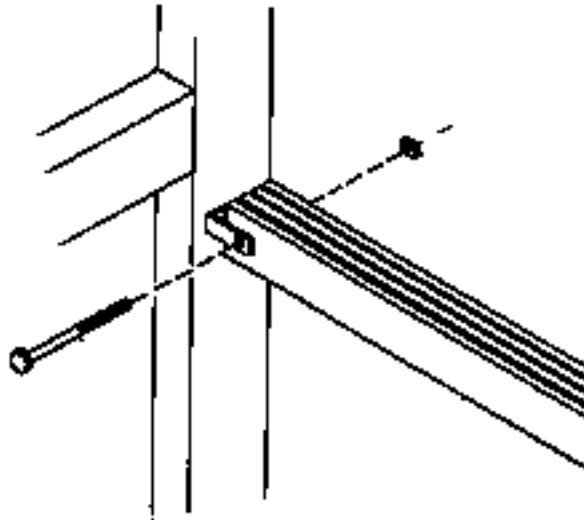
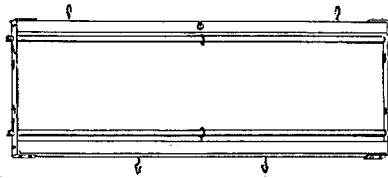

Fig. 6

Using a 1/4" x 3" (6mm x 75mm) machine bolt and a 1/4" square nut, affix the four lams to the lam support of the left-hand side main post. (Fig. 6)

NOTE: The upper side of the lams have hooks.



Install the heddles (see WARP & WEAVE).

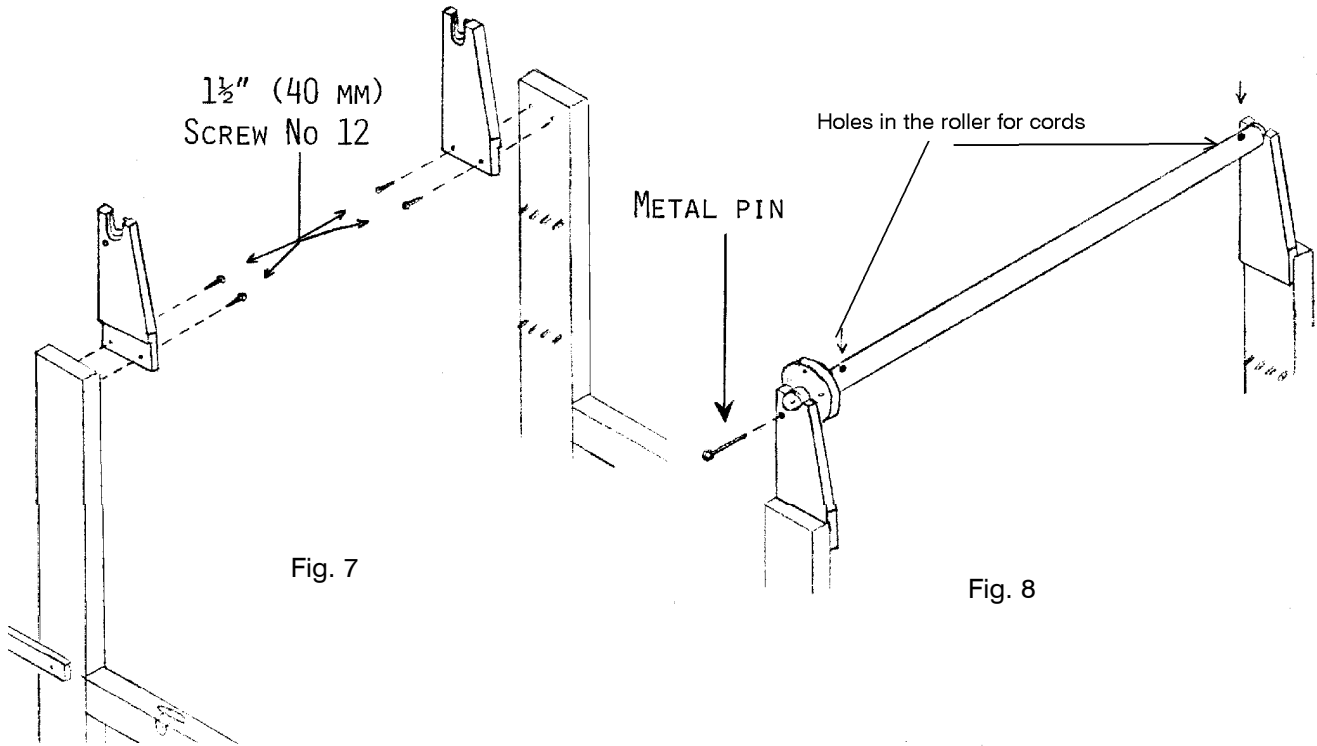

Fig. 7

Fig. 8

Using 1½" round-headed screws No 12, fasten the two roller supports to the center posts (Fig. 7)

Place the shed regulator roller on the supports. The pulley should be on the left hand side of the loom.

Insert the 3" metal pin through the support and one of the hole of the pulley to lock while the holes in the roller for the cords face upwards. Fig. 8

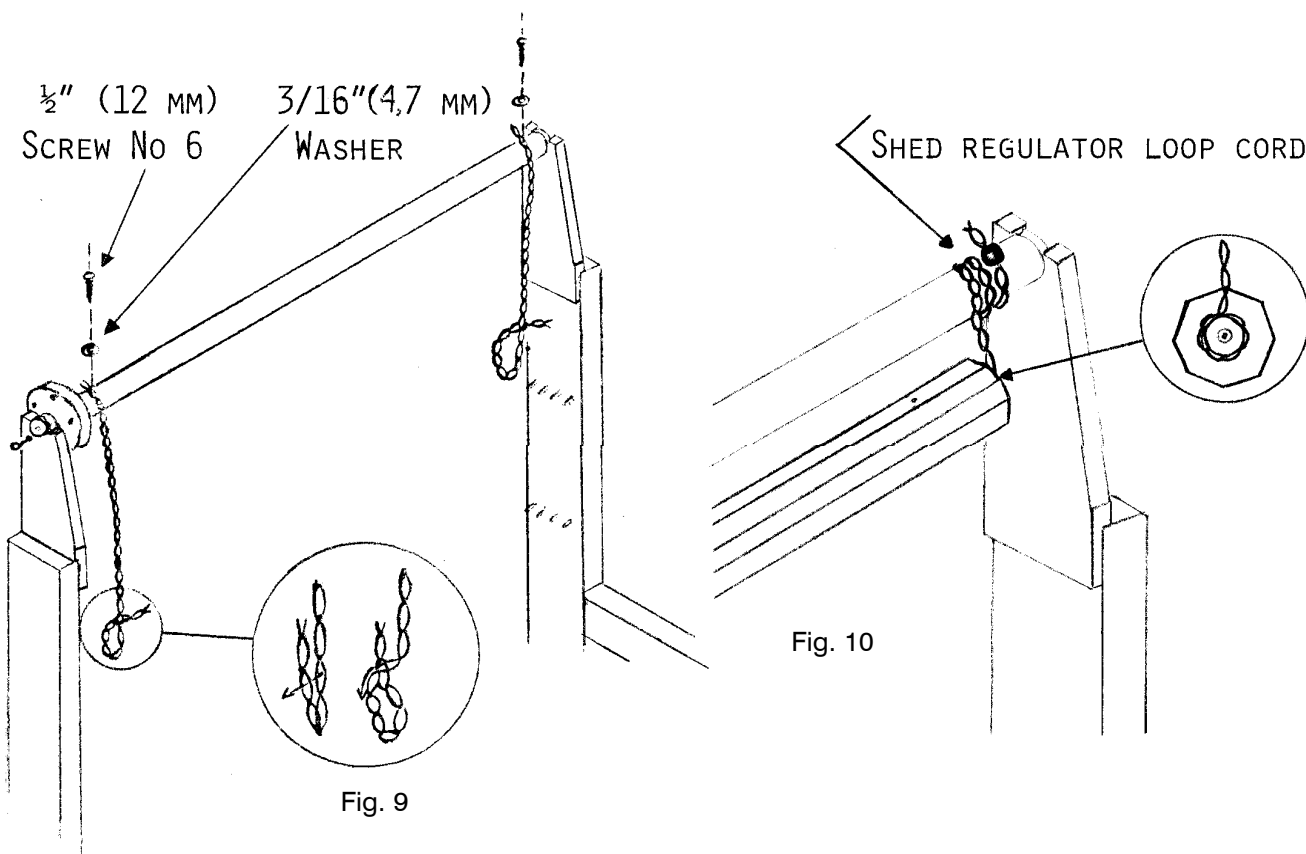

Using a $\frac{1}{2}$ " round-headed screw No. 6 and a $\frac{3}{16}$ " flat washer, fasten one end of each of the two 17" loop cords onto the holes on the top of the shed regulator roller. Fig. 9

Make a large loop in the other end of one cord by folding it 3" from the end and drawing the cord through the second last loop. Fig. 9

Commencing with a downward motion from the front to the back, pass the cord around the shed regulator roller twice. Slip the loop around the pulley on the end of the large octagonal roller. Repeat this process for the other side. Fig. 10

Make sure that the distance between the rollers is the same at each end. If not, adjust the loop.

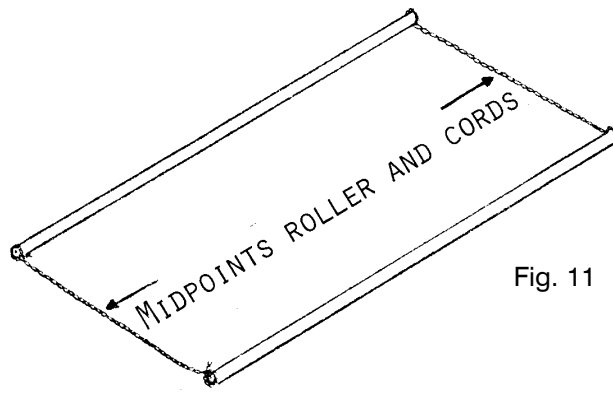

Fig. 11

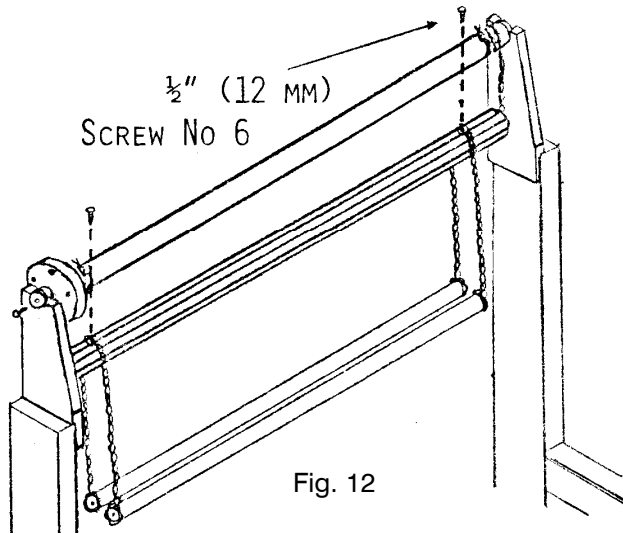

Fig. 12

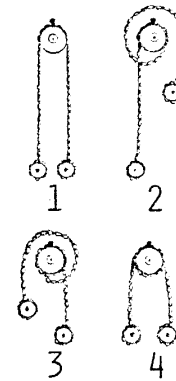

Fig. 13

Fasten the two 30" loop cords to the pulleys of the two small rollers (Fig. 11) by forming a loop at each end of the loop cords as previously described (figure 9)

Make sure that the distance between the rollers, is the same at each end.

Fasten two 1/2" round-headed screws No. 6 into the holes on the upper side of the large octagonal roller. Do not fully tighten the screw but leave a gap of 3/32" to allow for the cord. (Fig. 12)

Locate the loop closest to the midpoint (Fig. 6) on the cords connecting the small rollers and place under the head of the screws in the large octagonal roller (as illustrated in figure 12)

Pass the cords (connecting small rollers) once around the large octagonal roller (as illustrated in figure 13)

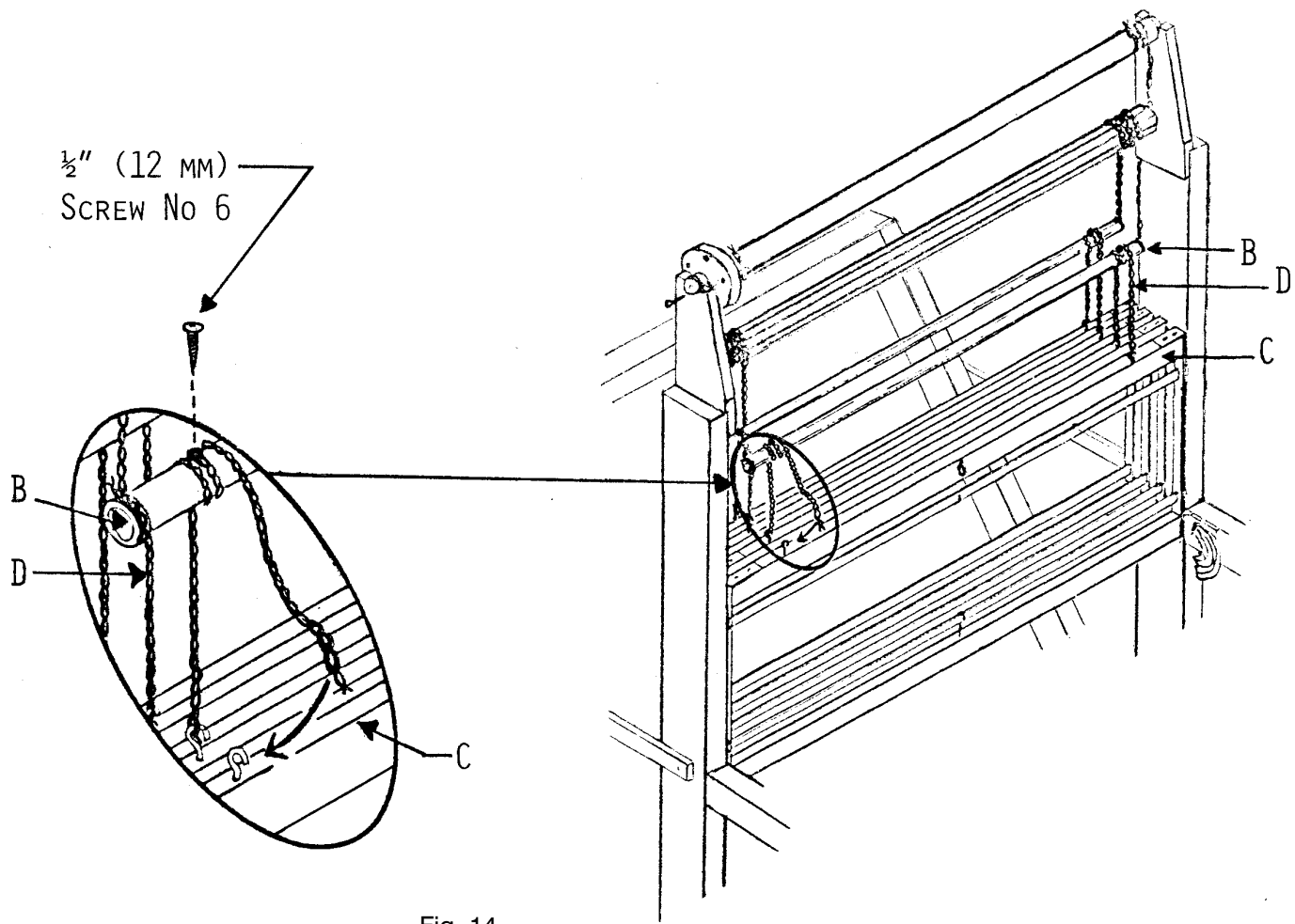

Fig. 14

Fasten four No 6 , $\frac{1}{2}$ " round-headed screws into the holes on the top of the small rollers. Do not fully tighten. (Fig. 14)

Locate the loop nearest the midpoint on each of the four 20" loop cords and place under the head of the screws in the small rollers. (Fig. 14)

Cords D must be passed around the small rollers B once (as illustrated in figure 8). Select the second to last loop at each end of these cords and slip onto the hooks of the harness frames. (Fig. 14)

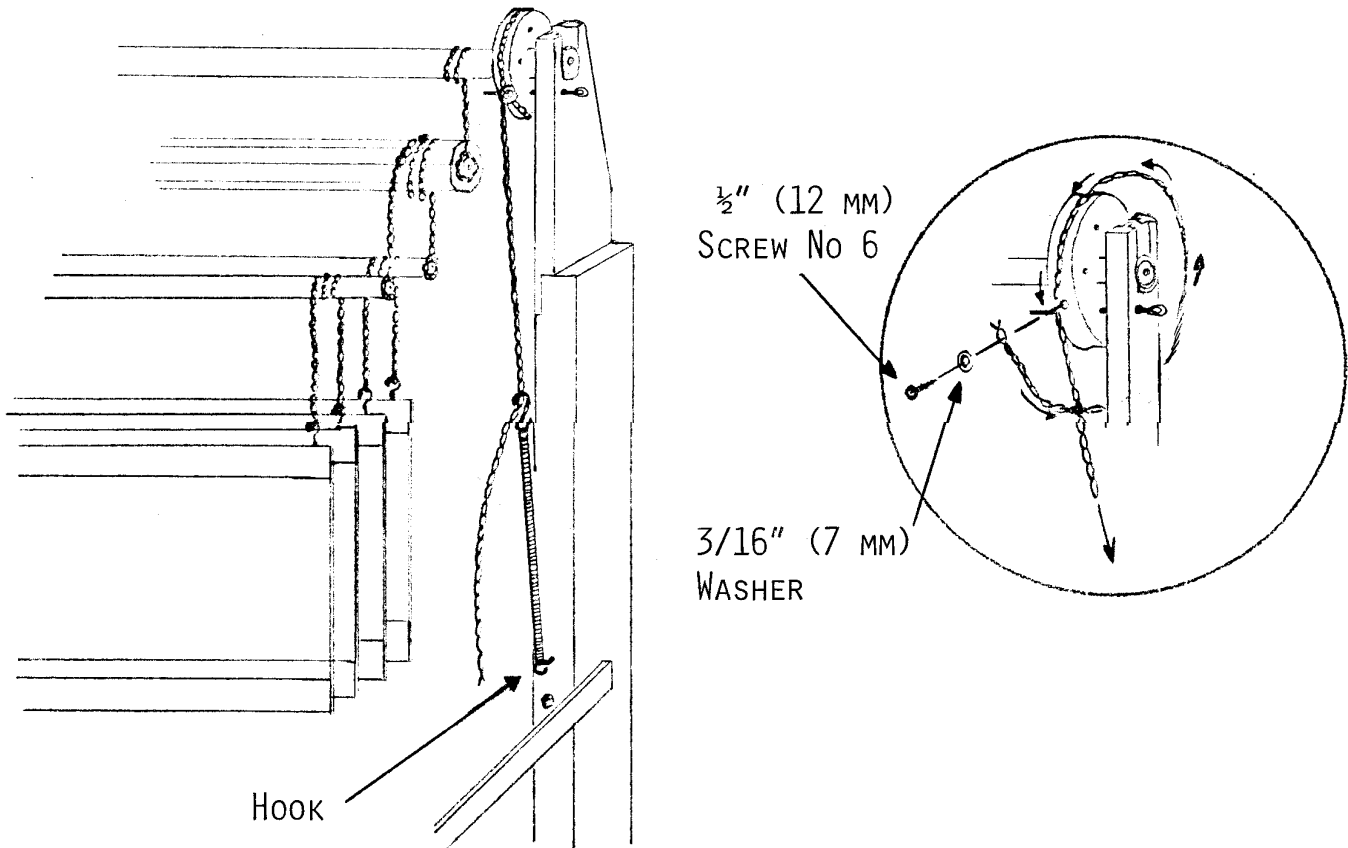

Fig. 15

Stand behind the loom, facing the shed regulator.

Using one 1/2" round-headed screw No 6 and one 3/16" flat washer, attach one end of the 40" loop cord to the pulley of the shed regulator. Pass the cord once around the pulley in a counter-clockwise direction. (Fig. 15)

Slip an "S" hook onto one end of the spring.

Affix a hook into the hole located at the back of the left central post and attach the other end of the spring to it. (Fig. 15)

Attach the "S" hook on the upper end of the spring to the loop cord of the shed regulator, adjusting the height of the harness frames such that the heddles are a little higher than the center of the reed (the loom has to be fully open).
See WARP AND WEAVE.

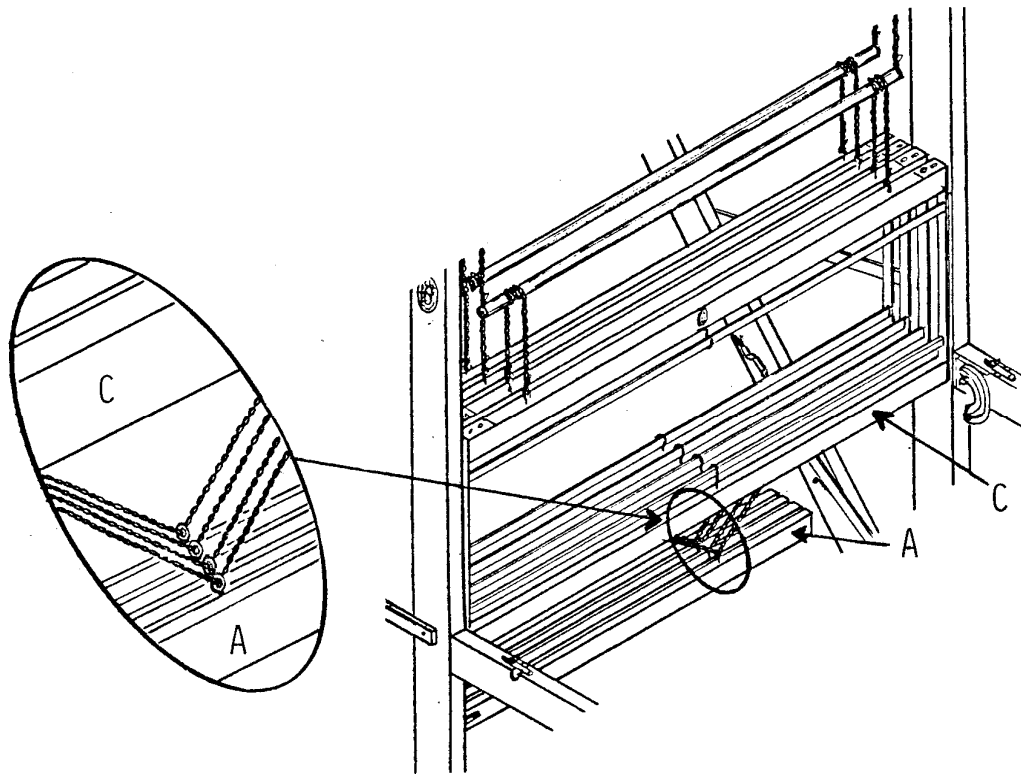

Fig. 16

NOTE: Don't forget to string the heddles prior to attaching the shaft frames to the lams.

Connect shaft frames C to lams A by fastening one end of the 18" loop cord into one of the two hooks under the shaft frame, then pass the cord through the eyelet of the corresponding lam and fasten the other end to the second hook on the same harness frame. (Fig. 16)

Proceed in the same way for the other three harness frames. Be sure that the distance between all harness frames and lams is the same.

Your loom is now adjusted for a counter-balanced weave. If you wish to treadle one harness against three, you must engage the shed regulator by removing the metal pin from the pulley, and readjusting the tension of the spring (by inserting the "S" hook in another loop) to obtain the best shed.

When weaving balance treading, we suggest to lock the shed regulator with the metal pin.

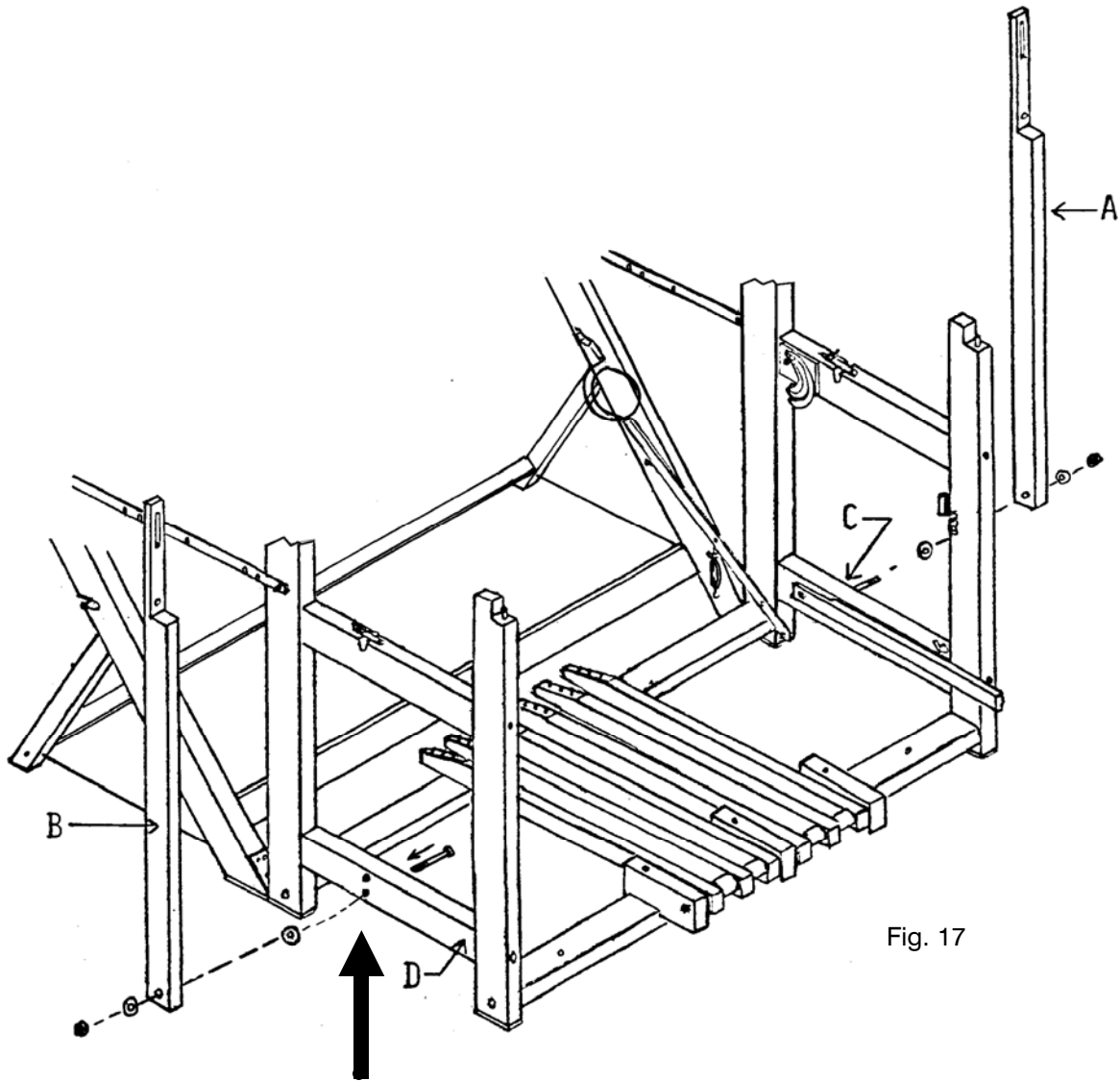

Fig. 17

NOTE: Hammer the carriage bolt inside the hole so it will lock while you will screw the auto lock nuts.

Using 5/16" x 3½" (8 mm x 89 mm) carriage bolts, affix swords A and B to lower front cross-members C and D. Insert the bolt from the inside into the **lower hole** (counter-balanced loom)

Place a 5/16" (8 mm) steel washer between the cross-member and the sword and another on the outside, and secure with a 5/16" (8 mm) nylon auto lock nut.

The grooves on top of the swords must be in front.

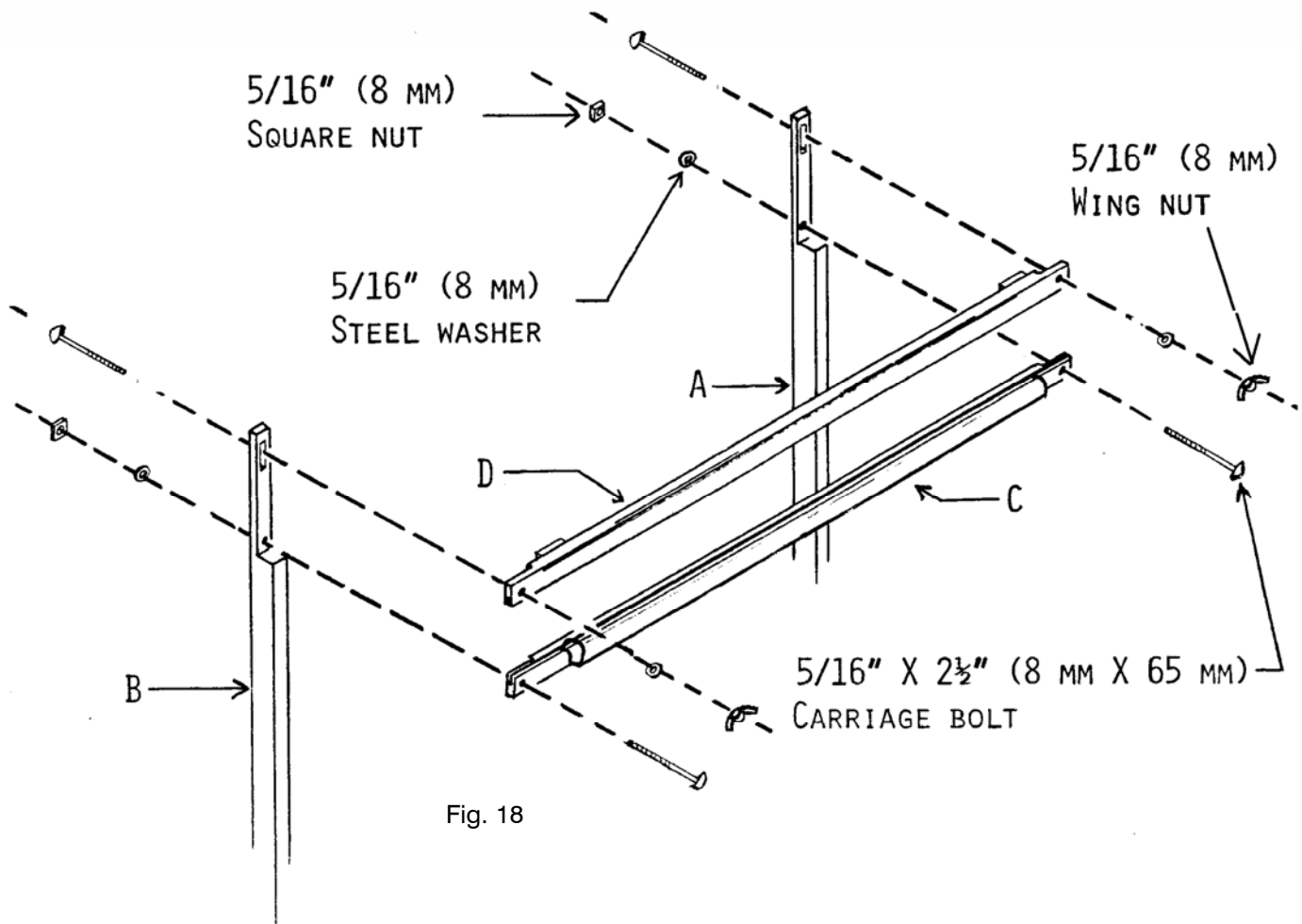

Fig. 18

Using 5/16" x 2½" (8 mm x 65 mm) carriage bolts, 5/16" (8 mm) steel washers, and square nuts, affix batten sley C to the lower holes of swords A and B. (Fig. 18)

NOTE: The batten sley does not have polyvinyl bumpers but it has a shuttle race.

Using 5/16" X 2½" (8 mm X 65 mm) carriage bolts, 5/16" (8 mm) steel washers, and wing nuts, affix batten handtree D to swords A and B. (Fig. 18)

NOTE: The batten handtree has polyvinyl bumpers.

The slots of the batten sley and handtree must face each other.

WARP BEAM INSTALLATION

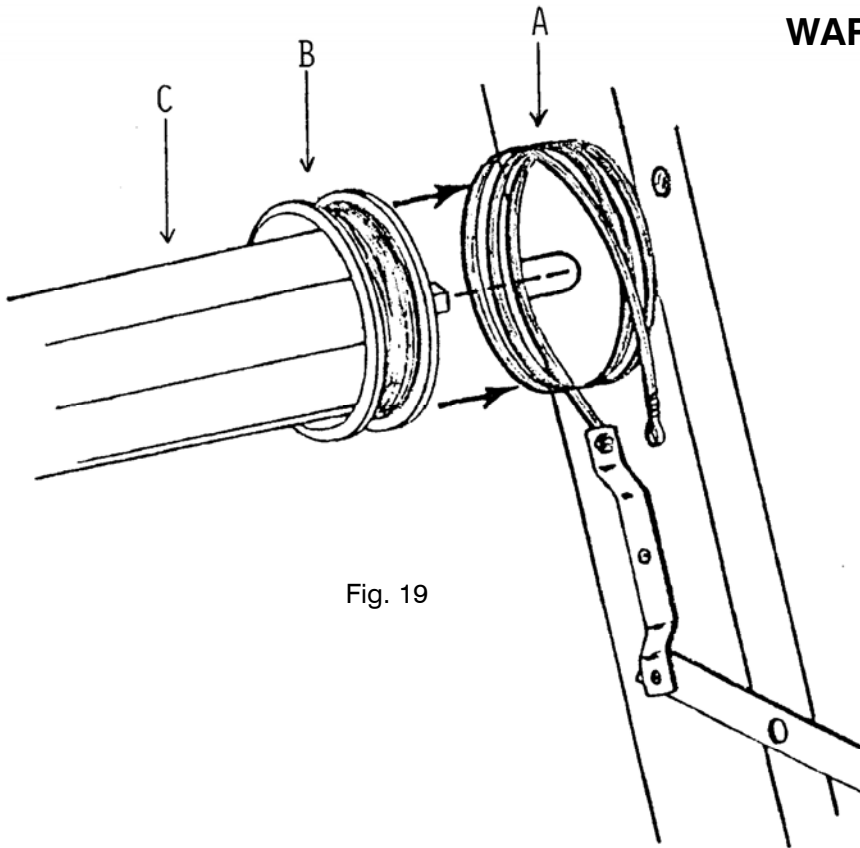

Fig. 19

Hold the circular wire brake shoe A slightly to the rear of the loom, **but do not unroll it.**

Loose tension on the circle by unscrewing the turnbuckle.

Insert the brake drum B into the wire brake shoe A. Then, install the ends of the warp beam C into the grooves of the back posts. (Fig. 19)

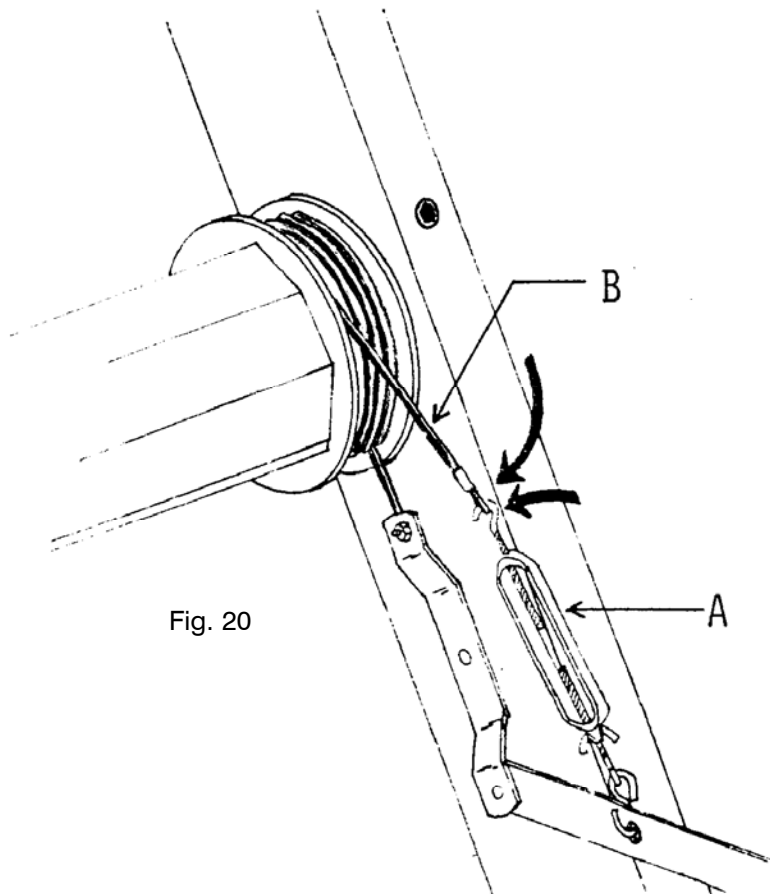

Fig. 20

Hook turnbuckle A to flat wire circle B. (Fig.20)

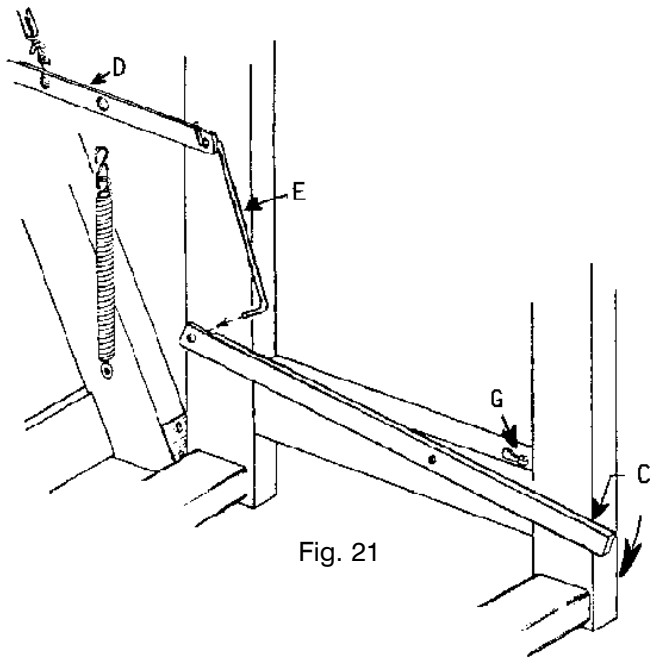

Fig. 21

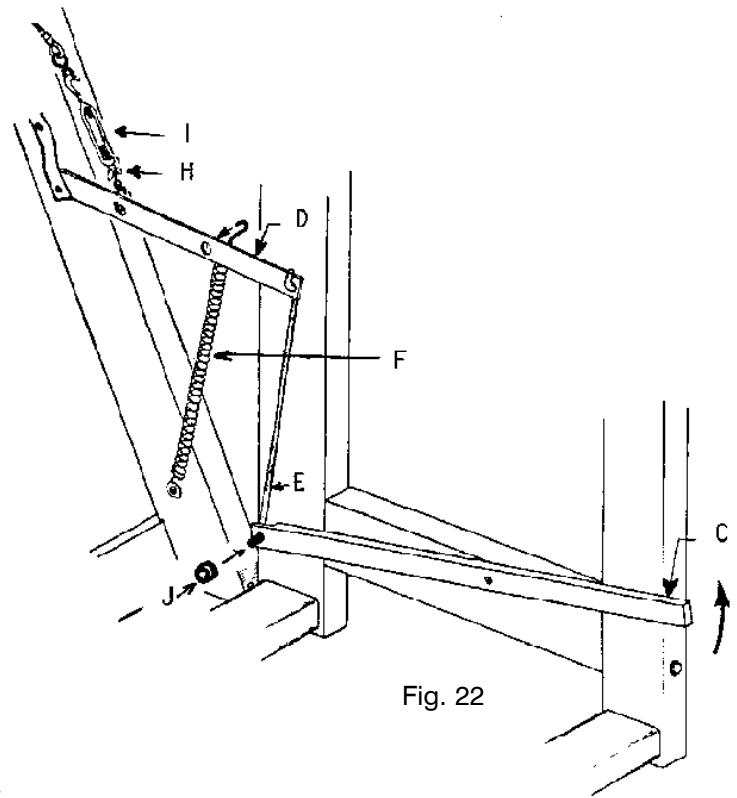

Fig. 22

Using metal rod E, join treadle C to lever D. First insert the double-cornered end of the metal rod into lever D; then insert the other end of the metal rod into treadle C while the treadle is depressed. (Fig. 21)

Raise treadle C as high as possible then hook spring F to lever D. (Fig. 22)

BRAKE ADJUSTMENT:

Release the brake by depressing treadle C and locking it down with the catch G. (Fig. 21) The warp beam should turn freely but the brake circular wire should not be too slack. If the tension is too great, unscrew the wing nut H slightly and then loosen the turnbuckle I. If the tension is too slack, tighten the turnbuckle I slightly and then the wing nut H. (Fig. 22)

You will add a black rubber ring J to the lower end of the rod E, to prevent the rod from slipping out. (Fig. 22)

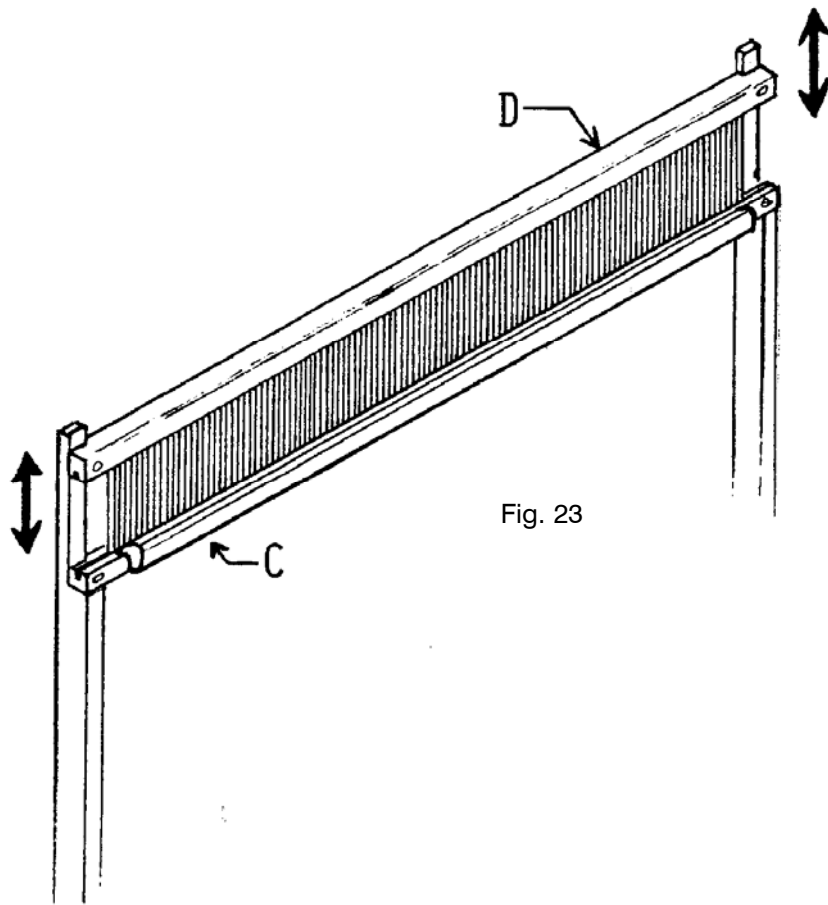

Fig. 23

Place the reed between batten sley C and handtree D. (Fig. 23)

When the wing nuts are loose, the batten handtree can slide vertically in the sword slots. The reed must then be secured between the batten sley and handtree by tightening the wing nuts.

If the batten does not touch the two bumpers equally, loosen the bolts of the batten sley and handtree and exert pressure on the batten centering it in its proper place. Tighten the bolts again.

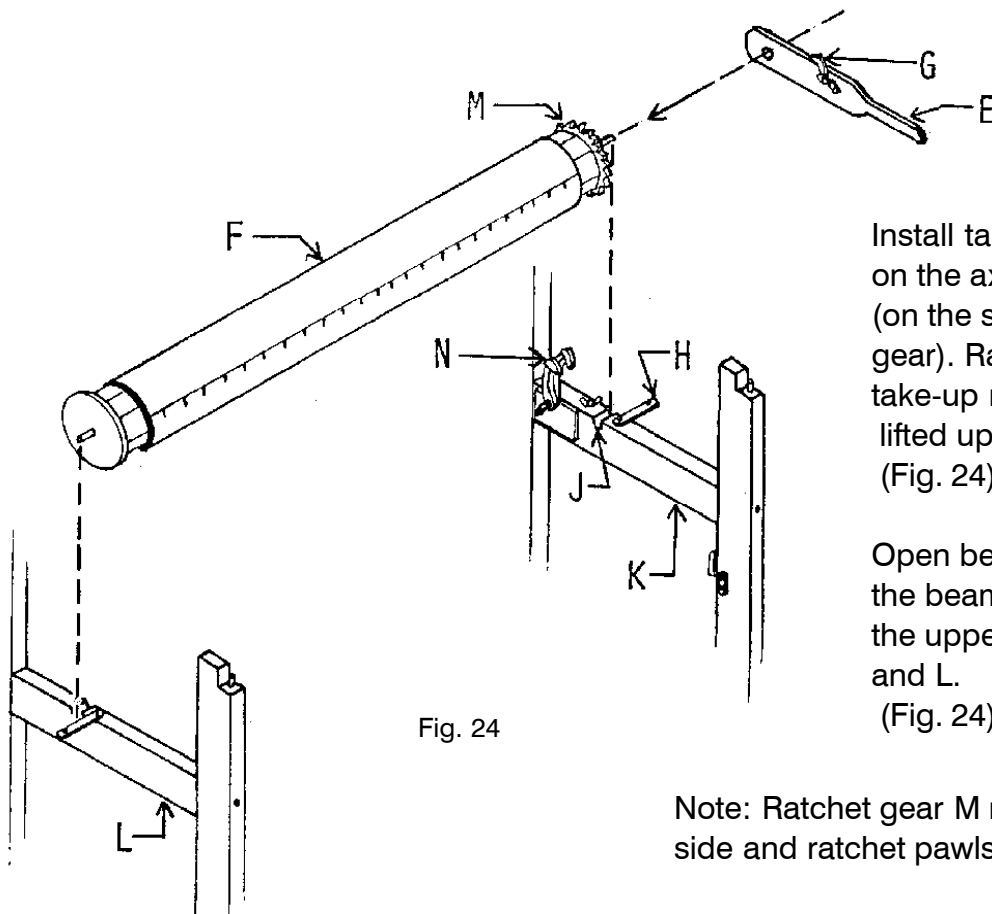

Fig. 24

Install take-up motion handle E on the axle end of cloth beam F (on the same side as the ratchet gear). Ratchet pawl G of the take-up motion handle must be lifted up. (Fig. 24)

Open beam latches H and place the beam ends in the slots J of the upper side cross-members K and L. (Fig. 24)

Note: Ratchet gear M must be on the right-hand side and ratchet pawls N must be lifted up.

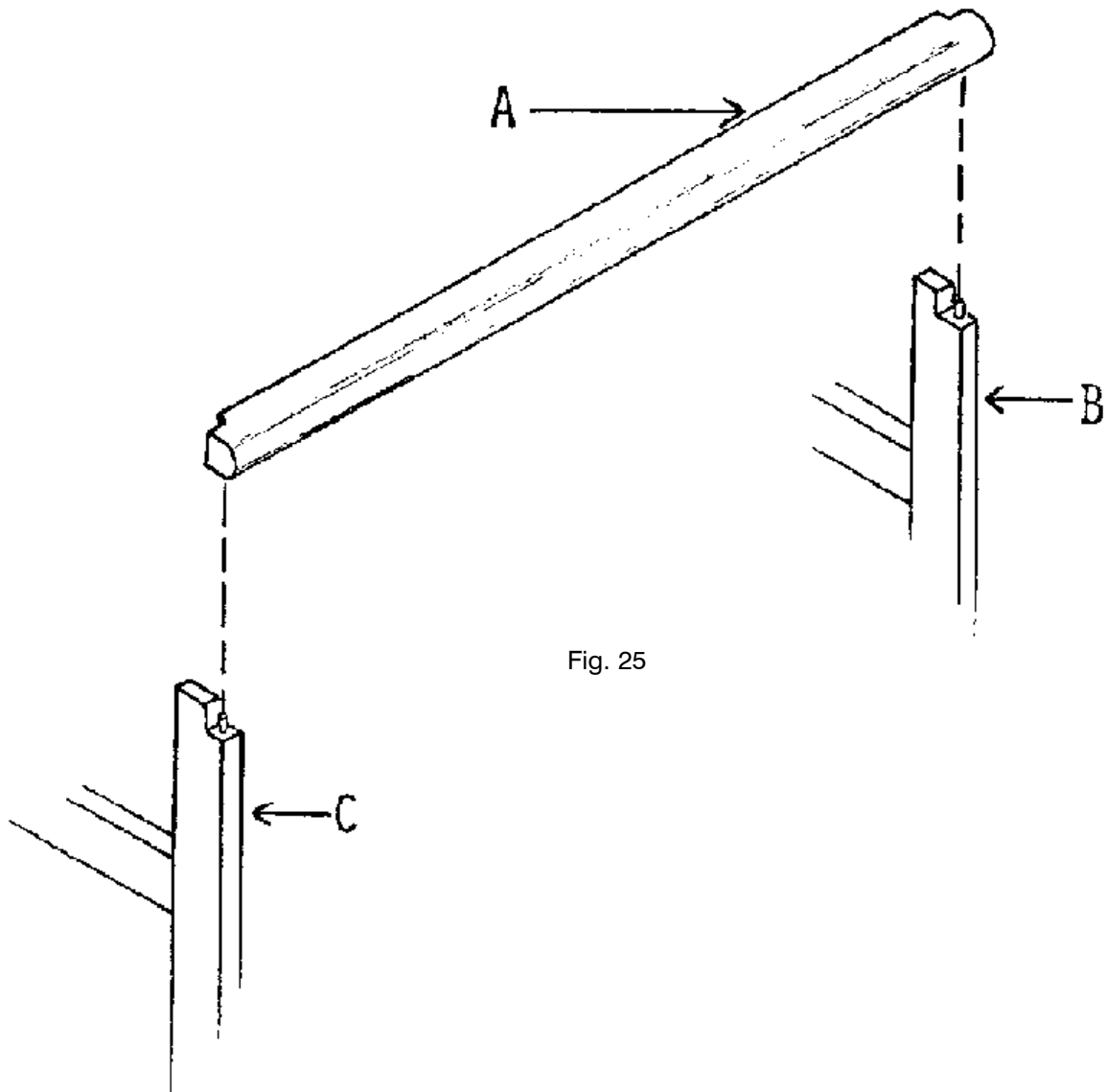

Fig. 25

Affix one of the breast beams A on the top of the front posts B and C. (Fig. 25)

Affix the other breast beam on top of the back posts.

NOTE: To avoid splitting the front posts, slightly insert the breast beam onto the metal pin. Be sure that it is in the right position before inserting it completely.

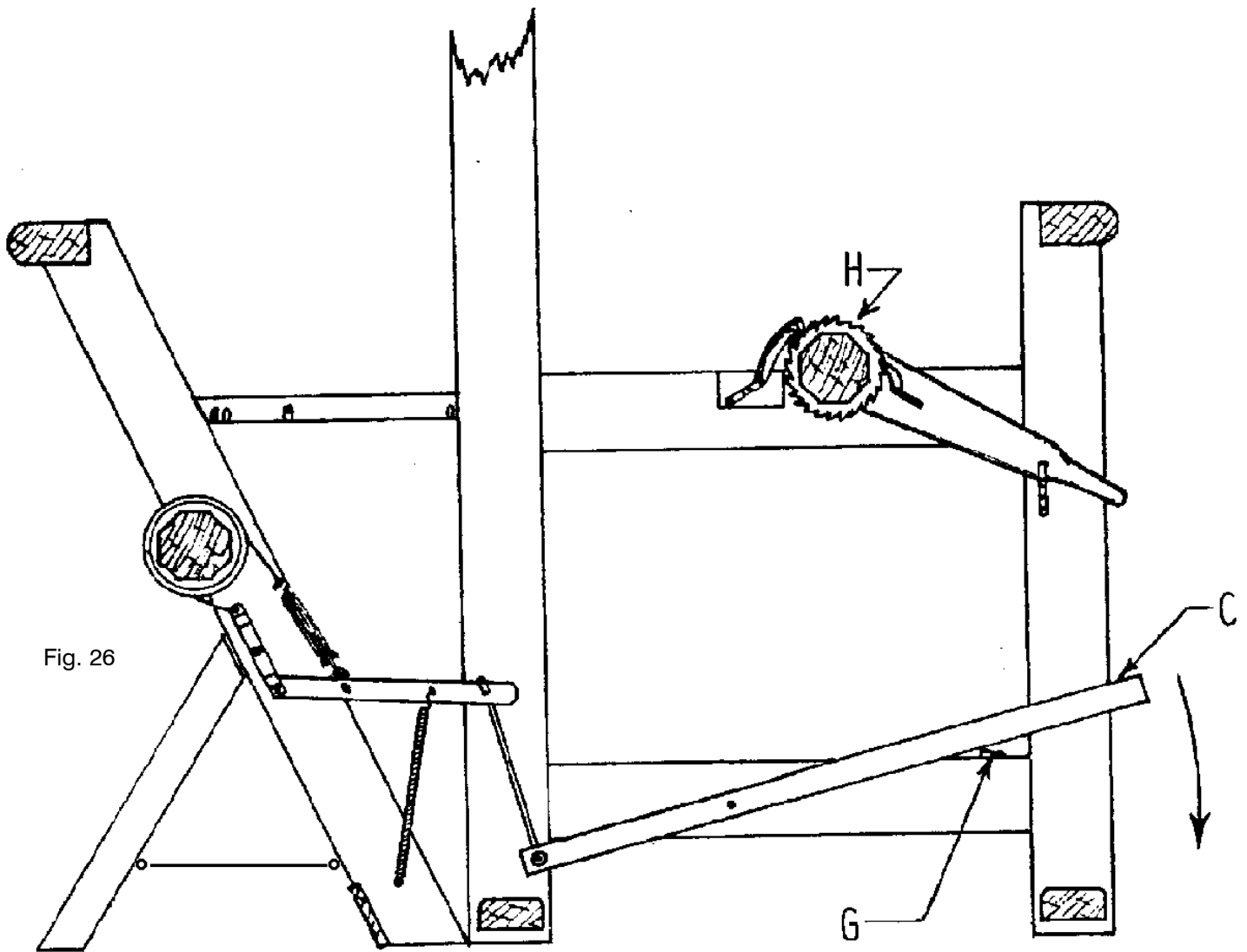

Fig. 26

FOLDING LOOM AND BEAMING:

Release the brake by depressing treadle C and by locking it down with catch G. Release the 4 metal hooks and fold the back of the loom.

WEAVING:

To advance the warp, depress brake treadle C and turn cloth beam H at the same time. Then release brake treadle C and advance the cloth beam until the next notch in the ratchet gear is reached. If this is too much tension, gently depress the brake treadle until the desired tension is obtained. (Fig. 26)

MORE INFORMATION:

See "WARP AND WEAVE", page 87.

FIRST TREADLE TIE-UP

Select any treadle and tie the Lams to the Treadles using the 9" cords supplied with the loom. Take the heddle hook to help make passing the cord through each hole of the lam easier.

Fig. 27

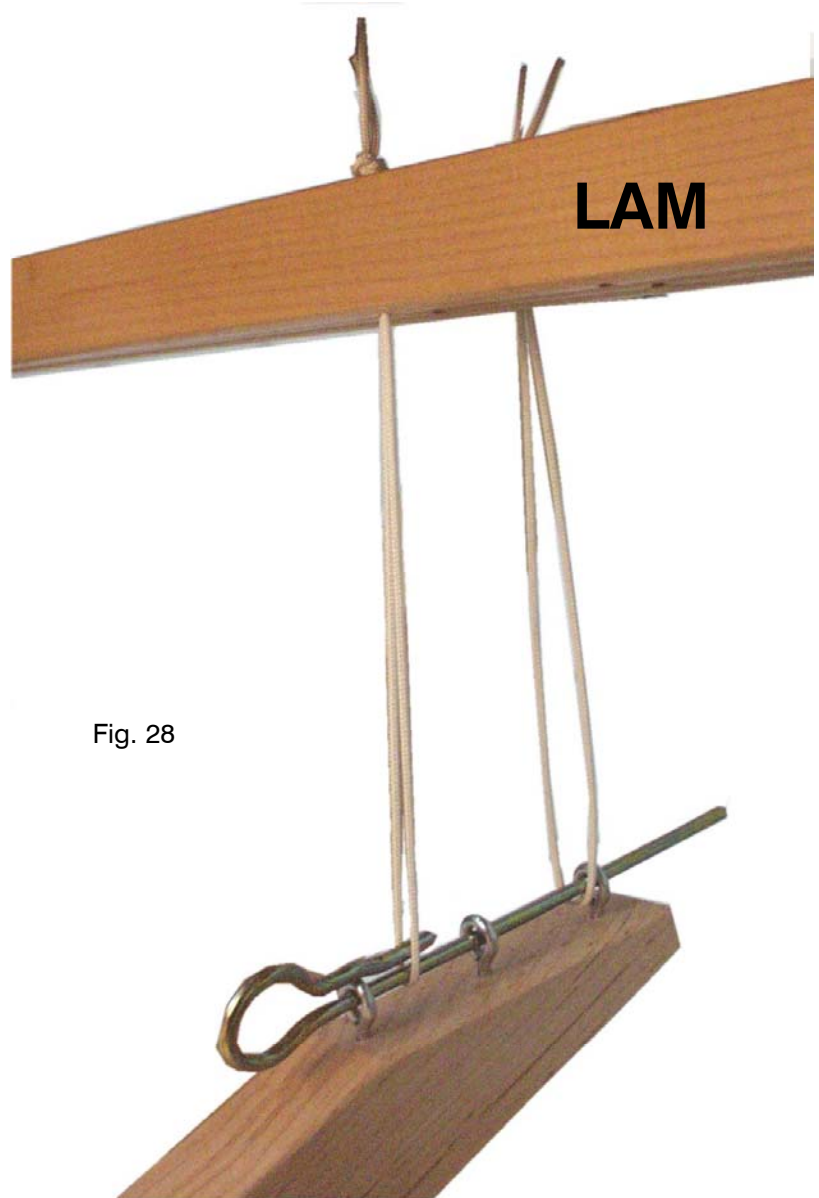
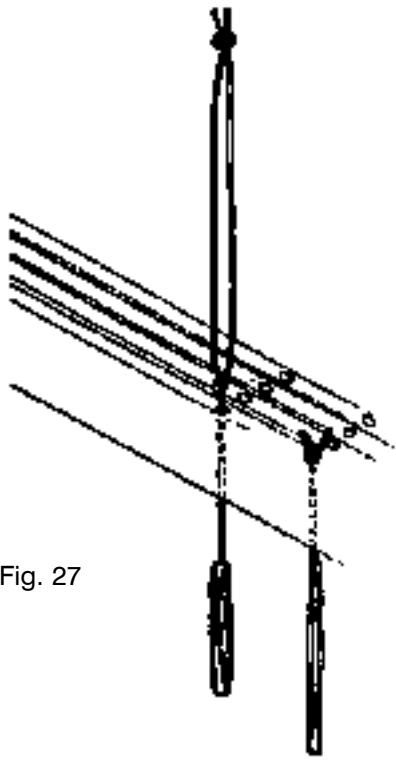

Fig. 28

Slide the Treadle Hook through the Screw Eyes and Cord Loops. (Fig. 28)

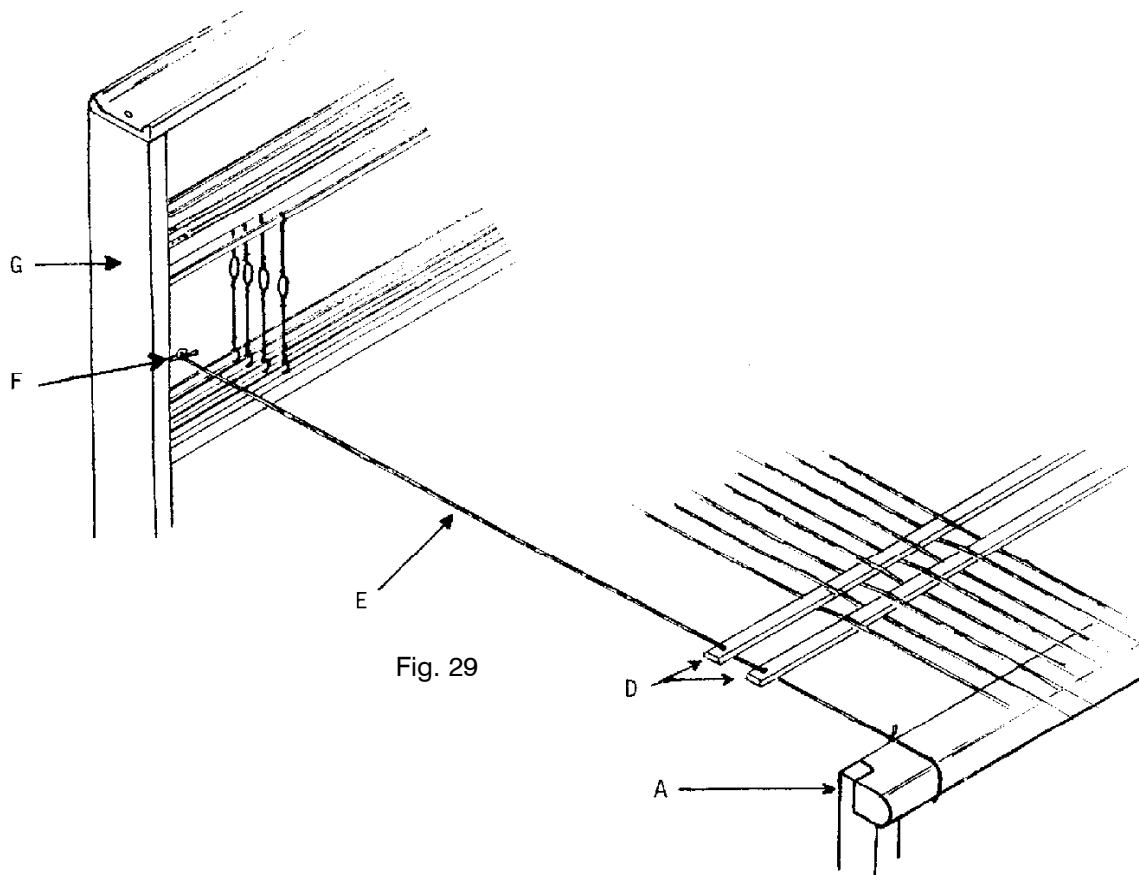

Fig. 29

Affix screw eyes F to the holes inside middle posts G. Pass a string C through the holes at each side of the lease sticks D and tie them to the screw eyes and to the thread beam A. The lease sticks will be held at the right height and distance for easy threading. (Fig. 29)

If the loom is equipped with a sectional warp beam, affix the rake-like pieces (following the instructions supplied with the sectional warp beam) and do the following instructions on the cloth beam only.

If the loom is not equipped with a sectional warp beam, affix the apron to the warp beam with tacks and do the following procedures on the warp and cloth beams.

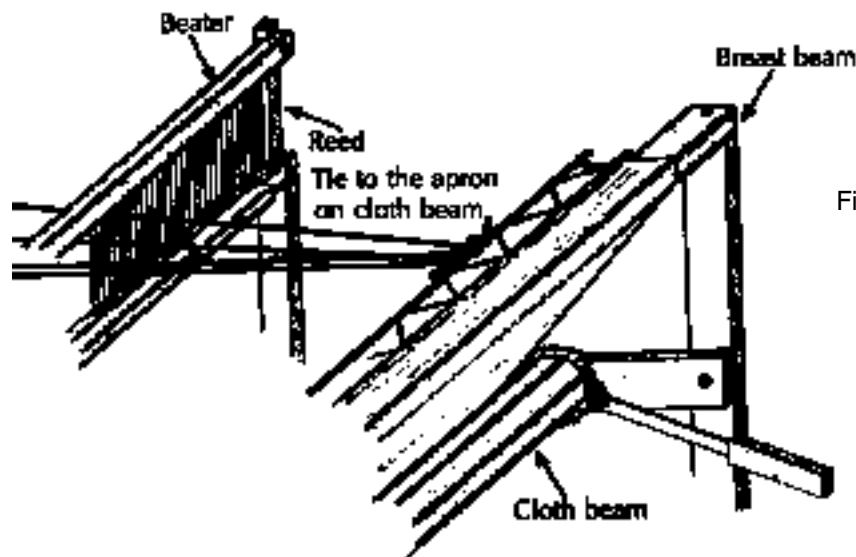

Fig. 30

Insert a warp rod into the apron border.

For 27", 36" and 45" loom
(70cm, 90cm and 115cm)

For 60" loom
(150cm)

Cut the 5 yard (4.5m) cord in half.
Use one half of the cord to lace the
apron warp rod to a second warp rod.
This second warp rod will be used to
attach warp threads.

Use a 5 yard (4.5m) cord to lace the
apron warp rod to a second warp rod.
This second warp rod will be used to
attach warp threads.

For more information see the book "Warp & Weave" supplied with the loom.

**We at Leclerc encourage Weaver feedback on this and all
our products. Please
send your comments to Leclerc Loom Co.**

HAPPY WEAVING